

Copyright© 2001 by Big Bike Parts, Inc. No part of this instruction sheet may be reproduced without the written permission of Big Bike Parts, Inc.

RECEIVER HITCH PART NO. 2-437

FOR HONDA GOLD WING GL1500/6 MODELS

Revised 10/16/09

ITEMS REQUIRED: 4MM ALLEN HEAD WRENCH
FOR 1998 MODELS:

7/16" WRENCH, 9/16" WRENCH
8MM WRENCH

CRESCENT WRENCH
12MM WRENCH, HACKSAW

MOUNTING HARDWARE INCLUDED:

AA (2) 1" THREE PIECE CLAMP
BB (2) U-BOLTS
CC (1) RECEIVER HITCH FRAME ASSEMBLY
I (2) SADDLE U-BOLTS
3D (8) 1/4" FLAT WASHERS

3E (8) 1/4" -20 NYLOC HEX NUTS
3F (2) 3/8" -16 X 1.25" LONG BOLTS
3G (4) 3/8" FLAT WASHERS
3H (2) 3/8" -20 NYLOC HEX NUTS

3J (1) 1 7/8" BALL
3K (1) RECEIVER TUBE
3L (1) HITCH PIN
3M (1) HAIR PIN

INSTALLATION:

1. PLACE YOUR BIKE ON ITS CENTER STAND.

NOTE 1A: FOR 1998 -2000 MODELS MUST SWING MUFFLER OUT OF THE WAY.

- a) USING AN 8MM WRENCH, REMOVE THE TWO COVER BOLTS (1A) FROM THE LEFT LOWER SIDE COVER (1B). TAKE OFF COVER BY DISENGAGING THE THREE RUBBER TABS FROM THE PASSENGER FLOORBOARD COVER (1C).
 - b) USING A 12MM WRENCH, LOOSEN (DO NOT REMOVE) THE TWO LEFT SIDE MUFFLER CLAMP BOLTS (2A).
 - c) USING TWO 12MM WRENCHES, LOOSEN THE LEFT SIDE BRACKET BOLT, REMOVE THE WASHER AND NUT (2B) LEAVING THE BOLT IN PLACE. SWING THE MUFFLER DOWN OUT OF THE WAY.
 - d) REPEAT STEPS A THROUGH C FOR THE RIGHT SIDE.
2. FASTEN THE 1" THREE PIECE CLAMPS (AA) TO THE BOTTOM OF THE LEFT AND RIGHT SADDLEBAG GUARDS WITH THE BOLT TABS FACING TO THE REAR OF THE BIKE. LEAVE THE CLAMPS LOOSE SO THEY CAN ROTATE ON THE SADDLEBAG GUARDS.
 3. PLACE THE TWO SADDLE U-BOLTS (I) ON THE REAR PORTION OF THE SADDLEBAG TUBING FRAME.
 4. INSTALL THE RECEIVER HITCH FRAME ASSEMBLY (CC) TO THE 1" THREE PIECE CLAMPS (AA) USING 3/8" -16 X 1.25" LONG BOLTS (3F) WITH 3/8" FLAT WASHERS (3G). SECURE WITH 3/8" -16 NYLOC HEX NUTS (3H) AND 3/8" FLAT WASHER (3G). **LEAVE LOOSE UNTIL ALL FITTINGS ARE IN PLACE.**
 5. INSTALL THE SADDLE U-BOLTS (I) TO THE RECEIVER HITCH FRAME ASSEMBLY (CC) AS SHOWN IN FIGURE 3. USING THE 1/4" -20 NYLOC HEX NUTS (3E) AND FLAT WASHERS (3D). **LEAVE LOOSE UNTIL ALL FITTINGS ARE IN PLACE.**
 6. INSTALL THE OTHER TWO U-BOLTS (BB) AS SHOWN IN FIGURE 3. USING 1/4" -20 NYLOC HEX NUTS (3E) AND 1/4" FLAT WASHERS (3D). **LEAVE LOOSE UNTIL ALL FITTINGS ARE IN PLACE.**

NOTE: MAKE SURE HITCH IS CENTERED ON BIKE BEFORE TIGHTENING BOLTS.

7. USING 7/16" WRENCH TIGHTEN 1/4" -20 NYLOC HEX NUTS (3E) ON ALL U-BOLTS.
8. USING 4MM ALLEN WRENCH TIGHTEN SCREWS ON THE 1" THREE PIECE CLAMP (AA).
9. USING 9/16" WRENCH AND SOCKET, TIGHTEN 3/8" X 1.25" LONG BOLTS (3F) AND 3/8"-20 NYLOC HEX NUTS (3H) ON THE THREE PIECE CLAMPS (AA).

NOTE 2B: FOR 1998-2000 MODELS: REINSTALL THE L/R MUFFLERS AND LOWER SIDE COVERS BY REVERSING NOTE 1A.

10. USING CRESCENT WRENCH FASTEN THE 1 7/8" BALL (3J) TO THE RECEIVER TUBE (3K) AND SECURELY TIGHTEN.
11. SLIDE THE RECEIVER TUBE (3K) INTO THE HITCH, PLACING THE HITCH PIN (3L) THROUGH BOTH, SECURING WITH THE HAIR PIN (3M).

NOTE: YOUR RECEIVER HITCH COMES WITH TWO MOUNTING HOLES ALLOWING YOU TO INSTALL A MUDFLAP BEHIND THE RECEIVER TUBE PLATE. YOUR MUDFLAP MAY HAVE TO BE MODIFIED TO FIT BETWEEN THE RECEIVER TUBE PLATE, USE YOUR EXISTING MUDFLAP HARDWARE.

NOTE: THE EXTRA 3/8" BOLT AND 3/8" HEX NUT ARE FOR THE ANTI-CHATTER. PUT THE NUT ON THE BOLT AND SCREW IT INTO THE NUT ON BOTTOM OF RECEIVER.

CAUTION: WE MAKE EVERY EFFORT TO ASSURE A FIRM FIT BETWEEN THE RECEIVER BALL MOUNT AND THE RECEIVER TUBE FRAME AND MOST TRAILERS WILL NOT BE AFFECTED BY A SMALL AMOUNT OF PLAY. SOME TRAILERS MAY BE NEGATIVELY AFFECTED BY RECEIVER PLAY AND MAY NEED SOME SPECIAL ATTENTION TO SNUG UP THE RECEIVER BALL MOUNT.

CAUTION: FOR USE IN CONJUNCTION WITH PROFESSIONALLY MANUFACTURED MOTORCYCLE TRAILERS. DO NOT EXCEED THE TOTAL RECOMMENDED TRAILER LOADS OF YOUR MOTORCYCLE OR MOTORCYCLE TRAILER MANUFACTURER.

SEE REVERSE SIDE FOR ILLUSTRATIONS

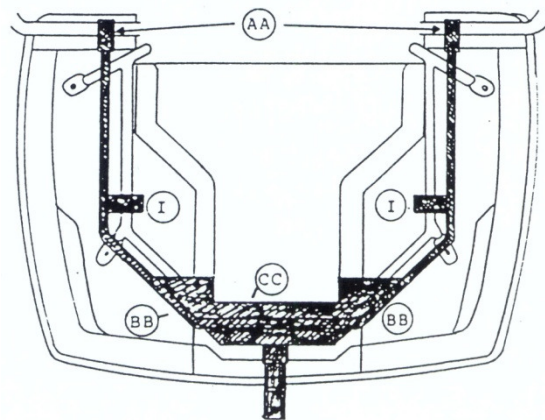
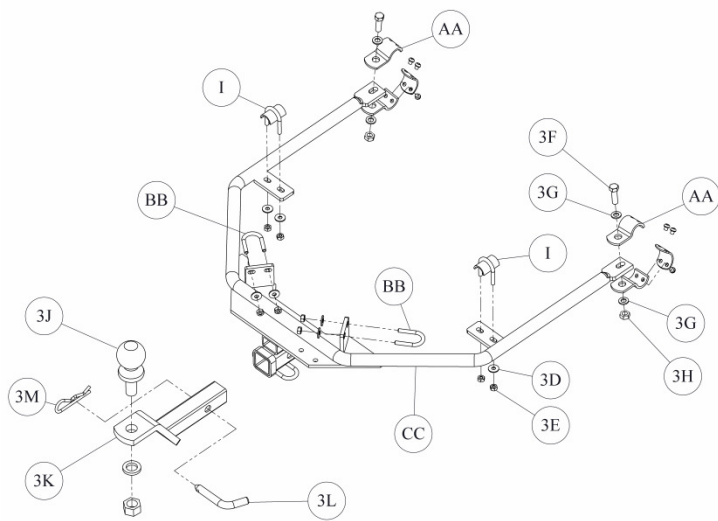
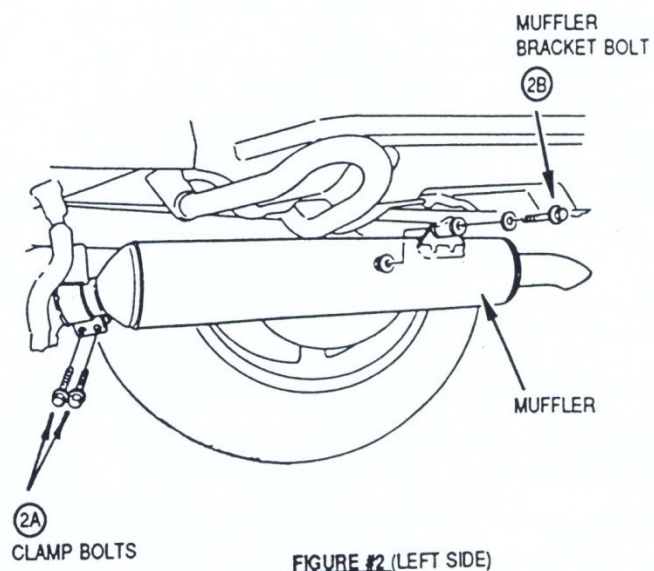
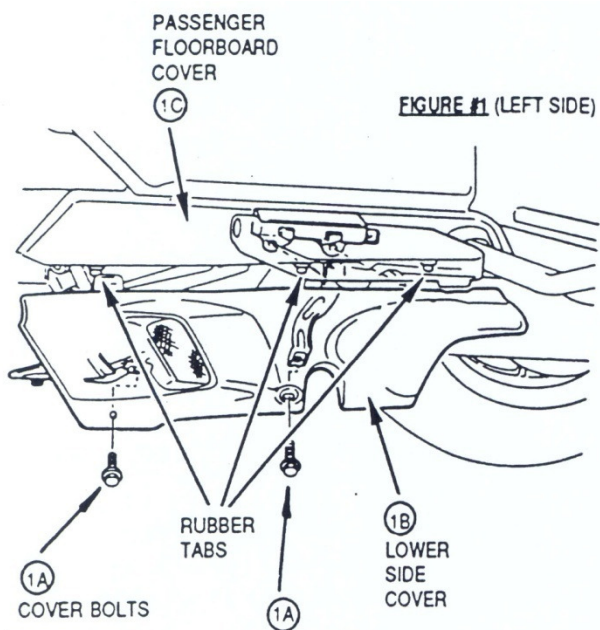

Figure #3