



DRYFORCE™ QUICK RELEASE WATERPROOF COOLER FOR H-D® LUGGAGE RACK

WARNING This indication alerts you to the fact that ignoring the contents described herein can result in potential serious injury or death if not followed.

CAUTION This indication alerts you to the fact that ignoring the contents described herein can or will result in material damage and/or personal injury.

ATTENTION This indication alerts you to the fact if you ignore this detail you will affect the performance or functionality of the product.

All Ciro products are designed for "easy assembly" and/or "plug and play". We recommend a competent mechanic install our products, using standard mechanical procedures to assure a safe and successful installation. Read completely and understand the instructions prior to starting installation.

NOTE: Ciro products are designed and manufactured under very strict quality control. Ciro warrants that products sold to the original purchaser shall be free from any defects in materials and workmanship for a period of 3 (three) years from the date of purchase, and a limited lifetime warranty against LED failure. Ciro will have no obligation if the customer cannot show proof of purchase. Warranty will not be granted unless the part is properly installed and maintained. Ciro will not be liable for any consequential and incidental damages, including labor, or non-Ciro products. Please visit Ciro3d.com for our complete warranty policy.

CAUTION

Ciro is not responsible for improper loads or unsafe positioning of the Quick Release Waterproof Cooler. Be sure the weight of the contents placed in the bag do not exceed safe limits. It is the user's responsibility to determine what the safe limit is based on the position of the bag, proper securing of the bag and the weight limits given for the motorcycle by its manufacturer.

WARNING

It is the end user's responsibility to use good judgment. Follow the included mounting suggestions. Choose additional tie down straps that work for your application. Adhere to the vehicle manufacturer's GAWR and GVWR (gross axle weight rating and gross vehicle weight rating) when attaching luggage to a vehicle. Added weight, shifting loads, and improperly attached luggage can result in loss of control and can lead to serious injury or death.

WARNING

Prevent potential serious injury. Ensure the bag is fastened and straps are secure before riding the motorcycle.

Mounting Instructions:

1. Park on a level surface, allow the vehicle to cool.
2. Check the spacing of the mounts prior to installation. The hooks should be 4-4.5" apart, the latches should be 5-6" apart, Fig.1. Spacing may vary by application.
3. Unbuckle and slacken the securing straps on both sides of the bag, Fig.2.
4. Set the bag onto the luggage rack, hold the bag parallel to the luggage rack when setting it down. DO NOT tip the bag to either side when setting it down. Fig.3.

CAUTION

Bringing the bag down at an angle can cause contact with the top of the Tour-Pak lid. Fig.4.

5. Lift the bag slightly to loop both of the securing straps to the outermost rungs of the luggage rack, Fig.5. Do not buckle them at this time.
6. Make sure that the hooks and latches will capture the luggage rack when the bag is slid over.
7. With a smooth, firm motion, slide the bag to the left to secure the bag to the luggage rack, Fig.6. The hooks should slide under the luggage rack rung and the latches should capture the luggage rack rung with an audible latching sound. Illustrated in Fig.1.

8. Fasten the securing straps on both sides of the bag, capturing the release cord on the right side, Fig.7. Pre-load the straps by applying light downward force while the straps are tightened.

Note: To release the bag, unbuckle both securing straps and pull the release cord away from the bag, Fig.8.

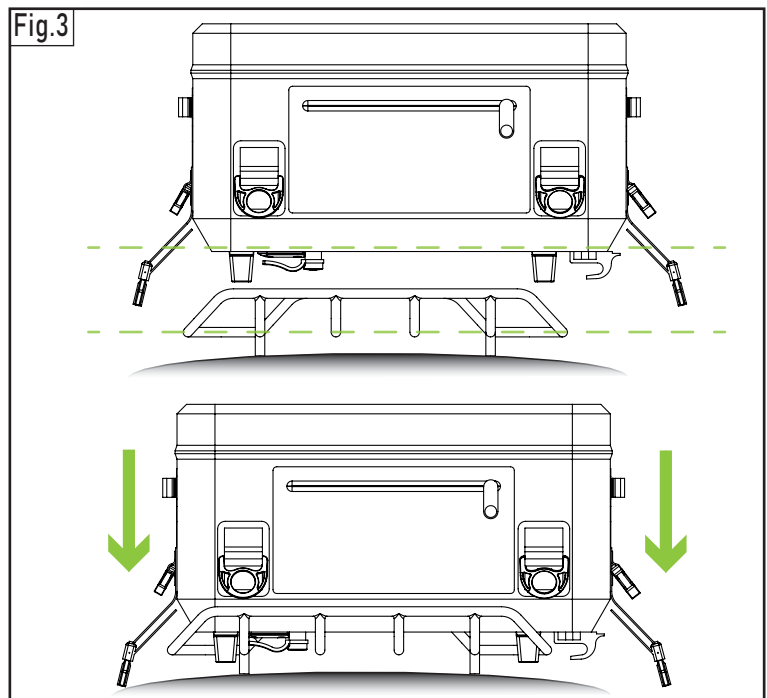

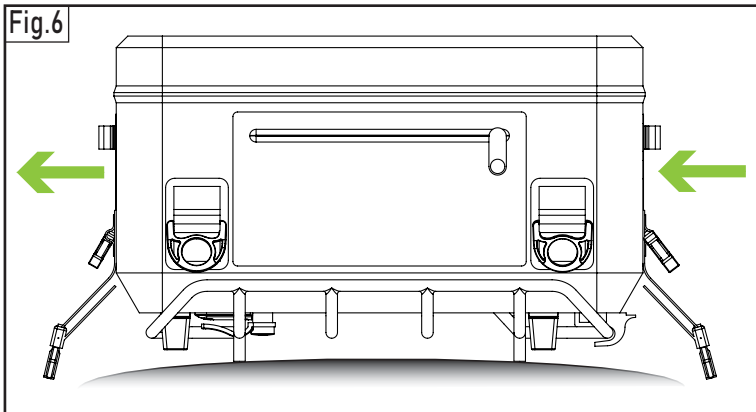
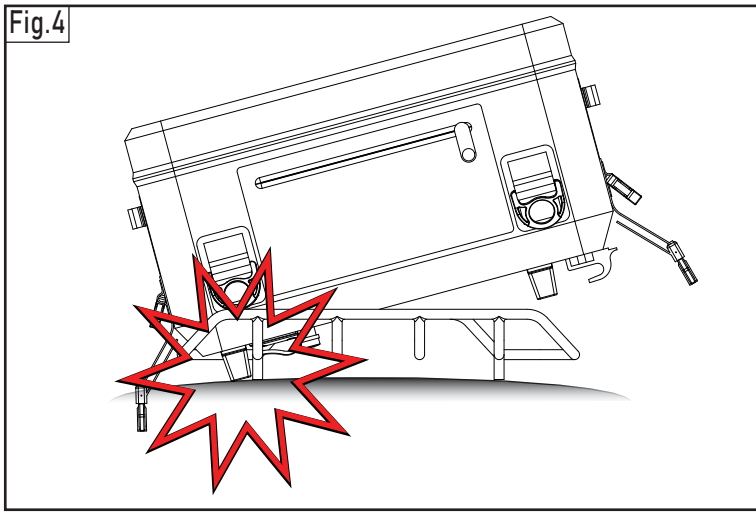

ATTENTION

Verify that the bag is securely attached before operating the motorcycle. Secure all straps away from painted surfaces, moving parts, pinch points or hot items. Check the straps before each ride and at each stop. Bag contents may shift during operation which can result in loose straps. Roll up any excess length in all of the straps and secure it.