

Items Supplied >

- 1 - RACK
- 4 - 1/4-20 BUTTON HEAD SCREWS
- 4 - 1/4" FLAT WASHERS
- 8 - RUBBER WASHERS

Application(s) >

- HARLEY:
TRIKE FREEWHEELER 15-19

Instruction Manual >

602-3000

Page 1 of 2

Read all instructions carefully and completely before installing your new Rack!

1. Open the trunk lid and remove any loose items from the trunk. Make sure to brace the trunk lid in the open position so that it will not move when installing the rack.
2. Find the 4 mounting bosses on the underside of the trunk lid. These are the drill locations for the rack. See **FIGURE 1**.

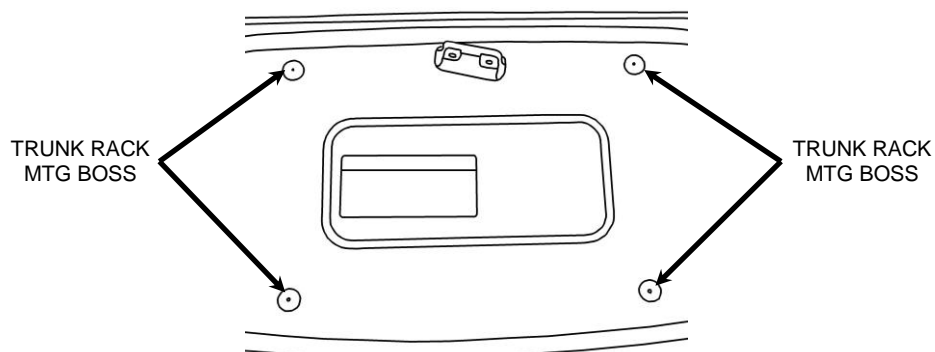

FIGURE 1

3. There should be a small indentation marking the very center of the bosses. Using a 1/16" diameter drill, very carefully drill 4 pilot holes from the underside of the trunk lid through the center of these indentations in the mounting bosses. Make sure to drill perpendicular to the underside of the trunk lid surface.
4. Apply masking tape over the holes on the top surface of the trunk lid to protect it from chipping. See **FIGURE 2**.
5. Using a 1/8" diameter drill bit, very carefully drill from the top of the trunk lid thru the pilot holes. Make sure to drill perpendicular to the trunk lid surface.
6. Next, using a 9/32" diameter drill bit, very carefully drill from the top of the trunk lid thru the pilot holes. Make sure to drill perpendicular to the trunk lid surface.

*** Cobra® recommends you always wear a helmet while riding. Please never operate your motorcycle while under the influence of alcohol and/or drugs. Enjoy the new look of your motorcycle and please ride safely.**

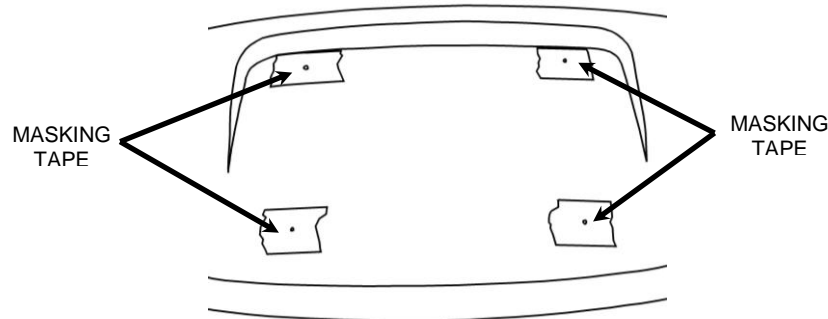

FIGURE 2

8. Carefully remove the masking tape from the trunk lid being sure the paint does not chip around the holes. Make sure to clean off any residue from the tape.
9. Locate the supplied rubber washers, flat washers, and 1/4-20 screws. Place 1 flat washer and then 1 rubber washer over each 1/4-20 button head screw. See **FIGURE 3**.
10. From the underside of the trunk lid insert each screw with flat washer and rubber washer through each of the holes and then place 1 rubber washer over the threads of the bolt from the top to hold it in place. See **FIGURE 3**.
11. Very carefully align the mounting legs of the rack with each screw and slowly tighten the screw. Make sure not to cross thread any screws. Snug each screw a little at a time, making sure the rack sits squarely onto the trunk lid surface and is straight. **DO NOT TIGHTEN** at this time. **NOTE:** If the screw will not thread into the mounting boss easily, the hole in the trunk lid may need to be enlarged with a small round file or a larger drill bit.
12. When all the screws are snug and the rack is straight on the trunk lid, tighten the screws until the rubber washers are compressed and the rack is secure. **DO NOT OVERTIGHTEN** the screws or the top trunk lid surface may get dented or scratched from the rack mounting legs.
13. Check the mounting screws after the first ride and after the first 500 miles to make sure the screws are still tight.

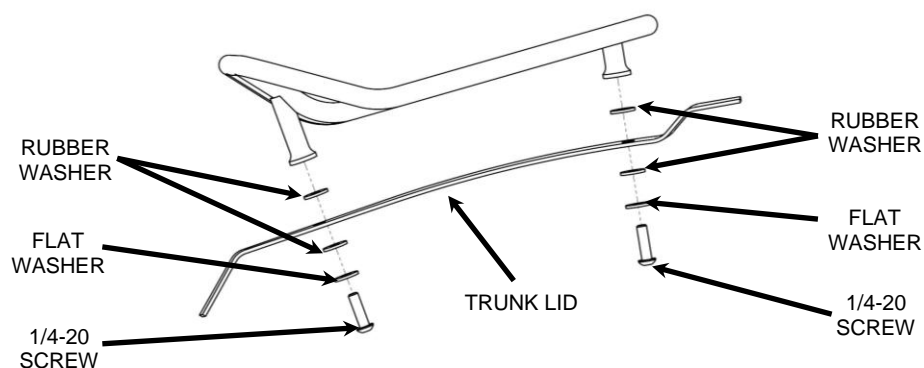

FIGURE 3

**DO NOT EXCEED THE MAXIMUM WEIGHT OF THE RACK
MAX WEIGHT CAPACITY OF RACK = 10 POUNDS.**