

Items Supplied >

- 1 – RIGHT MUFFLER ASSEMBLY
- 1 – LEFT MUFFLER ASSEMBLY
- 2 – CLAMP, 27-61MSC

Application >

HARLEY:
DRESSER 1995 - 2015

Instruction Manual >

6106

Page 1 of 1

Read all instructions carefully and completely before installing your new slip-on mufflers

1. Remove the saddlebags carefully.
2. Remove and save the mounting hardware securing the mufflers to the brackets. Loosen the stock muffler clamps then pull the stock mufflers free from the headpipes. The stock clamps will not be reused.
3. Slide the supplied 27-61MSC clamps over the slip-on mufflers and position them as shown in Figure 1 with the hex head facing inward and towards the ground. **DO NOT** use the stock clamps because they will not tighten the mufflers properly. Only use the supplied 27-61 MSC clamps.
4. Slide the mufflers onto the headpipes until the mounting holes align. Note: Indent on right muffler will face inward. Fasten the mufflers using the stock mounting hardware in the same manner as stock but **do not tighten**.
5. From the rear, rotate the mufflers as needed so they are level with the ground and parallel with each other.
6. Verify that the gap, where the mufflers meet the stock heatshields, is similar to the gap the stock mufflers allotted.
7. Check all clearances and alignments then tighten the mounting bolts to factory specifications. Tighten the muffler clamps. (NOTE: The muffler clamps should be flush with the end of the muffler when tightened. See **Figure 2**. If the muffler clamps are slid past the slots on the slip collar the clamps will not tighten the mufflers properly).
8. Reinstall saddlebags carefully.
9. **IMPORTANT: Before starting your engine remove all fingerprints from chrome with a quality wax or chrome polish. Failure to do so can cause chrome discoloration. Due to fluctuations in fuel delivery settings, timing, etc., Cobra Engineering does not warrant against chrome discoloration.**

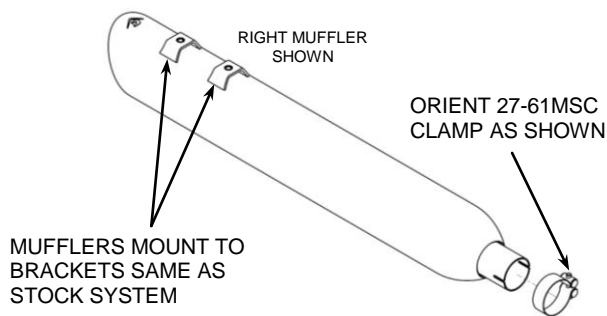

FIGURE 1

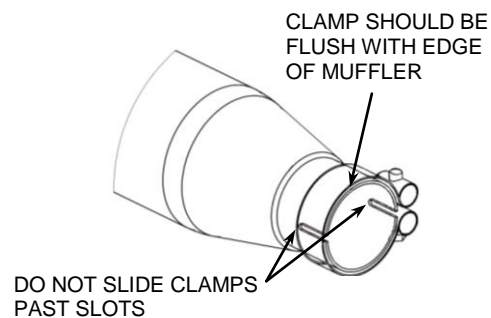

FIGURE 2

IMPORTANT: To achieve optimum performance from your new mufflers it is suggested that you install a Cobra Fi2000® Digital Fuel Processor.

California does not allow the use of aftermarket exhaust systems that remove original equipment catalysts, (except for racing use only) unless the Air Resources Board has issued an Executive Order for that system.

* **Cobra® recommends you always wear a helmet while riding. Please never operate your motorcycle while under the influence of alcohol and/or drugs. Enjoy the new look of your motorcycle and please ride safely.**