

Items Supplied >

- 1 - RIGHT MUFFLER ASSEMBLY
- 1 - LEFT MUFFLER ASSEMBLY
- 2 - CLAMP, 27-61MSC

Application(s) >

HARLEY:
FREEWHEELER 2015

Instruction Manual >

6300

Page 1 of 2

Read all instructions carefully and completely before installing your new Slip-On Mufflers!

1. Remove and save the mounting hardware securing the stock mufflers to the rear brackets. Loosen the stock muffler clamps then pull the stock mufflers free from the head pipes. The stock clamps will not be reused.
2. Position the supplied 27-61MSC clamps with the hex head facing the ground as shown in **Figure 1** and slide them onto the slip-on mufflers.
3. Slide the mufflers onto the head pipes (Cobra logo is on the right muffler and should face outward) until the mounting holes align.
4. Fasten the mufflers using the stock mounting hardware in the same manner as stock but **do not tighten**.
5. Adjust the mufflers so that the muffler tip extends out 1/4" past the end of the rear valence. See **Figure 3**. If the mufflers do not extend out past the end of the rear valence the heat from the exhaust may melt or distort the paint.
6. Also make sure the mufflers are not twisted around the centerline of the headpipes. Check to make sure there is an even gap around the muffler as it exits through the cutouts in the rear valence.

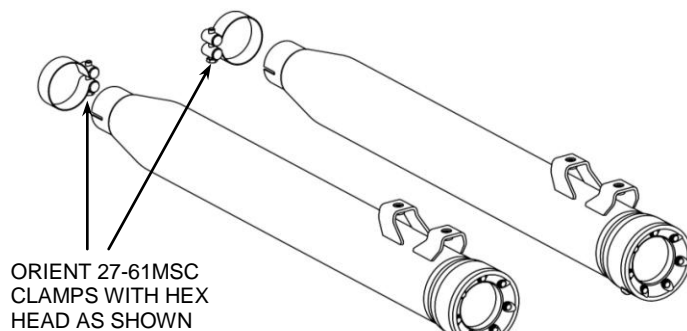

FIGURE 1

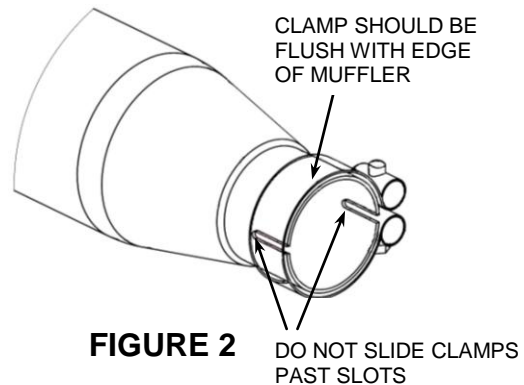
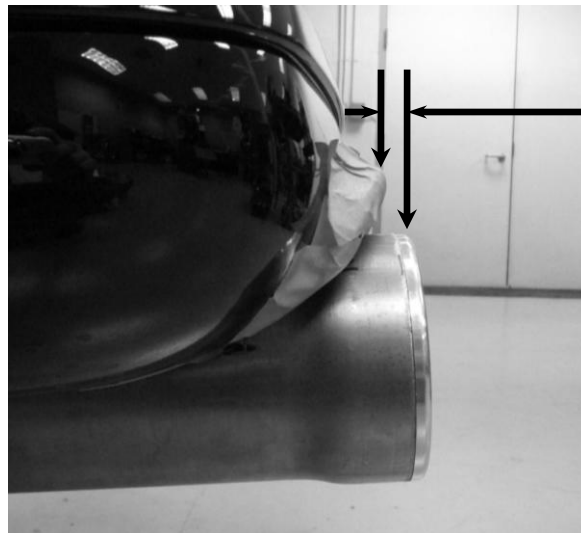

FIGURE 2

POSITION OF MUFFLERS AND MOUNTING BRACKETS SHOWN ABOVE MAY VARY FROM ACTUAL

Continued on Page 2

* **Cobra® recommends you always wear a helmet while riding. Please never operate your motorcycle while under the influence of alcohol and/or drugs. Enjoy the new look of your motorcycle and please ride safely.**



MUFFLER TIP MUST
EXTEND 1/4" PAST
REAR VALENCE

FIGURE 3

9. Check all clearances and alignments then tighten the clamps. (NOTE: The muffler clamps should be flush with the end of the muffler when tightened. See **Figure 2**. If the muffler clamps are slid past the slots on the slip collar the clamp will not tighten properly.)
10. Tighten the mounting bolts to factory specifications.
11. **IMPORTANT: Before starting your engine remove all fingerprints from chrome with a quality wax or chrome polish. Failure to do so can cause chrome discoloration. Due to fluctuations in fuel delivery settings, timing, etc., Cobra Engineering does not warrant against chrome discoloration.**

IMPORTANT: It is recommended that a Cobra Fi2000® Closed Loop Digital Fuel Processor be installed with the Cobra exhaust system. www.fi2000r.com.

California does not allow the use of aftermarket exhaust systems that remove original equipment catalyts, (except for racing use only) unless the Air Resources Board has issued an Executive Order for that system.