

Items Supplied >

- 1 – Powrpro Black Fuel Injection Module
- 2 – Zip Ties
- 1 – Velcro Strip

Application(s) >

HARLEY	SOFTAIL	01-05
	DYNA	04-05
	Fuel Injection -	Models

Instruction Manual >

692-1605B

Page 1 of 3

Read all instructions carefully and completely before installing your new POWRPRO module. It is recommended that a qualified mechanic or technician install this product.

1. Remove the seat and air cleaner assembly.
2. Remove both front and rear gas tank mounting bolts.
3. Prop the rear of the gas tank up approximately 2”.
4. Locate the factory connector on each fuel injector. Depress the wire clip on the injector and pull the connector free and move it out of the way. **Note:** A pair of needle nose pliers and a long flat blade screwdriver helps with this job. If you need additional access to the fuel injector connectors, you can remove the Idle Air solenoid by removing the two 5/16” bolts holding it on and loosening the Torx #20 screw on the throttle cable bracket. Make sure to use blue thread-locking compound when refitting the two 5/16” bolts and correctly position the o-ring when reattaching.
5. Lay the Fi2000 module in place, but do not attach it to the motorcycle at this time, run the wiring harness up to the manifold area behind the other wiring of the throttle body, (see Figure 1 for Softail and Figure 2 for Dyna.) Attach one pair of the Fi2000 module’s injector plugs to the front injector. Take the original HD connector and insert the corresponding Fi2000 connector into it (refer to Figure 3).
6. Attach the Fi2000 module’s remaining injector plug to the rear injector. Then take the original HD connector and insert the corresponding Fi2000 connector into it, (refer to Figure 3).
7. Attach the black wire to the negative post of the battery on Softail models, (see Figure 1). On Dyna models, route the black wire down behind the factory ECU until it appears below the coil/electrical box on the left side and attach to the upper ground lug on the frame, (see Figure 4).
8. Verify that the module has power and connections have been made correctly; watch the clear window on the FI housing and turn "ON" the key ignition and set the handlebar run switch to "ON", confirm that the Red LED turns on. On some models the Red light will turn off after 4-5 seconds as the fuel pump cycles off, which is OK. If you do not see a Red light, it may be necessary to wait for the alarm to reset (if applicable) and try again. Also confirm the side stand is up, bike is in neutral, and clutch is in. Start the bike and confirm the LED remains on solid Red. **NOTE:** Make sure ignition is turned off before attempting to change any Fi2000 harness connections if no Red light is seen. For access to the Blue Tooth Tuning App on the module, please download the PowrPro Black App to your smart device, Android 4.3 & later or Apple iOS 5.0 & later operating systems. Once the app is installed, make sure the motorcycle is in neutral and start the engine, use the connect button within the app and the Blue light on the Fi module window will light up during pairing connection and remain solid Blue while paired and connected with respective Android or Apple Device. Once the app has been used and settings saved and disconnected through the app, the Blue light will turn off, and the PowrPro Black will be ready for continued service on the motorcycle.

DISCLAIMER: NOT LEGAL FOR SALE OR USE IN CALIFORNIA ON ANY POLLUTION CONTROLLED MOTOR VEHICLES.

10. Route the Fi2000 wiring harness alongside the factory harness using the supplied zip ties, keeping it off the cylinder head or getting it pinched under the gas tank. Lower and re-attach the fuel tank.
11. Remove the backing from the Velcro and attach the Fi2000 as shown for Softail in Figure 1 and Dyna in Figure 2.
12. Re-install the seat and air cleaner assembly.

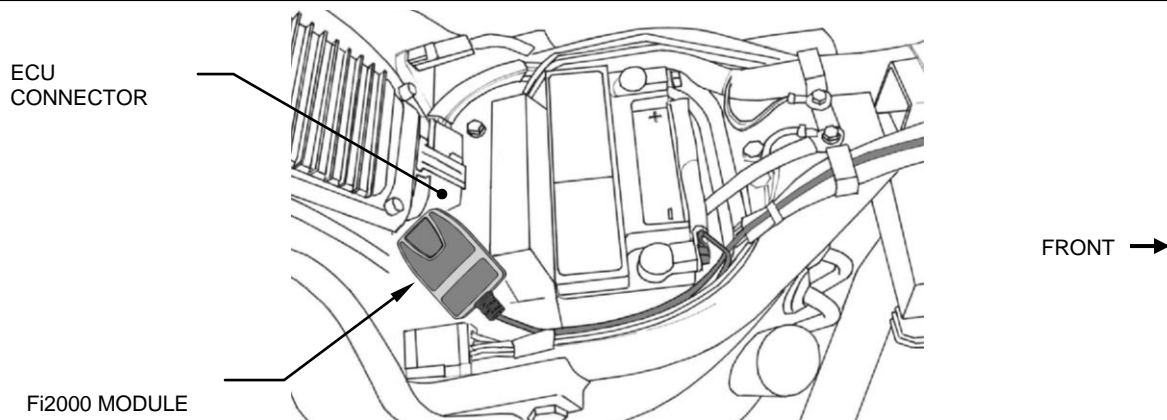

FIGURE 1
(SOFTAIL 01 and 05)

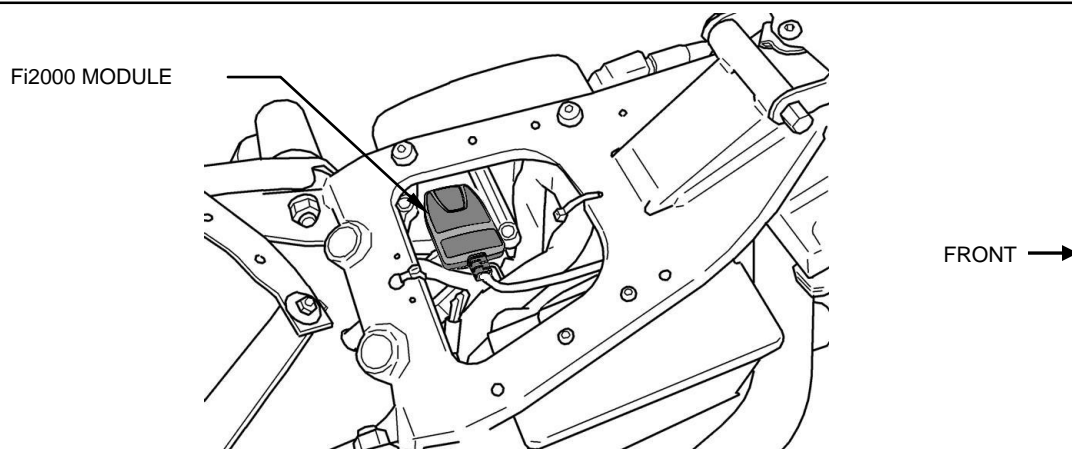

FIGURE 2
(DYNA 04 and 05)

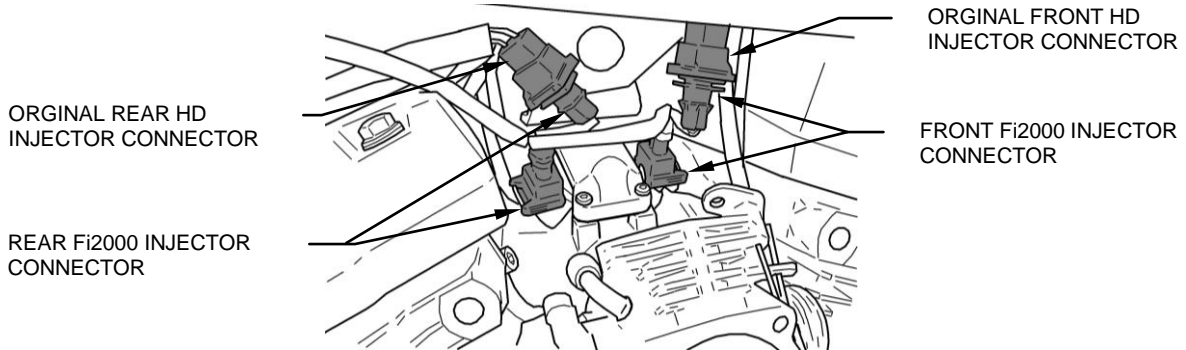

FIGURE 3

(SOFTAIL and DYNA w/Fi2000 installed with Air Injector Solenoid removed)

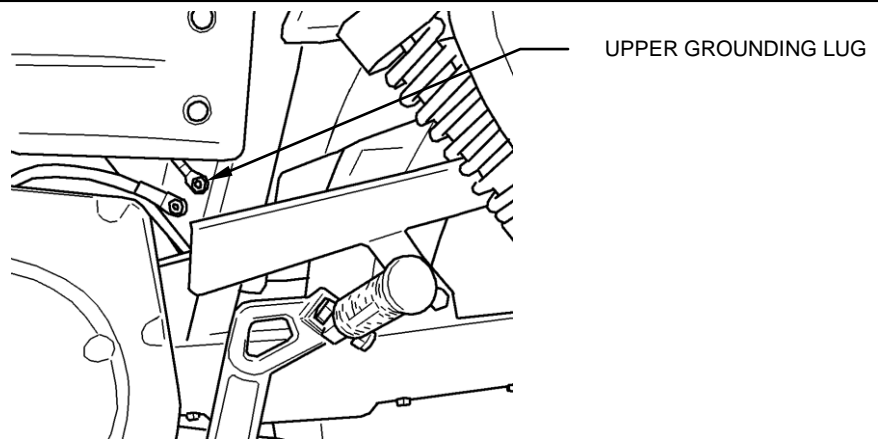

FIGURE 4

(DYNA 04 and 05)

DISCLAIMER: NOT LEGAL FOR SALE OR USE IN CALIFORNIA ON ANY POLLUTION CONTROLLED MOTOR VEHICLES.