



Custom Dynamics® Indian® Dynamic Load Isolator Installation Instructions

We thank you for purchasing the Custom Dynamics® Indian® Dynamic Load Isolator! Our products utilize the latest technology and high quality components to ensure you the most reliable service. We offer one of the best warranty programs in the industry and we back our products with excellent customer support, if you have questions before or during installation of this product please call Custom Dynamics® at 1 (800) 382-1388.

Part Number: CD-DLI-CHAL

Package Contents:

- Dynamic Load Isolator (DLI) (1)

Fits: 2020-2022 Indian® Challenger, Challenger Dark Horse & Challenger Limited models, 2022 Chief, Chief Dark Horse, Chief Bobber & Chief Bobber Dark Horse. 2022 Indian Pursuit Limited & 2022 Indian Pursuit Dark Horse

COMPATIBLE WITH ANY ELECTRICAL ACCESSORY UP TO 10 AMPS.

45 AMP TOTAL MAXIMUM OUTPUT CAPACITY



ATTENTION



Please read all Information below before Installation

Warning: Do not exceed 45 amp load. Doing so could cause the unit to overheat.

Important: Module must be secured after installation.

Important: DO NOT attempt to make changes to the input side of the Dynamic Load Isolator. Doing so will cause malfunction of unit.

Note: If a Brake Strobe unit is plugged in front (before) the DLI, both the bike's rear harness and any brake accessories attached on the output side of the DLI will have the brake strobe pattern. If the Brake Strobe unit is plugged in behind (after) the DLI, only the rear harness of the bike will have the brake strobe pattern.

Note: Run/Brake/Turn units must be plugged in behind (after) the Dynamic Load Isolator.

Note: Each wire port can accept multiple wires depending on the gauge of the wire.

Note: While some wiring examples are included, follow the directions included with each accessory you are adding to the Dynamic Load Isolator.

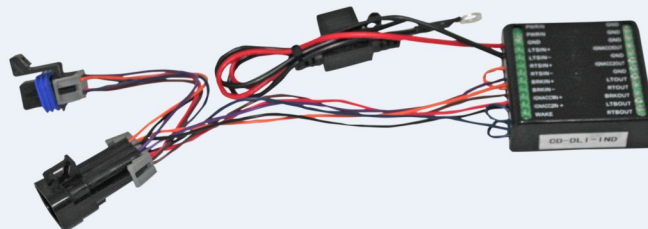

Installation:

1. Secure motorcycle on level surface.
2. Remove seat.
3. Disconnect negative [-] battery cable from the battery.
4. Locate and unplug the lighting connector to the rear fender under the seat (see Picture 1 on Page 2).
5. Plug the DLI™ module, in-line, into the rear lighting harness plug and the bike's main wiring harness plug.
6. Refer to typical output wiring configuration diagrams on Page 3 and 4 that best fits your application.
7. To connect the wires to the Dynamic Load Isolator, use a small straight slot or Phillips screw driver to turn the output bank screw counter-clockwise until the wire port is fully open (see Picture 2 on page 2).
8. Place the wire of the accessory in the wire port of the Dynamic Load Isolator and turn the screw clockwise until it is tight against the wire.
9. Once all of the output connections have been made, connect the single Red fusible wire of the Dynamic Load Isolator to the positive battery post.
10. Attach the single Black wire of the Dynamic Load Isolator to the ground side of the battery.
11. Connect the battery's negative battery cable along with the single Black wire of the Dynamic Load Isolator to the negative [-] of the battery.
12. Locate a secure place for the Dynamic Load Isolator unit that will not interfere with the secure placement of the seat.
13. Reinstall seat.
14. Check operation of all lighting before riding.

Questions? Call us at: 1 (800) 382-1388 M-TH 8:30AM-5:30PM / FR 9:30AM-5:30PM EST

Installation Instructions - Page 2

Dynamic Load Isolator Port functions:

GND: Four Ground Outputs.

IGNACCOUT 1 & 2: 12 volt switchable power sources that can be used for accessories or running light operation.

LTOUT: Left turn/brake signal operation.

RTOUT: Right turn/brake signal operation.

BRKOUT: Brake signal operation only.

LTBOUT: Left turn signal and Brake operation with turn signal over riding the brake signal for the left side. The right side will still receive a brake signal.

RTBOUT: Right turn signal and brake operation with turn signal over riding the brake signal for the right side. The left side will still receive a brake signal.

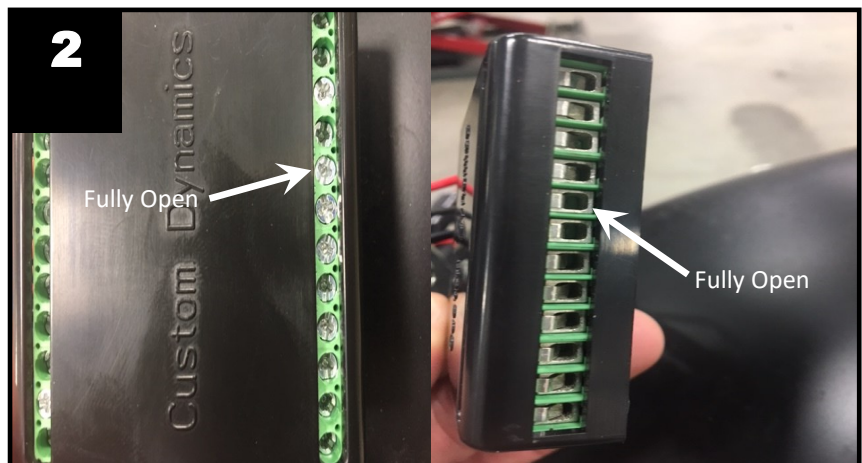
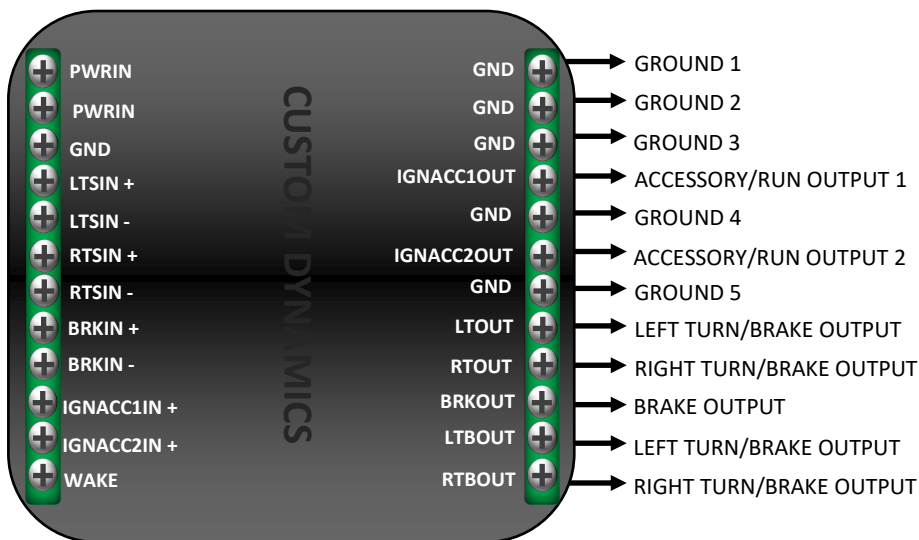

Questions? Call us at: 1 (800) 382-1388 M-TH 8:30AM-5:30PM / FR 9:30AM-5:30PM EST

4 Pin Trailer Harness

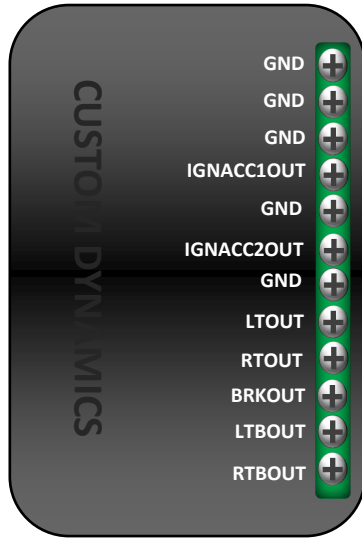

4 Pin Trailer Harness (optional):

- White wire - Ground
- Green wire - Right turn signal and brake signal
- Yellow wire - Left turn signal and brake signal
- Brown wire - Running light circuit

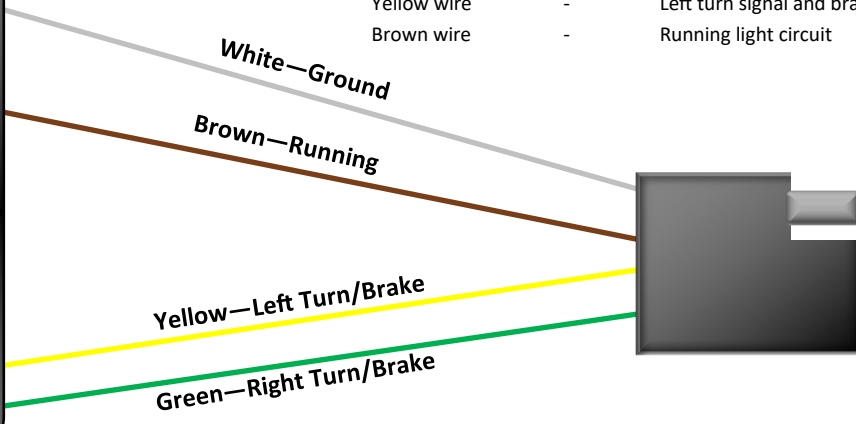

Run Operation:

Single Intensity LEDs

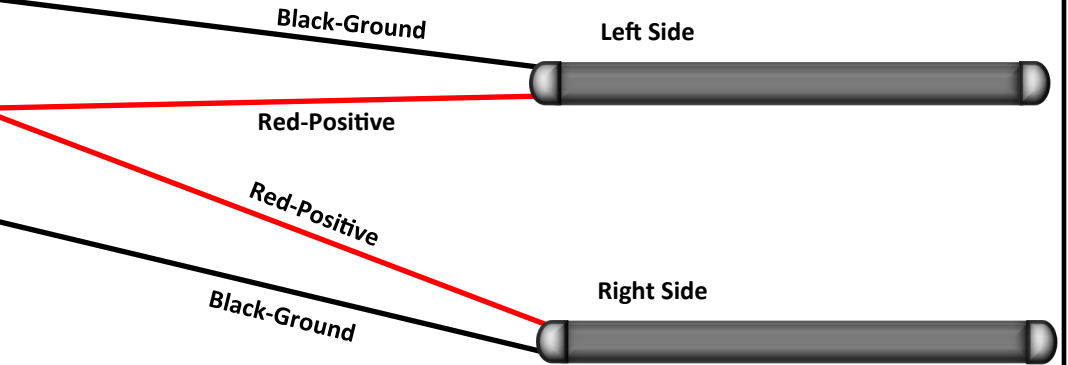
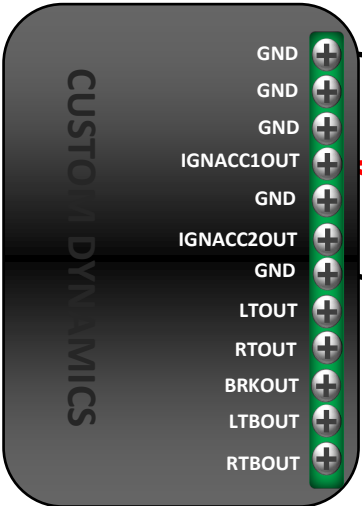

Turn/Brake Operation:

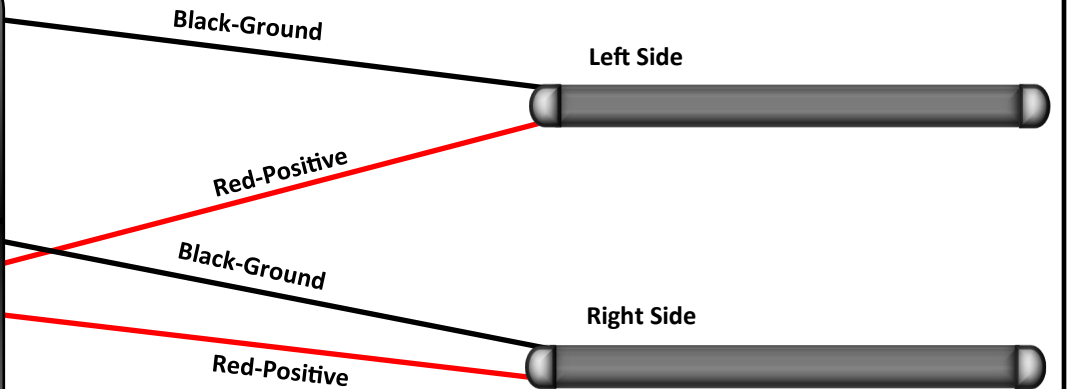
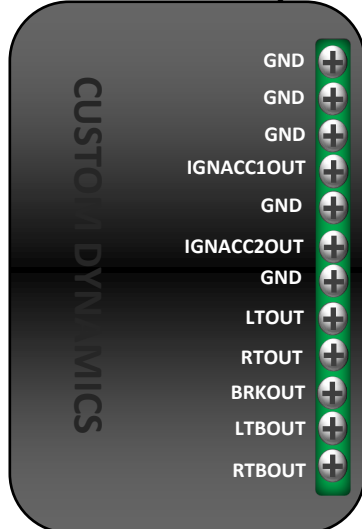

Installation Instructions - Page 4

Dual Intensity LEDs

Run-Brake Operation:

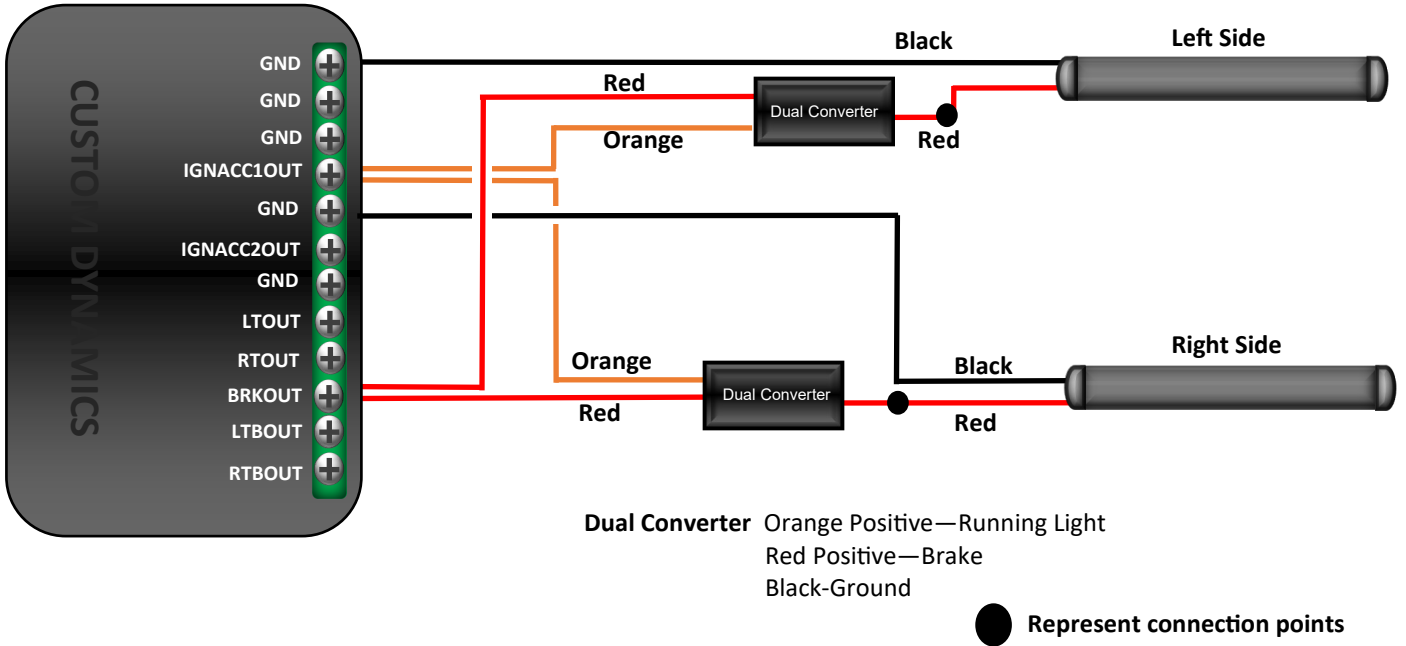

Dual Intensity LEDs

Run-Brake-Turn Operation:

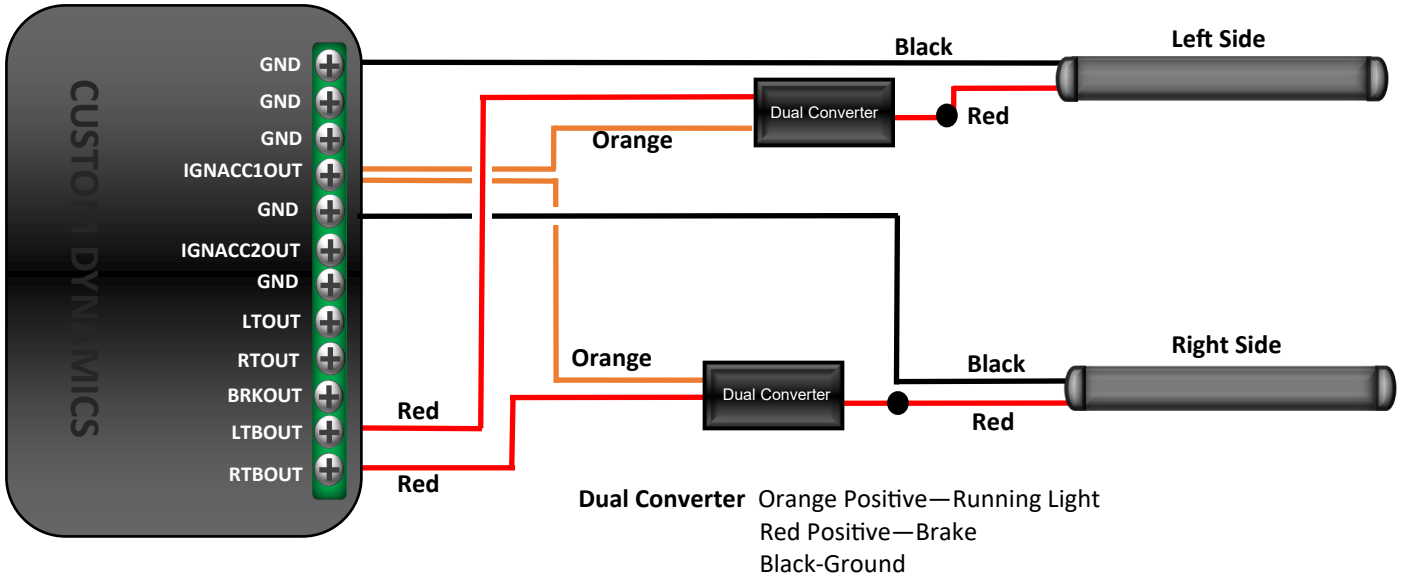

Note: While some wiring examples are included, follow the wiring directions included with each accessory added to the Dynamic Load Isolator.