



Custom Dynamics® TruBEAM® LED Headlamp Installation Instructions

We thank you for purchasing the Custom Dynamics® TruBEAM® LED headlamp! Our products utilize the latest technology and high quality components to ensure you the most reliable service. We offer one of the best warranty programs in the industry and we back our products with excellent customer support, if you have questions before or during installation of this product please call Custom Dynamics® at 1(800) 382-1388.

Part Number: CDTB-7

Package Contents:

- TruBEAM® LED Headlamp (1)
- Instructions

Fits: **Harley-Davidson®:** 1981-2019 Electra Glides®, Ultra's, and Street Glides®, 1994-2019 Road Kings®, 2009-2019 TriGlide® & Freewheeler®, 2004-2017 CVO Models (except Springer®, Dyna®, Road Glides®, Convertible®, and Breakouts®), 2012-2016 Dyna Switchback®, 1984-2017 FL Softail® models with 7" buckets.

Yamaha®: 1999-2013 Road Star® models (except Warrior, Tour Deluxe, and MM) and 1998-2011 V-Star® 650/1100 Classic & Silverado



Please read all Information below before Installation

Important: Due to the increased light output from this unit, it is recommended you take the vehicle to a dealer to have the headlamp properly adjusted. Weight and tire pressure can affect the position of the light.

Warning: To prevent possible electrical shock, disconnect the negative Battery terminal before installing this product.

Fitment Note: 2014-2019 Harley-Davidson® Street Glide®, Electra Glide®, and TriGlide® Models require **H4-TOUR-ADPT** for plug and play installation of TruBEAM® Headlamp. (see page 2)

Fitment Note: 2014-2019 Road King® models require **CDTB-H42H9H11** adapter for plug and play installation of TruBEAM® Headlamp. (see page 2)

Fitment Note: To keep high and low beam on at same time on 2013 and earlier Harley-Davidson® touring models and 2014-2019 TriGlide® and CVO™ touring models use Hi/Lo/Halo adapter **CDTB-HLA-1**

Fitment Note: To enable TruBEAM® halo ring and keep high and low beam on at same time on Softail® and Dyna® models with 7" headlamp use Hi/Lo/Halo adapter **CDTB-HLA-1**

Fitment Note: On some 1981-2013 HD Touring fairings, the mounting ring hole may require trimming to accept the headlight. See Page 3.

Fitment Note: Not compatible with Harley Davidson® Garage Door Opener four-wire transmitter from Transmitter/Receiver Kits 91558-01 and 91558-01A or Transmitter Kit 91561-01.

Installation

1. Disconnect the vehicle battery negative [-] terminal.
2. Review detailed service manual for instructions on replacing factory headlamp.
3. Remove the factory headlamp from vehicle.
4. Before installing TruBEAM®, locate the vent on the rear of the unit and remove the white rubber cover so that the vent will function properly.
5. Connect the TruBEAM® headlamp to the existing factory H4 plug and re-install according to your vehicles manual.
6. LED Halo (Optional): Locate the white wire on the back of the TruBEAM® headlamp. Power this wire by attaching it to accessory/running light power or to the CDTB-HLA or H4-TOUR-ADAPTER (sold separately). See adapters instructions for installation.

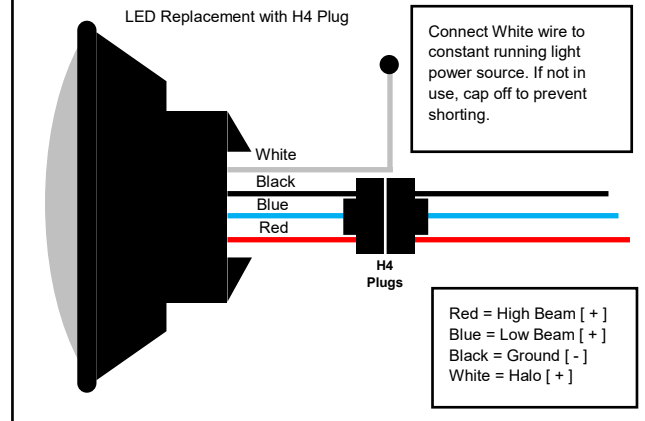

Questions? Call us at: 1 (800) 382-1388 M-TH 8:30AM-5:30PM / FR 9:30AM-5:30PM EST

Installation Instructions - Page 2

7. Re-assemble headlamp per the instructions in detailed factory service manual. Make sure no wire or any components of the headlamp can be pinched during installation and that they will not be exposed to water spray, excessive heat or moving parts.
8. Re-connect vehicle battery negative [-] terminal.
9. Test function of head lamp for high beam and low beam function:
 - Stock function without adapter = When low beam is ON, high beam is OFF, when high beam is ON, low beam is OFF.
 - Function when Using CDTB-HLA = When low beam is ON, high beam is OFF. When high beam is ON, low beam is ON.
 - Halo Function = Halo will only work if connected running power is applied to the white wire. Function is optional.

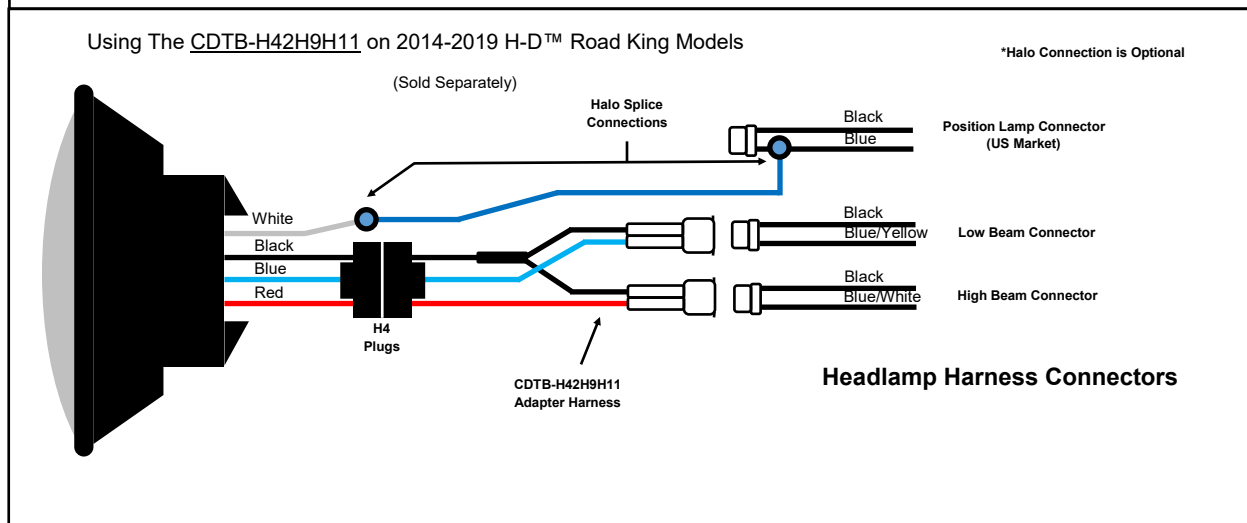
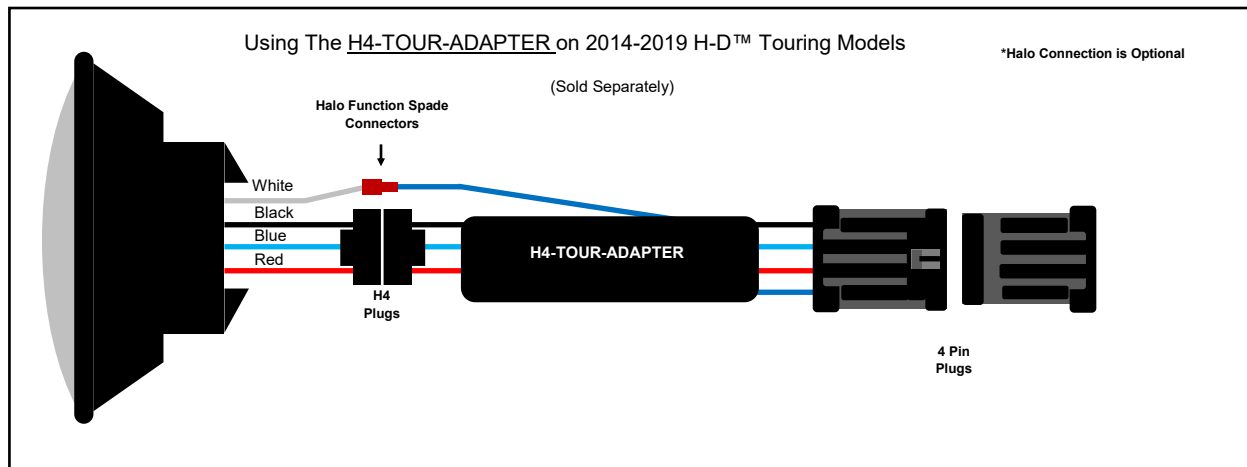

Questions? Call us at: 1 (800) 382-1388 M-TH 8:30AM-5:30PM / FR 9:30AM-5:30PM EST

Installation Instructions - Page 3

Fitment Note - 1981-2013 HD Touring Models with Batwing Fairing

On some 1981-2013 HD Touring models with stock batwing fairing, the inner mounting ring hole may need to be enlarged for the new TruBEAM® headlight to fit properly. If you experience a gap between the light's mounting tabs and the mounting ring (see the photo to the right) you should remove the mounting ring assembly from the fairing, by removing the 5 screws.

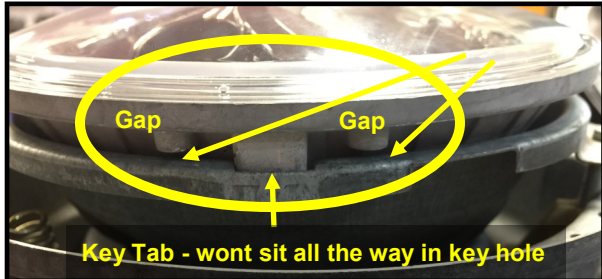

Next, using a file or preferably a Dremmel tool, remove about 1 mm of metal from the complete circumference of the opening. Test fit after the initial run to see where additional modification may need to be made. When there is no gap left in the Key opening in the mounting ring and the key tabs on the headlight fitment is good.

Remount the mounting ring to the Fairing and continue installation of headlight.



Everything to Light Up Your Ride®

