



## Custom Dynamics® Magical Wizards™ Off Road Accent Lights Kit Installation Instructions

We thank you for purchasing the Custom Dynamics® Magical Wizards™ Off Road Accent Lights Kit. Our products utilize the latest technology and high quality components to ensure you the most reliable service. We offer one of the best warranty programs in the industry and we back our products with excellent customer support, if you have questions before or during installation of this product please call Custom Dynamics® at 1(800) 382-1388.

**Part Number:** MWZ-OR-02

### Package Contents:

- 6 LED Heavy Duty Magical Wizard™ Light (10)
- 12 LED Heavy Duty Magical Wizard™ Light (6)
- 36 LED Heavy Duty Magical Wizard™ Light (2)
- Water Tight CCM6-W-BT Magical Color Command Remote
- Dielectric Grease Tube (1)
- 3M™ Tape Primer Ampule (3)

### CD101-WZ Install Kit

- 3 Position Cage Clamp® Connectors (4)
- Heat Shrink Terminals (2)
- Blue Butt Splice Connectors (2)
- SW02 Weatherproof Switch (1)
- 3M™ Tape Primer (2)
- 4" Black Cable Tie (20)

**Fits:** Compatible with 12VDC systems with a negative ground.

### Installation of LEDs:

1. Select hidden locations to mount LED Accent Lights to provide the best coverage of your choice.
2. Using the provided 3M™ adhesive promoter ampule, clean the locations selected and allow to dry. Do not touch promoter with fingers.
3. Remove the red backing from the LEDs and apply to the selected surfaces. Keep in mind the direction of the wires, they will all need to face the same direction pointing back to a central location for connection. Press lightly on each unit along the total surface of the LED for 10 seconds to ensure proper contact.
4. Route wires from the LED's back to a central point close to the battery. Select locations to secure the wires to the frame using the provided cable ties. Make sure the wiring is clear of any moving parts and does not interfere with normal operation.
5. Select the location close to the battery, then cut off any excess wiring to the LED. Strip the wires back to the appropriate length to prepare for termination.

### Wiring the LEDs

6. Using the 3 Cage Clamp® connectors (included), label each clamp with a number 1 through 4. If you need instructions on how to use the Cage Clamps®, see diagram to the right. You can double up as many wires as you can on each port of the connector to allow space for all the LEDs. Leave at least 1 port open on each of the connectors to allow for the remote wiring.

**Note:** Apply dielectric grease (included) to all wire ends before connecting to cage clamps.

7. Join all of the LEDs BLACK wires into Cage Clamp® #1,
8. Join all the RED wires from LEDs to Cage Clamp® #2,
9. Join all the BLUE wires from LED's to Cage Clamp® # 3
10. Join all the GREEN wires from LEDs to Cage Clamp® #4.
11. Make sure all connections are secure in the clamp and will not pull out.



## ATTENTION

Please read all Information below before Installation

**Note:** Magical Wizard™ LEDs use the black wire for power and the colored wires for grounds. Please read instructions and diagrams before beginning installation.

**Important:** In order for the weather proof 3M™ tape to cure properly, make sure that the controlled or ambient install temperature is 60 degrees F or higher. Allow 24 hours for tape to cure before washing or prolonged use of vehicle.

**Important:** Disconnect negative battery cable from battery before installation; refer to owner's manual if unsure of this process. Failure to do so may result in electrical shock, injury, or fire. Secure negative battery cable away from positive side of battery and all other positive voltage sources on bike.

**Safety:** Always follow safe working practices including safety gear and the proper tools. Make sure vehicle is cool enough to touch. Make sure it is secured on a level surface.



Strip wire 9-10 mm. Use wire gauge on bottom to verify.

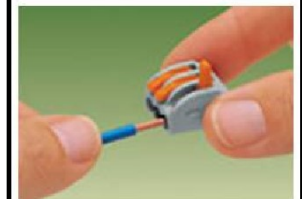

Push Lever up and insert wire...



Then push down lever to its closed position.

Questions? Call us at: 1 (800) 382-1388 M-TH 8:30AM-5:30PM / FR 9:30AM-5:30PM EST

## Installation Instructions - Page 2

### Wiring Remote—CCM6-W-BT (Bluetooth version)

The CCM (Color Command Module) has wires coming out of the black box that get connected to the LED wiring. Strip back enough insulation on the wires and terminate as follows:

**NOTE:** When the CCM remote has power, it will constantly search for a key fob signal. Over long periods of down time, such as storing vehicle over the winter, this will drain the battery. See SW02 (waterproof switch) install below.

**Note:** Apply dielectric grease (included) to all wire ends before connecting to cage clamps.

- RED wire with Fuse - Connect to the [ + ] Positive terminal of 12Volt battery or power source.
- BLACK wire - Connect to suitable ground or [ - ] Negative terminal of 12Volt battery or power source.
- WHITE wire - Connect to Cage Clamp® #1, the BLACK wires from the LEDs.
- RED wire - Connect to Cage Clamp® #2, the RED wires from the LEDs.
- BLUE wire - Connect to Cage Clamp® #3, the BLUE wires from the LEDs.
- GREEN wire - Connect to Cage Clamp® #4, the GREEN wires from the LEDs.
- YELLOW wire - Connect to the vehicle brake positive [ + ] wire to enable.

**SW02 Installation:**

- Cut the Red power wire between the Fuse holder and the CCM-6BT Brain Box (see diagram below).
- Use butt splice or wire tap to connect the switch to the red wire on the connector side of the harness.
- Use butt splice or wire tap to connect the other side of the switch to the fuse holder side of the harness.
- Mount the switch in convenient location with the included double-sided tape. Prime the surface first with the 3M™ primer ampule and allow to dry.

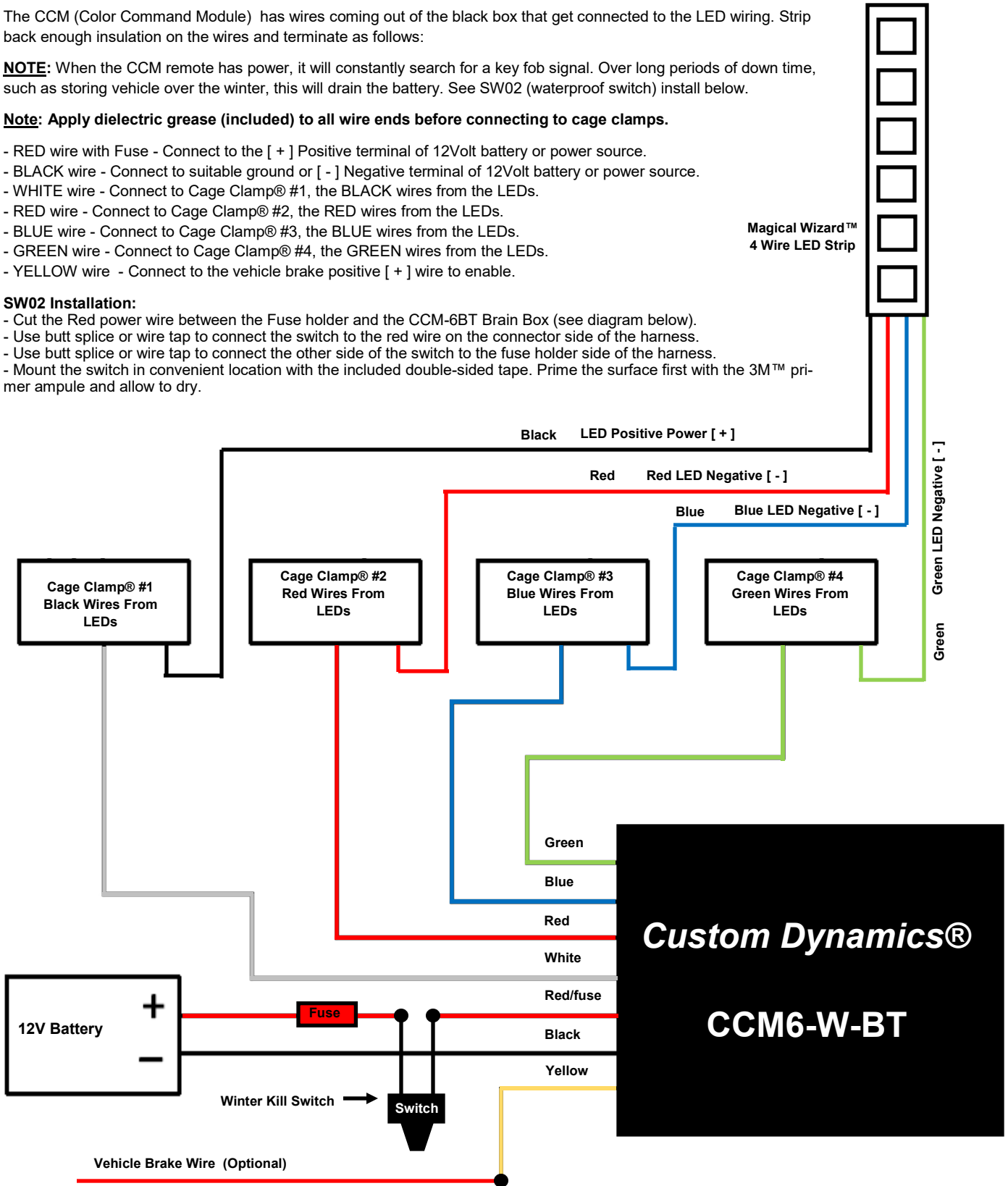

Questions? Call us at: 1 (800) 382-1388 M-TH 8:30AM-5:30PM / FR 9:30AM-5:30PM EST

# Installation Instructions - Page 3

## Finish and Test

1. Inspect all connections, make sure nothing is loose, frayed, pinched or cut, A direct short will prevent the unit and LED's from functioning properly.
2. Re-connect the Negative [ - ] cable to the battery. Turn the vehicle power on and test function with the key fobs.

**NOTE:** See instructions that come with the CCM-6BT on using the key fobs or apps.

3. Once the system has been tested, dress the wires with provided tie-wraps as needed. Make sure the receiver and wiring are tucked out of the way from any heat or moving parts.

If installed under the seat, make sure that there is enough clearance for the wiring and remote box without crushing or pinching any of the components or connections. This is very important! A frayed or pinched wire can short the entire lighting system.



## Troubleshooting

This section will go over a few of the most common troubleshooting issues with the Magical Wizard™ LEDs and the CCM remote and give tips to help get your system up and running. If after you have tried any of these and still have issues, call Custom Dynamics® for technical support.

Symptom: Key Fob Light not coming on \_\_\_\_\_ Remedy: Check and replace key fob batteries

Symptom: Dim or pulsing blue light on key fob \_\_\_\_\_ Remedy: Check and replace key fob batteries

Symptom: Dim lights or lights not turning off completely \_\_\_\_\_ Remedy: Grounding issue - With process of elimination, trace back all LED wires checking for nicks or cuts in wires. If nothing is found, remove LED's 1 by 1 and test system function each time.

Symptom: Lights only get certain colors when on \_\_\_\_\_ Remedy: Inspect wires in all cage clamps, make sure all wires are pushed into sockets completely. Start with color you are not getting, red, green or blue.

Symptom: Lights not coming on, key fob lights up \_\_\_\_\_ Remedy 1: Inspect the wires in the cage clamps. Make sure red and black wires are pushed into the sockets all the way. Also double check connections at the battery.

Remedy 2: Check and or replace 3 amp in-line fuse.