

PROBEAM[®]

BY CUSTOM DYNAMICS[®]

Custom Dynamics[®] ProBEAM[®] Fillerz[®] LED Inserts Installation Instructions

We thank you for purchasing the Custom Dynamics[®] ProBEAM[®] Fillerz[®] LED Inserts! Our LEDs offer maintenance free service and higher visibility. Our ProBEAM[®] product line utilizes the latest technology and automotive grade components to ensure the highest level of reliable service. Custom Dynamics[®] offers one of the best warranty programs and customer support in the industry. If you have any questions during the installation of this product please call us at 1(800) 382-1388.

Part Number: PB-FILL-R-B PB-FILL-S-B
PB-FILL-R-C PB-FILL-S-C
US Patent D814673, D824553

Package Contents:

- ProBEAM[®] Fillerz[®] LED Inserts (1 pair)
- MPR-BCM-PLUG 6 Pin Adapter (1)
- 4" Cable Tie (8)
- 3M[™] Promotor Ampule (1)

Fitment: 2014-2019 Road King[®], Electra Glide[®], Ultra[®] and Road Glide[®].

Also fits CVO[™] Models (If painted filler panels are removed and BCM has not be re-programmed from stock programming).



ATTENTION

Please read all Information below before Installation

Note:

- Functions as Run/Turn on 2014-2019 Road King[®] Standard, 2014-2015 Limited CVO[™], & 2015 Road Glide Ultra CVO[™] (ProBEAM[®] Eclipse[®] required for run, brake, turn function - sold separately, see page 4).
- The ProBEAM[®] Fillerz[®] are designed to be secured in place by the 3M[™] backing tape on the Fillerz[®] Inserts, not by the alignment tabs (See Photo 3).
- This product is designed and intended for motorcycle auxiliary lighting use only. This product is **NOT** intended to replace any OEM lighting installed on the motorcycle and should not be used for that purpose. This product must be wired in such a manner that it does not interfere with any OEM lighting.

*****IMPORTANT*****

CAN Bus Models: This LED product is BCM compliant. However, you must run the 4 way hazard flashers for 3 minutes to allow the BCM to sync the new load after the new LED turn signals are installed.

Non-CAN Bus Models: A SMART Signal Stabilizer[®] or Load Equalizer is required to ensure proper turn signal function and have the proper flash speed.



Questions? Call us at: 1 (800) 382-1388 M-TH 8:30AM-5:30PM / FR 9:30AM-5:30PM EST

Installation Instructions - Page 2

Installation:

1. Remove the hard bags to allow access to the bag support brackets on the fender.
2. Remove the main seat on the bike and locate the 6 pin connector going to the rear fender. Unplug and install the MPR-BCM-PLUG adapter in line (See Photo 2).
3. Clean the surface area of the bag support bracket areas with ISO alcohol and allow to dry. Apply the provided 3M™ promoter onto the surface of the fender support areas, allow to dry.
4. Verify Left and Right Fillerz® panels before installing (See Photo 3).
5. Remove the red protective film of the 3M™ tape from the back of Fillerz®. Line up the bottom edge of Fillerz® with bottom edge of bag support bracket. Push Fillerz® into place until the alignment tabs click (See Photo 3). Apply pressure evenly over the Fillerz® to ensure the tape is applied evenly.
5. Route the wires from Fillerz® along the fender struts to the MPR-BCM-PLUG location. Secure the wires with the provided 4" cable ties.
6. Connect the left side Fillerz® to the MPR-BCM-PLUG 3 pin connector that has a purple wire. Connect the right side Fillerz® to the 3 pin connector with the brown wire.
7. Functions as Run/Brake/Turn on 2014- 2019 Electra Glide® Ultra Classic®/Low, Ultra Limited/Low, 2016-2019 Road Glide® Ultra, 2016 Road Glide Ultra CVO™, 2016-2019 Limited CVO™. Functions as Run/Turn on 2014-2019 Road King® Standard, 2014-2015 Limited CVO™, & 2015 Road Glide Ultra CVO™ ([ProBEAM® Eclipse](#) required for run, brake, turn function - sold separately) (see page 4).

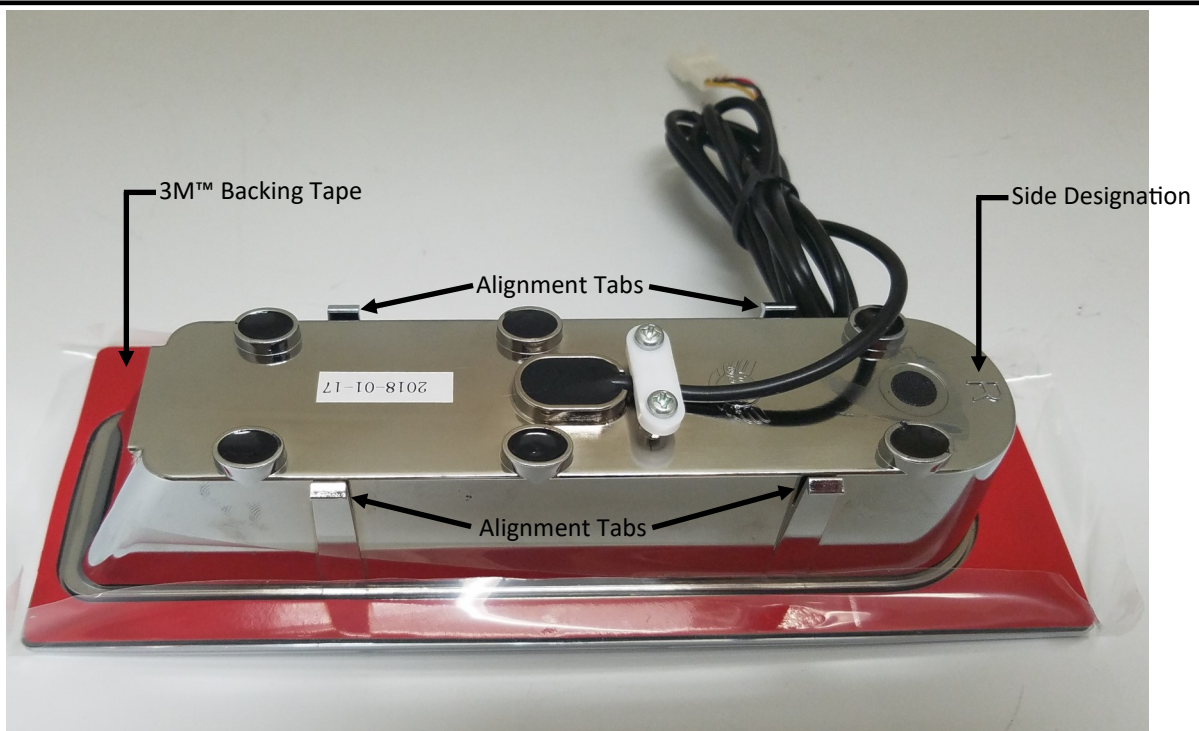
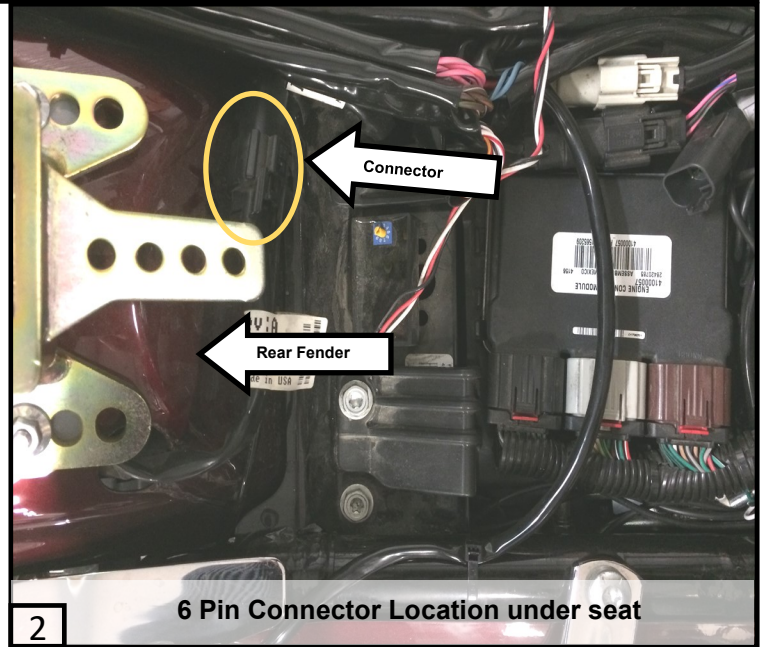

Questions? Call us at: 1 (800) 382-1388 M-TH 8:30AM-5:30PM / FR 9:30AM-5:30PM EST

Installation Instructions - Page 3

MPR-BCM-PLUG Diagram With Fillerz® as Run-Brake and Turn

Be sure the left Fillerz® 3 pin male plug is connected to the MPR-BCM-PLUG adapter's 3 pin female plug with the purple wire and the right Fillerz® 3 pin male plug is connected to the MPR-BCM-PLUG adapter's 3 pin female plug with the brown wire (see below).

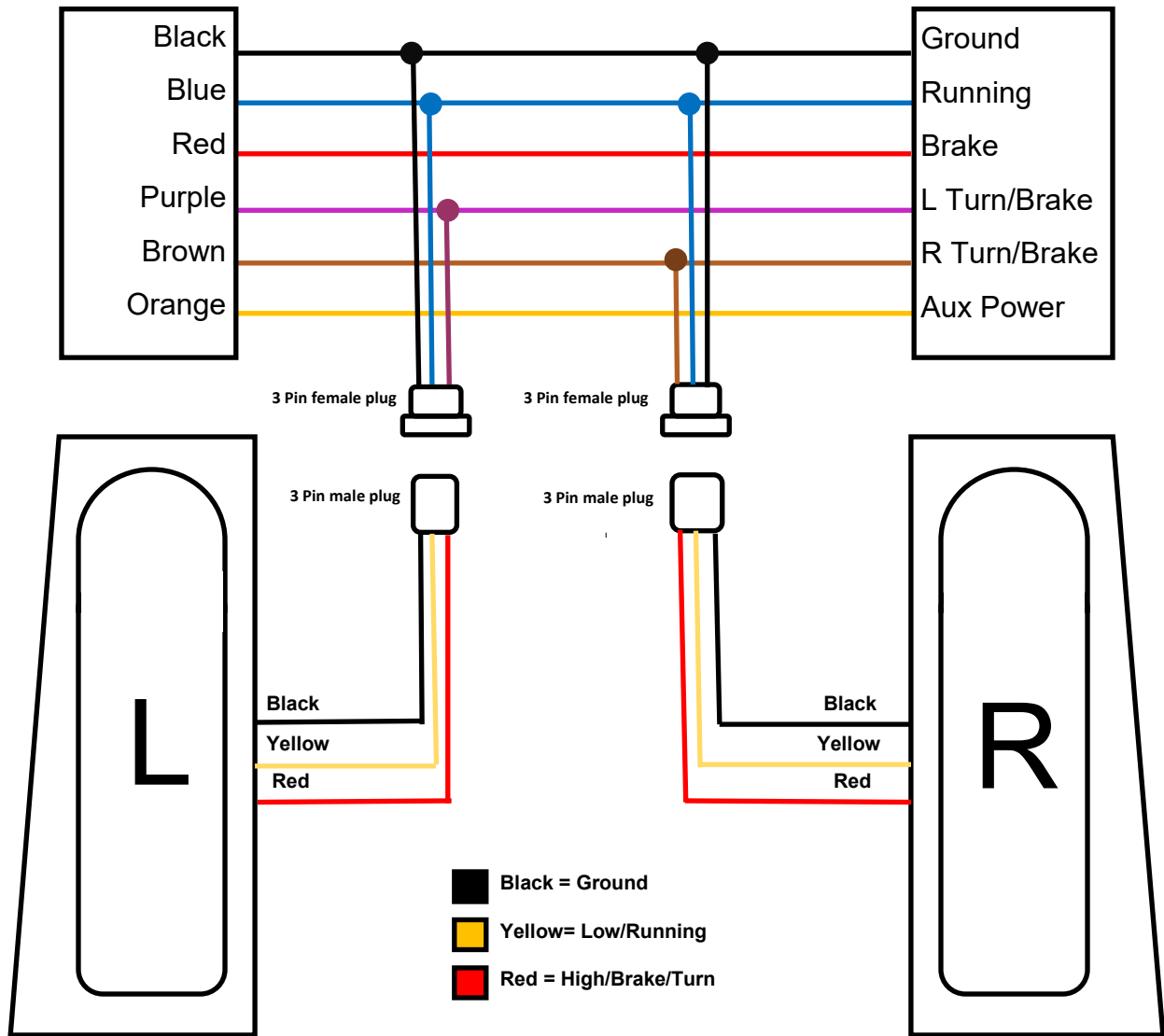

Notice: This product is designed and intended for motorcycle auxiliary lighting use only. This product is **NOT** intended to replace any OEM lighting installed on the motorcycle and should not be used for that purpose. This product must be wired in such a manner that it does not interfere with any OEM lighting.

Installation Instructions - Page 4

Road King

Run-Turn (Original Configuration)

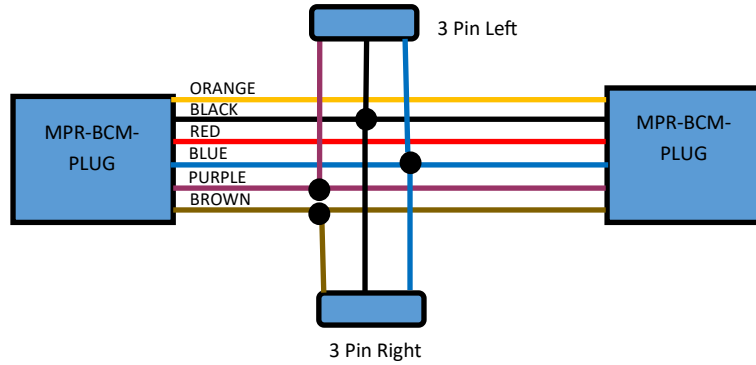

Road King

Run-Brake

*Purple and Brown Wires going from the 3 Pin Connector to the Y Harness must be cut and moved to the red wire of the Y harness.

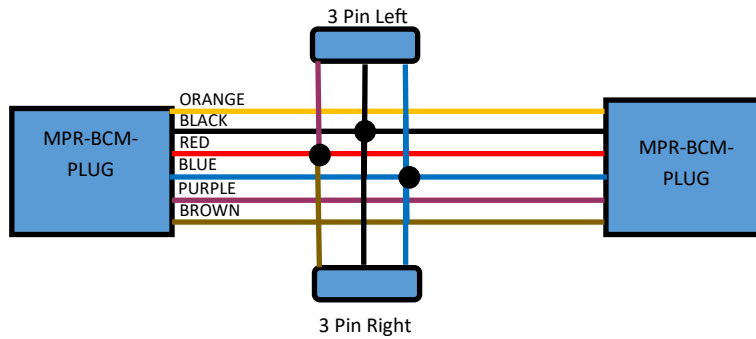

2014-2018 Road King® Standard, 2014-2015 Limited CVO™, & 2015 Road Glide Ultra CVO™

Run-Brake-Turn

*PB-EPZ required for run, brake, turn function (sold separately)

