

Model #: A2000



Owner's Manual and Operating Instructions



2000 lb.



ATV WINCH

Table of Contents

Introduction	1
Accessories.....	1
This Booklet.....	1
Manual Conventions	2
Safety Rules	3
Controls and Features.....	5
Winch.....	5
Installation	6
Step 1-Mount the Winch.....	6
Step 2-Mount the Contactor.....	6
Step 3-Mount the Handlebar Switch	6
Step 4-Mount the Hand Remote Socket (Not Included)	7
Step 5-Wiring the Winch.....	7
Winch Wiring Diagram.....	8
Switch Wiring Diagram.....	9
Operation	10
General Tips for Safe Operation.....	10
Self Recovery	10
Winching Techniques A-Z.....	11
Maintenance	12
Lubrication	12
Cable Assembly Replacement	12
A2000 Specifications	13
Performance Specifications.....	13
<u>Winch Diagram</u>	14
Model: #A2000	14
Winch Parts List	15
Troubleshooting	16
PLOWING ALERT	16
Warranty	17
Warranty Qualifications.....	17
Repair/Replacement Warranty.....	17
Do not return the unit to the place of purchase.....	17
Warranty Exclusions	17
Normal Wear.....	17
Installation, Use and Maintenance	17
Other Exclusions.....	17
Limits of Implied Warranty and Consequential Damage.....	17
Contact Information.....	18
Address.....	18
Corporate	18
Customer Service	18
Technical Service	18
Agreement.....	18
Notes	19

Introduction

Congratulations on your purchase of a KFI winch. KFI researches and develops winches to strict specifications. With proper use and maintenance, this winch will bring years of satisfying service.

This Booklet

Every effort has been made to ensure the accuracy and completeness of the information in this manual. We reserve the right to change, alter and/or improve the product and this document at any time without prior notice.

Accessories

Kappers Fabricating Inc. manufactures, purchases and sells accessories designed to help you get the most from your purchase. To find out more about our products visit our web site at

www.kfiproducts.com

Record the model as well as date and place of purchase for future reference. Have this information available when ordering parts and when making technical or warranty inquiries.

Kappers Fabricating Inc. Support
1-877-346-2050
Model Number
A2000
Date of Purchase
Purchase Location

Manual Conventions

Manual Conventions

This manual uses the following symbols to help differentiate between different kinds of information. The safety symbol is used with a key word to alert you to potential hazards in operating and owning a winch.

Follow all safety messages to avoid or reduce the risk of serious injury or death.

DANGER

DANGER indicates an imminently hazardous situation which, if not avoided, *will* result in death or serious injury.

WARNING

WARNING indicates a potentially hazardous situation which, if not avoided, *could* result in death or serious injury.

CAUTION

CAUTION indicates a potentially hazardous situation which, if not avoided, *may* result in minor or moderate injury.

CAUTION

CAUTION used without the safety alert symbol indicates a potentially hazardous situation which, if not avoided, *may* result in property damage.

NOTE

If you have questions regarding your winch, we can help. Please call our help line at 1-877-346-2050.

Safety Rules

WARNING

Read this manual thoroughly before operating your winch. Failure to follow instructions could result in serious injury or death.

WARNING

Do not exceed the rated capacity.

DANGER

Do not use this winch for lifting or moving people or animals.

DANGER

Keep yourself and others a safe distance to the side of the cable when under tension.

DANGER

Never step over a cable or near a cable under load.

WARNING

The wire rope may break before the motor stalls. For heavy loads at or near rated capacity, use a pulley block/snatch block to reduce the load on the wire rope.

WARNING

Do not move the vehicle to pull a load (towing) on the winch cable. This could result in cable breakage.

WARNING

Pull only on areas of the vehicle as specified by the vehicle manufacturer

WARNING

Do not use the winch to secure or hold a vehicle for a long period of time. Do not use the winch to secure a vehicle for transport.

WARNING

Disconnect the remote control and battery leads when not in use for extended periods.

WARNING

Avoid "shock loads" by using the control switch intermittently to take up the slack in the wire rope. "Shock loads" can far exceed the rate capacity for the wire rope and drum.

Do not accelerate your vehicle while winching. Loss of traction can cause a shock load on the cable. Do not use cable as a pull strap.

Safety Rules

WARNING

Batteries contain acid and produce explosive gases.

Keep sparks, flames and cigarettes away from batteries at all times. Wear safety glasses and protect the eyes at all times. Do not lean over the batteries during operation.

WARNING

When re-spooling the cable, ensure that the cable spools in the under-wind position with the cable entering the drum from the bottom, not the top.

To re-spool correctly, and while wearing gloves, keep a slight load on the cable while pushing the remote button to draw in the cable. Walk toward the winch not allowing the cable to slide through your hands. Do not let your hands get within 12" of the winch while re-spooling. Turn off the winch and repeat the procedure until a few feet of cable is left. Disconnect the remote control and finish spooling by rotating the drum by hand with the clutch disengaged. Keep hands clear of the fairlead and drum while the winch is under power.

WARNING

Do not use as a hoist. Do not use for overhead lifting.

CAUTION

Use gloves to protect hands when handling the cable. Never let the cable slide through your hands.

CAUTION

Do not wrap the cable around any object and hook it back onto itself.

CAUTION

Apply blocks to the wheels of the vehicle when on an incline.

CAUTION

Duration of winching pulls should be kept as short as possible.

If the motor becomes uncomfortably hot to the touch, stop winching immediately and let it cool down for a few minutes. Do not pull for more than one minute at or near the rated load.

CAUTION

If the motor stalls, do not maintain power to the winch.

Electric winches are designed and made for intermittent use and should not be used in constant duty applications.

CAUTION

Never release the free-spool clutch when there is a load on the winch.

CAUTION

Use hook strap when handling the hook for spooling or unspooling the wire rope.

Controls and Features

Read this owner's manual before operating your winch. Familiarize yourself with the location and function of the controls and features. Save this manual for future reference.

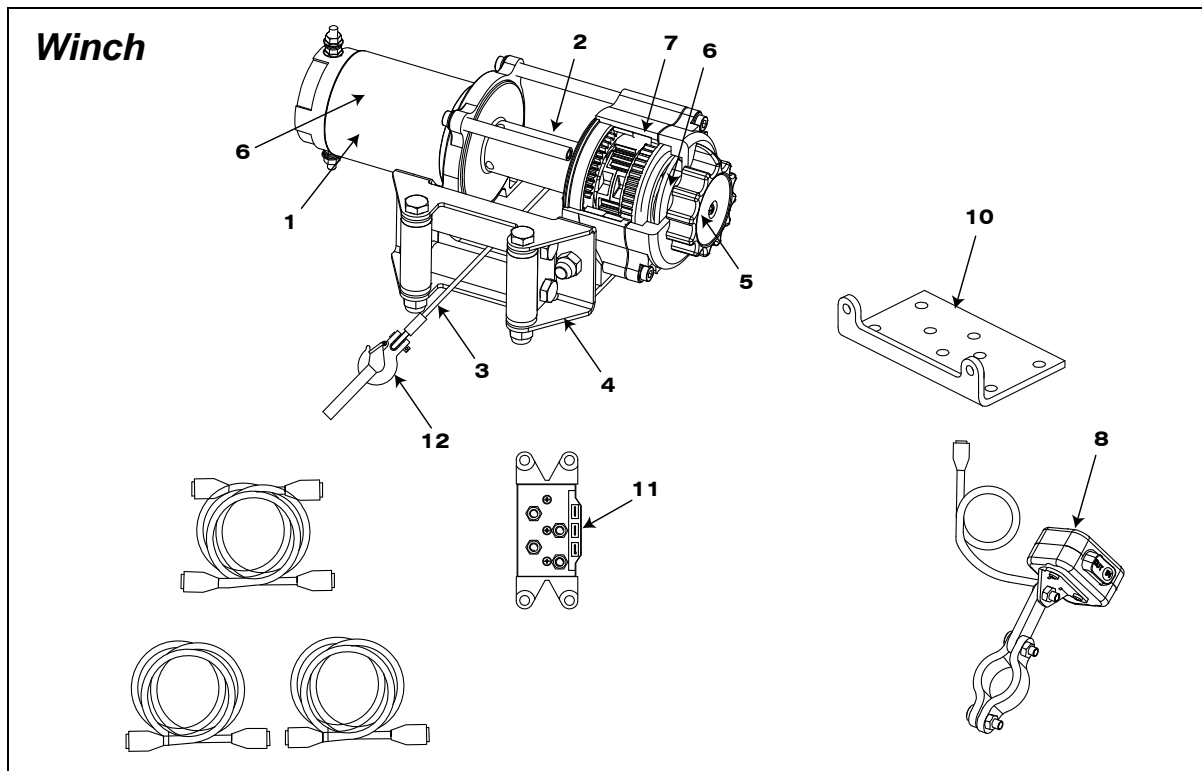

Motor (1): 1.0 HP 12V DC motor provides power to the planetary gear mechanism.

Winch Drum (2): The winch drum is the cylinder on which the wire rope is stored. It can feed or wind the rope depending on the remote winch switch.

Wire Rope (3): 5/32" x 49' galvanized aircraft cable designed specifically for load capacity of 2,000lbs. (47 useable feet with five wraps on the drum). The wire rope feeds onto the drum in the "under wind" position through the roller fairlead (4) and is looped at the end to accept the clevis hook pin (12).

Roller Fairlead (4): When using the winch at an angle the roller fairlead acts to guide the wire rope onto the drum and minimizes damage to the wire rope from abrasion on the winch mount or bumper.

Free spooling Clutch (5): The clutch allows the operator to manually disengage ("FREESPOOL") the spooling drum from the gear train. Engaging the clutch ("ENGAGE") locks the winch into the gear system.

Braking System (6): Braking action is automatically applied to the winch drum when the winch motor is stopped and there is a load on the wire rope.

Planetary Gear System (7): The reduction gears convert the winch motor power into extreme pulling forces. This system allows high torque while maintaining compact size and light weight.

Rocker Switch (8): Rocker switch with handlebar mount for powering the rope in or out of your winch drum.

Fairlead Mount (10): Adapter to mount the winch and fairlead for utility applications.

Contactor (11): Power from the vehicle battery flows through the weather sealed solenoid switch before being directed to the winch motor.

Clevis Hook (12): Provides a means for connecting the looped ends of cables to an anchor.

Installation

Installation

This KFI 2,000 lb winch is designed with a bolt pattern that is standard in this class of winch. Many winch mounting kits are available that utilize this bolt pattern for the most popular ATV's and UTV's. You can find most of the ATV/UTV winch mounts on our Website www.kfiproducts.com

Step 1-Mount the Winch

WARNING

Before you start to install this winch, disconnect the vehicle ground and positive leads from the battery.

1. Install the winch and fairlead with the supplied hardware per the instructions provided with the model specific mounting kit or prepare a flat, secure mounting location for the winch.

NOTE

If you choose not to use a model specific mounting kit, you will need to drill holes in the structural support of the vehicle. Be certain that your structural support will stand up to the pulling forces of this winch.

CAUTION

Mounting bolts must be SAE grade 5 or better and torque to 17 ft. lbs.

2. Attach the winch using the M8 x 25 bolts and washers through the fairlead bracket or model specific mount and then into the winch.
3. Disengage the clutch by rotating the clutch cap to the "FREESPOOL" position. Release the wire rope and pull through the roller fairlead.
4. Attach the clevis hook and hand strap to the cable.

Step 2-Mount the Contactor

1. Find a location for the contactor. If the Model specific mounting kit does not indicate a recommended contactor location, then it is recommended that the contactor be mounted close to the battery in a clean dry location. Make sure the location you chose allows sufficient clearance from all metal components. Drill mounting holes if required. Once location is found do not install until all wiring is completed.

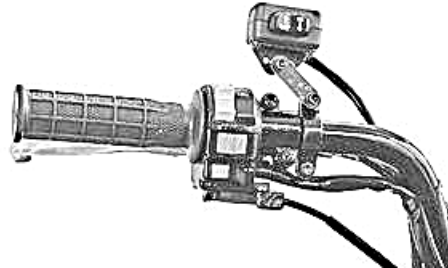

Step 3-Mount the Handlebar Switch

1. The switch is usually installed on the left handlebar.
2. Use a piece of electrical tape around the handlebar to help prevent rotation of the mount on the handlebar. Do NOT tighten over any hoses or cables.
3. Once your switch is mounted you can route the wires back to where your contactor is located.
4. Splice the end of the red wire to an ignition (keyed) controlled power source using the supplied wire splice. You may need to use a test light to locate a suitable wire. The wire should only have power when the key is in the ON position.
5. Make sure the handlebars have full range of motion and then secure the switch's cable with the supplied cable ties.

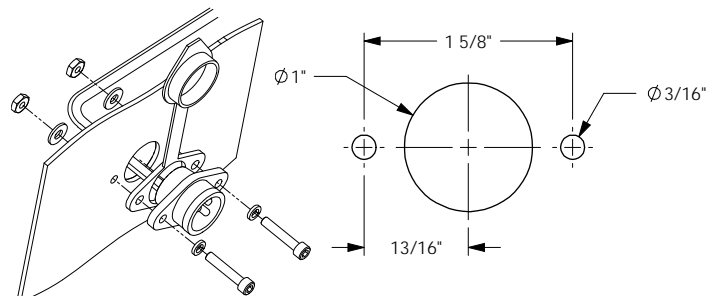

Not to scale. Do NOT use as a template

Installation

Step 4-Mount the Hand Remote Socket (Not Included)

1. Determine a mounting location for the hand remote socket. Make sure the area behind your selected location is clear.
2. Drill the three holes as shown in the figure on page 6 and install using the supplied hardware. You can use the rubber cap as a template.
3. Once your remote socket is mounted you can route the wires back to where your contactor is located.
4. Splice the end of the red wire to an ignition (keyed) controlled power source using the supplied wire splice. You may need to use a test light to locate a suitable wire. The wire should only have power when the key is in the ON position.
5. Secure the cable with the supplied cable ties

Step 5-Wiring the Winch

CAUTION

Never route electrical cables across any sharp edges, through or near moving parts, or near parts that become hot

CAUTION

When attaching wires to the motor or contactor terminals, hold the inner nut with a wrench while tightening the outer nut with a second wrench. Do **NOT** allow the terminals to rotate in their housings. Rotation may cause internal wire breakage or grounding. See Proper Terminal Tightening Figure.

NOTE

Depending on the location of the contactor, you may need to use the black and red cables in place of the yellow and blue, and the yellow and blue in place of the red and black. Just remember that this also changes the diagram.

1. Connect the yellow and blue cables to the motor terminals on the winch. Note caution above. Route the other ends to the contactor location. (See diagram on page 8)
2. Connect the yellow and blue cables to the contactor (yellow to yellow and blue to blue). Do NOT tighten nuts. (See diagram on page 8)

3. Connect the red and black cables to your contactor (red to red and black to black). Do NOT tighten nuts. Route the other ends to your battery location. (See diagram on page 8)
4. Connect the Handle bar switch to the contactor. (black to black and green to green) (See diagram on page 9)

NOTE

If you are installing the remote socket along with the handlebar switch you will need to connect the remote socket to the contactor and then the handlebar switch to the remote socket. (See diagram on page 9)

5. Once all wiring is connected to the contactor you can then mount it using the supplied M6 hardware.
6. Torque the contactor terminal nuts to 4.5 N-m (40 lb-in). Do NOT over tighten.
7. Place all terminal boots over terminals and secure all cables with zip ties or electrical tape.
8. Connect the battery leads from the contactor to the ATV's Battery (red to red and black to black) (See diagram on page 8)

CAUTION

Battery cables should not be drawn taut. Leave some slack for cable movement.

9. Check for proper drum rotation. Turn the clutch cap to the "FREESPOOL" position. Pull out some cable from the drum, and then turn the clutch cap to the "ENGAGE" position to engage the gears. Make sure your machine is running and press the cable out button on the switch. If the drum is turning and releasing more cable, then your connections are accurate. If the drum is turning and collecting more cable, then reverse the leads on the motor. Repeat and check rotation.

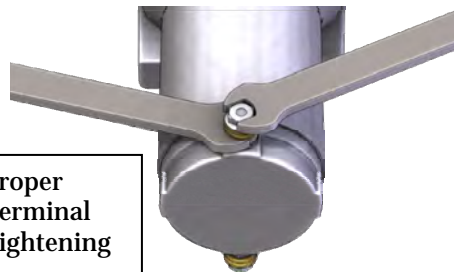

Installation

Winch Wiring Diagram

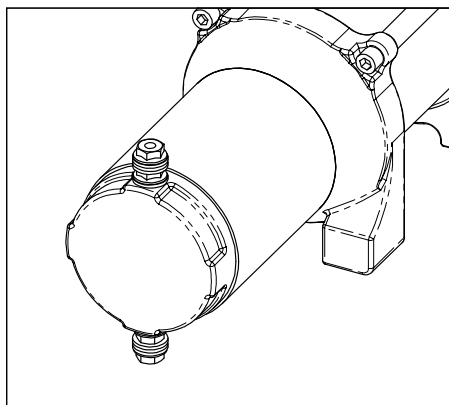
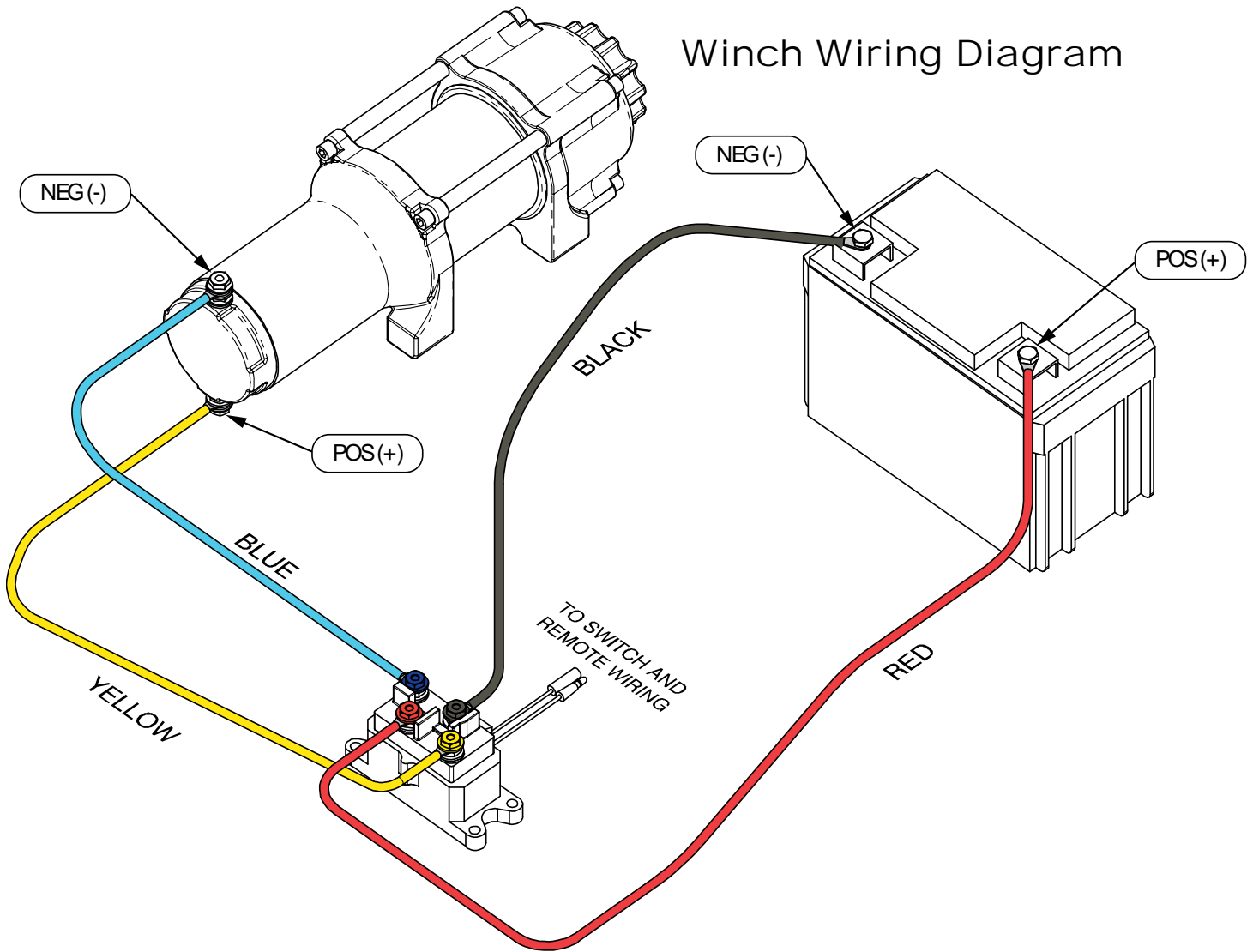

LEADS AT DEFAULT POSITION

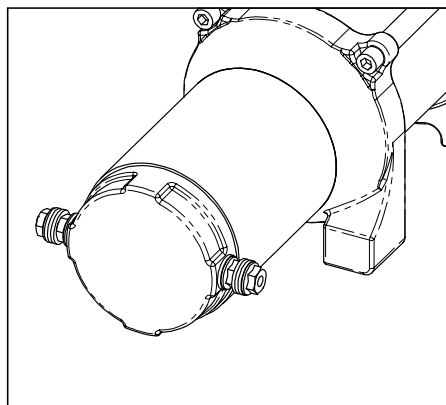
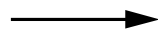

LEADS ROTATED 90°

With some applications the motor leads may need to be rotated to avoid interference with other components. If rotation is required please give us a call at 1-877-346-2050 for instructions or visit our website at www.kfiproducts.com and look in the Instructions section.

Installation

Switch Wiring Diagram

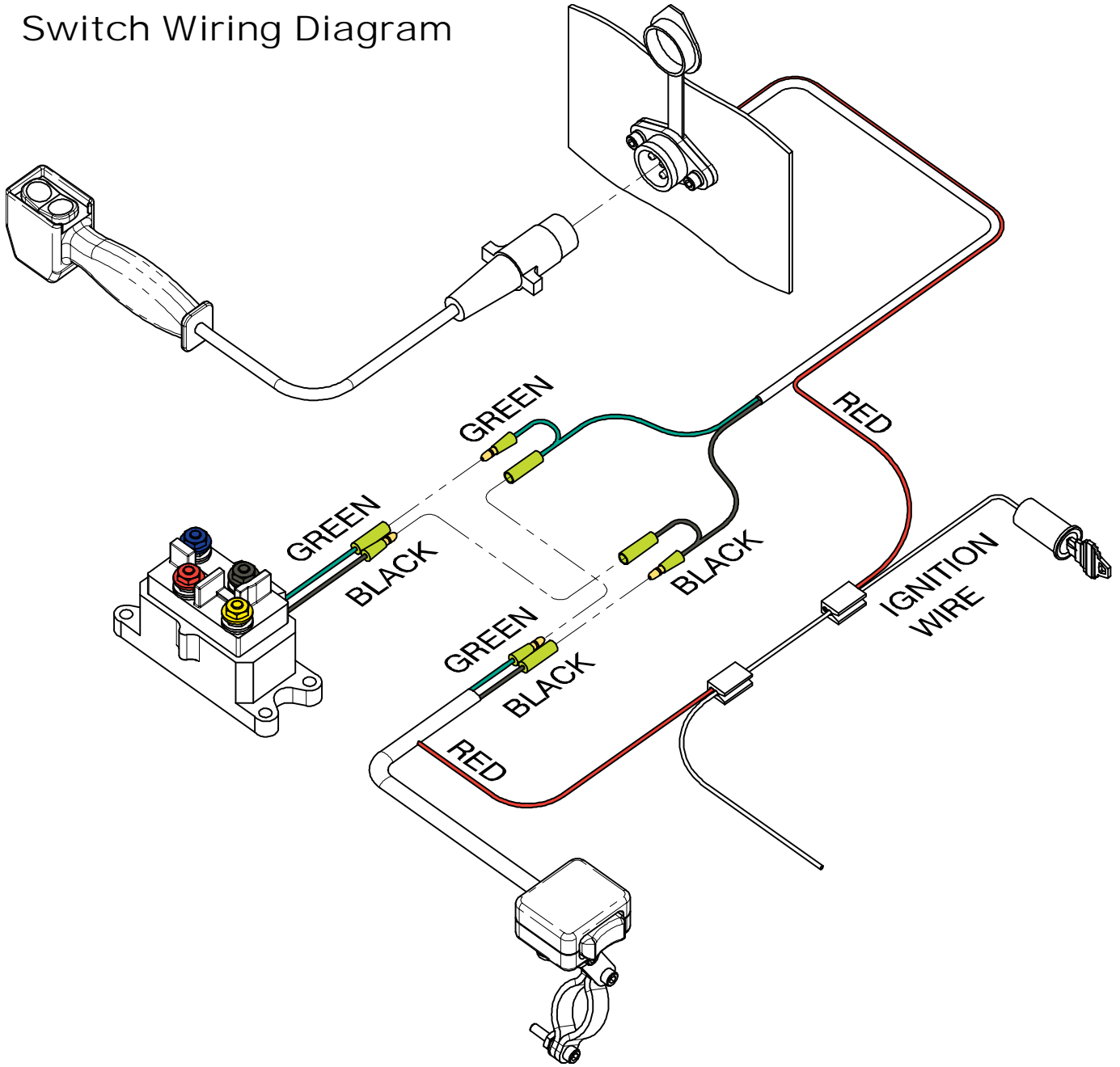

Operation

Operation

General Tips for Safe Operation

Your A2000 winch is rated at 2,000 lbs. capacity in first layer (max) when spooling the first rope layer on the drum. Overloads can damage the winch, motor and/or wire rope. For loads over 1,300 lbs. we recommend the use of the pulley block/snatch block to double the wire rope line. This will aid in two ways:

- reduce the number or rope layers on the drum, as well as,
- reduce the load on the wire rope by as much as 50%.

When doubling the line back to the vehicle, attach to the tow hook, frame or other load bearing part.

The vehicle engine should be kept running during operation of the winch to minimize battery drain and maximize power and speed of the winch. If the winch is used for a considerable time with the engine off the battery may be drained and too weak to restart the engine.

Get to know your winch before you actually need to use it. We recommend that you set up a few test runs to familiarize yourself with rigging techniques, the sounds your winch makes under various loads, the way the cable spools on the drum, etc.

Inspect the wire rope and equipment before each use. A frayed or damaged rope should be replaced immediately. Use only manufacturer's identical replacement rope with the exact specifications.

Inspect the winch installation and bolts to ensure that all bolts are tight before each operation.

Store the remote control inside your vehicle in a place that it will not be damaged.

Any winch that appears to be damaged in any way, is found to be worn, or operates abnormally **MUST BE REMOVED FROM SERVICE UNTIL REPAIRED**. It is recommended that the necessary repairs be made by a manufacturer's authorized repair facility.

Pull only on areas of the vehicle as specified by the vehicle manufacturer.

Only attachments and/or adapters supplied by the manufacturer are to be used.

Self Recovery

Locate a suitable anchor such as a strong tree trunk or boulder. Always use a sling as an anchor point.

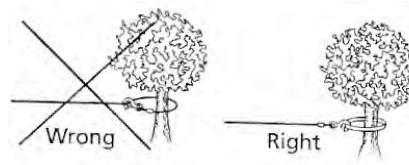

Your winch is equipped with a roller fairlead to help guide the wire rope and to reduce binding on short side pulls.

Do not winch from an acute angle as the wire rope will pile up on one side of the drum causing damage to wire rope and the winch.

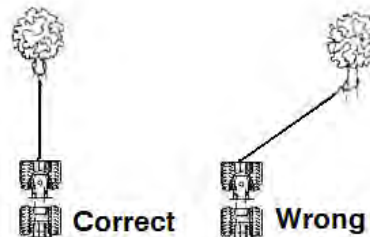

Short pulls from an angle can be used to straighten the vehicle. Long pulls should be done with the wire rope at a 90° angle to the winch/vehicle.

When pulling a heavy load, place a winch saver, blanket or jacket over the wire rope five or six feet from the hook.

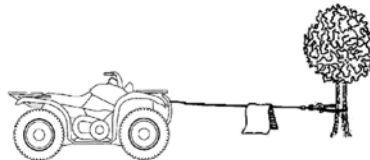

In the event of a broken cable it will dampen the snap back. For additional protection open the hood of the vehicle.

For pulls over 1,300lbs., we recommend the use of the snatch block/pulley block to double line the wire rope.

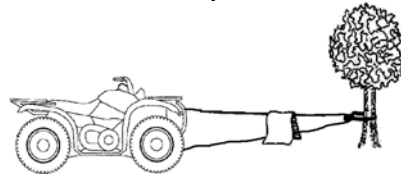

This reduces the load on the winch and the strain on the rope by approximately 50%

Winching Techniques A-Z

- a. Take time to assess your situation and plan your pull.
- b. Put on gloves to protect your hands.
- c. Disengage the clutch to allow free-spooling and also save battery power.
- d. Attach the hook strap to the clevis hook.
- e. Pull out the wire rope to your desired anchor point using the hook strap.
- f. Secure the clevis hook to the anchor point: Sling, chain or snatch block. Do not attach the hook back onto the wire rope.
- g. Engage the clutch.
- h. Start your engine to ensure power is being replenished to the battery.
- i. Power in the wire rope guiding the wire under tension to draw up the slack in the wire. Once the wire is under tension, stand clear. Never step over the wire rope.
- j. Double check your anchors and make sure all connections are secure.
- k. Inspect the wire rope. Make sure there are at least 5 wraps of wire rope around the winch drum.
- l. Drape a blanket or jacket over the wire rope approximately 5 to 6 feet from the hook.
- m. Clear the area. Make sure all spectators stand clear and that no one is directly in front or behind the vehicle or anchor point.
- n. Begin winching. Be sure that the wire rope is winding evenly and tightly around the drum. The vehicle that is being winched can be slowly driven to add assistance to the winching process. Avoid shock loads; keep the wire rope under tension.
- o. The vehicle to be winched should be placed in neutral and the parking brake released. Only release the brake pedal when under full tension. Avoid shock loads to the winch. This can damage the winch, rope and vehicle.
- p. The winch is meant for intermittent use. Under full load with a single line rig do not power in for more than a minute without letting the motor cool down for a few minutes and then resume the winching operation.
- q. The winching operation is complete once the vehicle is on stable ground and is able to drive under its own power.
- r. Secure the vehicle. Be sure to set the brakes and place the vehicle in park.
- s. Release the tension on the wire rope. The winch is not meant to hold the vehicle for long periods of time.
- t. Disconnect the wire rope from the anchor.
- u. Rewind the wire rope. Make sure that any wire already on the drum has spooled tightly and neatly. If not, draw out the wire and re-spool from the point where the rope is tight.
- v. Keep your hands clear of the winch drum and fairlead as the wire rope is being drawn in.
- w. Secure the hook and hook strap.
- x. Disconnect the remote control and store in a clean, dry place.
- y. Clean and inspect connections and mounting hardware for next winching operation.
- z. Never use the winch as a tie down.

Maintenance

Maintenance

The owner/operator is responsible for all periodic maintenance.

WARNING

Never operate a damaged or defective winch.

WARNING

Improper maintenance will void your warranty.

Complete all scheduled maintenance in a timely manner. Correct any issue before operating the winch.

NOTE

For service or parts assistance, contact our help line at 1-877-346-2050.

Lubrication

All moving parts within the Electric Winch have been Lubricated using high temperature lithium grease at the factory. No internal lubrication is required under normal conditions. If the winch is subjected to extreme conditions lubrication may be required using a high temperature lithium grease. Lubricate Cable Assembly (4) periodically using a light penetrating oil.

Cable Assembly Replacement

It is recommended that any modifications be performed by a manufacturer's authorized repair facility, and that only manufacturer-supplied parts be used

1. Rotate the clutch cap to the "Free Spool" position.
2. Extend Cable Assembly to its full length. Note how the existing cable is connected to the inside of the drum.
3. Remove old Cable Assembly and attach new one.
4. Rotate the clutch cap to the "Engage" position.
5. Retract Cable Assembly onto drum being careful not to allow kinking or over heating of the winch.

A2000 Specifications

Performance Specifications

Rated Pull	2,000Lbs (907 kg)
Gear Reduction Ratio	171:1
Motor	Permanent Magnet 1.0 HP (DC 12V)
Duty Cycle	Intermittent use only
Drum Size	1.5 in. (D) x 3.15 in. (L) 38 mm (D) x 80 mm (L)
Cable	5/32 in. (D) x 49 ft. (L) 4 mm (D) x 15 m (L)
Weight	24.3 lbs. (11 kg) complete kit
Height	4.2 inches (107 mm)
Width	4.06 inches (103mm)
Length	12.28 inches (312 mm)
Bolt Pattern	4-7/8" x 3" (124mm x 76 mm)

Line speed and Motor Current (First layer)						
Line pull Max	lbs	0	500	1000	1500	2000
	kgs	0	227	454	680	907
Line speed (12VDC)	FPM	9.84	8.20	6.65	5.58	4.27
	MPM	3.0	2.5	2.0	1.7	1.3
Max Current	amps	15	40	65	100	140
Cooling Time	minutes	5	5	5	5	5
Running Time	minutes	1	1	1	1	1

Line pull and cable capacity						
Layers of cable on drum		1	2	3	4	5
Max pulling capacity per layer	lbs	2000	1630	1380	1190	1050
	kgs	907	739	626	540	476
Cable capacity per layer	ft	8	17	27.6	39.4	49
	m	2.4	5.2	8.4	12	15

* Use double line and snatch block for pulling loads over 1,800lbs / 816.48kgs.

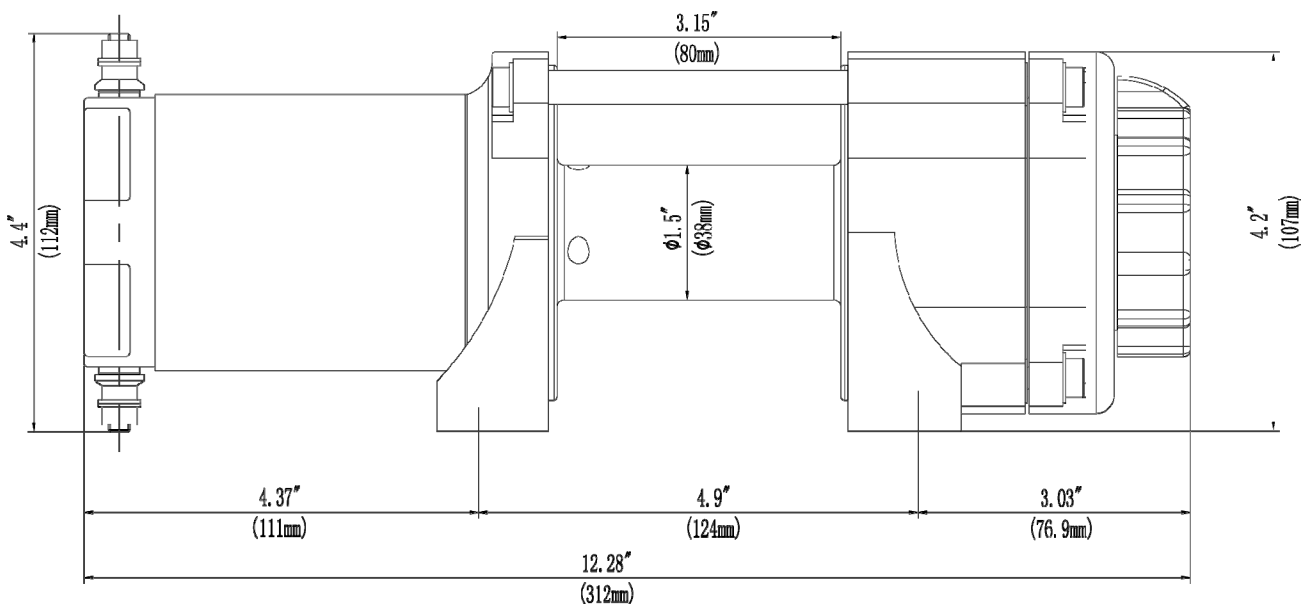

A2000 Specifications

Winch Diagram

Model: #A2000

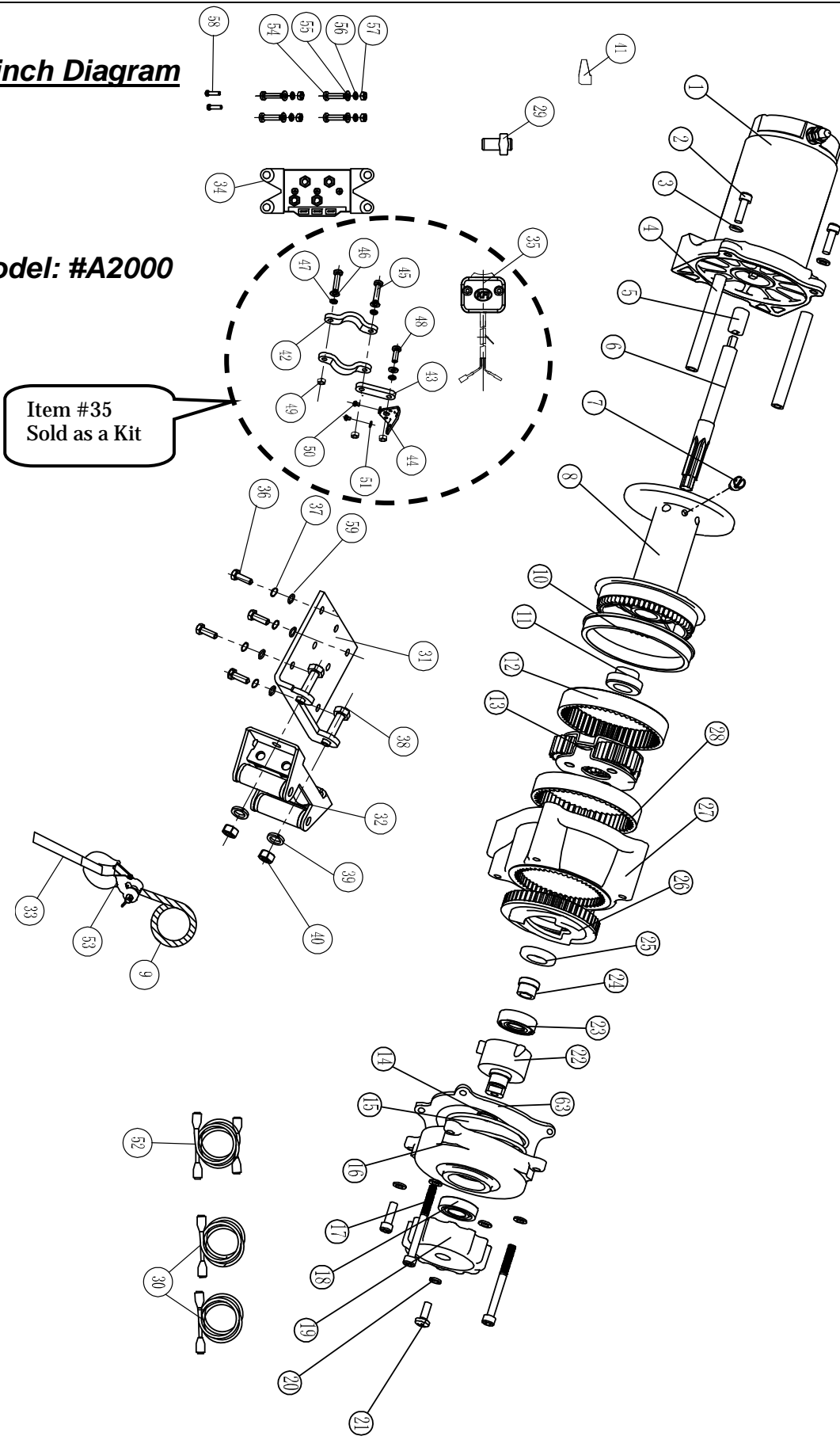

A2000 Specifications

Winch Parts List

No.	Part #	Description	Qty
1	200100-C	Motor Assembly	1
2	200001	Screw M6 x 20	4
3	200002	Washer -Flat $\Phi 6$	6
4	200003	Tie Bar	2
5	200004	Bushing Shaft	1
6	200005	Coupling Shaft	1
7	200006	Screw M5 x 8	1
8	200007	Drum	1
9	ATV-CBL-2K	2K CABLE 5/32" X 49'	1
10	200008	Rear Bush Drum	1
11	200009	Front Thrust Washer	1
12	200010	Gear Ring Output	1
13	250300	Gear Carrier Assembly	1
14	200011	Retaining Ring Clip	1
15	200012	Spring	1
16	200013	Cover Clutch Housing	1
17	200014	Cap Screw M6 x 70	2
18	GB2760BB160 02-SS	Radial Ball Bearing 16002 Sealed	1
19	200016	Clutch Cap	1
20	200017	Locking Washer $\Phi 6$	1
21	200018	Cap Screw M6 x 16	1
22	200019	Axis Support Bushing	1
23	GB2760BB060 02-SS	Radial Ball Bearing 6002 Sealed	1
24	200021	Clutch Bushing	1
25	200022	Above Clutch Axis Washer	1
26	200023	Cam Clutch Gear	1
27	200024	Gear Housing / End Bearing	1
28	200025	Gear Ring	1
29	200062	Wire Tap	1
30	A-WIRES-WIN	Winch Wires	2
31	100495	Standard Roller Fairlead Bracket	1
32	ATV-RF	Roller Fairlead	1
33	200030	Hand Saver Strap	1
34	ATV-CONT	Contactora	1
35	ATV-MR	Mini Rocker Switch	1
36	200032	Hex Hd Bolt M8 x 25	4
37	200063	Locking Washer $\Phi 8$	4
38	200033	Screw M10 x 20	2
39	200035	Locking Washer $\Phi 10$	2
40	200036	Nut M10	2
41	200061	Terminal Protector	8
42	200045	Handlebar Switch Clamp	2
43	200046	Handlebar Switch Extender	1

No.	Part #	Description	Qty
44	200047	Handlebar Switch Mounting Angle	1
45	200048	Screw M5 x 25	2
46	200049	Washer -Flat $\Phi 5$	3
47	200050	Locking Washer $\Phi 5$	3
48	200051	Screw M5 x 18	1
49	200052	Nut M5	3
50	200053	Screw #6-32 x 9/32"	2
51	200054	Locking Washer #6	2
52	A-WIRES-BAT	Battery Wires	2
53	SE-HOOK	Clevis Hook - Black E-Coat	1
54	200065	Screw M6 x 25	4
55	200066	Washer -Flat $\Phi 6$	4
56	200067	Locking Washer $\Phi 6$	4
57	200068	Nut M6	4
58	200069	Screw M6 x 1.0 x 20	2
59	200070	Washer -Flat $\Phi 8$	4
63	200072	Gasket	1

Troubleshooting

Troubleshooting

Problem	Cause	Solution
Motor does not turn on	Switch Assembly not connected properly	Insert Switch Assembly all the way into the connector.
	Loose battery cable connections	Tighten nuts on all cable connections.
	Contactors malfunctioning	Tap Contactors to loosen contacts. Apply 12 volts to coil terminals directly. A clicking indicates proper activation.
	Defective Switch Assembly	Replace Switch Assembly.
	Broken Motor Leads. Over tightened leads and broke internal wire connection. May have also broken Isolator	Pull End-Cap off and check terminal solder joint and plastic isolator. Get a replacement End-Cap #A-CAPKIT
	Defective motor	Check for voltage at armature port with Switch pressed. If voltage is present, Replace motor.
	Water has entered motor	Allow to drain and dry. Run in short bursts without load until completely dry.
Motor runs but Cable drum does not turn	Clutch not engaged	Rotate clutch cap to the "Engage" position. If problem persists, a qualified technician needs to check and repair.
Motor runs slowly or without normal power	Insufficient current or voltage	The battery is weak, recharge. Run winch with vehicle motor running (Battery should have a strong charge)
	Loose or corroded battery cable connections.	Clean, Tighten, or replace.
	Worn Brushes	Replace Worn Brushes
Motor overheating	winch running time too long	Allow winch to cool down periodically.
Motor runs in one direction only	Defective or stuck Contactors	Tap Contactors to loosen contacts.
		Repair or Replace Contactors.
	Over tightened leads and broke internal wire connection. May have also broken Isolator.	Pull End-Cap off and check terminal solder joint and plastic isolator. Get a replacement End-Cap #A-CAPKIT
	Defective Wire Crimp or Bad connection	Check all connections
	Defective Switch Assembly	Replace Switch Assembly.

WARNING

PLOWING ALERT

READ BEFORE USING YOUR WINCH TO LIFT A PLOW

ATV winches are one of the most widely used methods of lifting a plow. When used properly they are a perfect match to any plow system but proper precautions and correct usage are required to prevent costly damage.

When lifting a plow using a winch it is very important to stop the plow before its full lift height is reached. Failure to do so will cause the winch to pull against itself and can, and most likely will, cause damage to the winch, your plow frame and your ATV.

Please remember that winch damage such as stripped gears, broken housings and bent and damaged parts caused by exceeding your plows lift height are not covered by warranty. Special precautions should be taken when backing up or other instances where you may be distracted and forget your finger is still on the power-in switch.

A little practice and common sense will ensure a trouble free plow season and prolong the life of your equipment.

Warranty

KAPPERS FABRICATING INC.
ONE YEAR LIMITED WARRANTY

Effective July 1, 2016

Warranty Qualifications

Kappers Fabricating Inc. (KFI) will register this warranty upon receipt of your Warranty Registration Card and a copy of your sales receipt from one of KFI's resale locations as proof of purchase.

Please submit your warranty registration and your proof of purchase within Fifteen (15) days of the date of purchase.

Repair/Replacement Warranty

KFI warrants to the original purchaser that the mechanical and electrical components will be free of defects in material and workmanship for a period of one (1) year from the original date of purchase (90 days for commercial & industrial use).

Transportation charges on product submitted for repair or replacement under this warranty are the sole responsibility of the purchaser. This warranty only applies to the original purchaser and is not transferable.

Do not return the unit to the place of purchase

Contact KFI's Technical Service and KFI will troubleshoot any issue via phone or e-mail. If the problem is not corrected by this method, KFI will, at its option, authorize evaluation, repair or replacement of the defective part or component at a KFI Service Center. KFI will provide you with a case number for warranty service. Please keep it for future reference. Repairs or replacements without prior authorization, or at an unauthorized repair facility, will not be covered by this warranty.

Warranty Exclusions

This warranty does not cover the following repairs and equipment:

Normal Wear

Winches need periodic parts and service to perform well. This warranty does not cover repair when normal use has exhausted the life of a part or the equipment as a whole.

Installation, Use and Maintenance

This warranty will not apply to parts and/or labor if this winch is deemed to have been misused, neglected, involved in an accident, abused, loaded beyond the winch's limits, modified, installed improperly or connected incorrectly to any electrical component. Normal maintenance is not covered by this warranty.

Other Exclusions

This warranty excludes:

- The winch cable.
- Cosmetic defects such as paint, decals, etc.
- Accessory parts such as storage covers.
- Failures due to acts of God and other force majeure events beyond the manufacturer's control.
- Problems caused by parts that are not original Kappers Fabricating Inc.
- Cable Stacking and Water Submersion

Limits of Implied Warranty and Consequential Damage

Kappers Fabricating Inc. disclaims any obligation to cover any loss of time, use of this product, freight, or any incidental or consequential claim by anyone from using this winch. THIS WARRANTY IS IN LIEU OF ALL OTHER WARRANTIES, EXPRESS OR IMPLIED, INCLUDING WARRANTIES OF MERCHANTABILITY OR FITNESS FOR A PARTICULAR PURPOSE

A unit provided as an exchange will be subject to the warranty of the original unit. The length of the warranty governing the exchanged unit will remain calculated by reference to the purchase date of the original unit.

This warranty gives you certain legal rights which may change from state to state. Your state may also have other rights you may be entitled to that are not listed within this warranty.

Warranty

Contact Information

Address

KFI Products
Winch Customer Service
P.O. Box 32
721 Sata Drive
Spring Valley, MN 55975

Corporate

Kappers Fabricating Inc.
1015 Industrial Dr.
P.O. Box 32
Spring Valley, MN 55975

Customer Service

Mon – Thur 8:00 AM – 5:00 PM (CST/CDT)
Fri 8:00 AM – 1:00 PM (CST/CDT)
Toll Free: 1-877-346-2050
Fax no.: 1-507-346-2010
sales@kfiproductions.com

Technical Service

Mon – Thur 7:00 AM – 5:00 PM (CST/CDT)
Fri 7:00 AM – 2:30 PM (CST/CDT)
Toll Free: 1-877-346-2050
tech@kfiproductions.com

Agreement

By purchasing and/or using any item from KFI and/or its parent company, the purchaser acknowledges to be at least 18 years of age. Purchaser also acknowledges that winch products are inherently dangerous and hazardous, and that use of the product involves the risk and danger of serious bodily injury including, but not limited to, disability, paralysis, dismemberment and death. Additional risks may exist that may not be readily foreseeable.

Purchaser agrees to comply with all applicable laws governing the use of the product, and to observe all appropriate safety precautions, including the wearing of appropriate protective gear and clothing, and operating the product safely and under safe conditions.

Purchaser fully accepts and assumes responsibility for all such risks, losses, costs, and damages incurred as a result of the use of the product, whether by purchaser or anyone using the product with or without purchaser's permission.

Your purchase of the product shall constitute your release and indemnity in favor of KFI and/or its parent company, its shareholders, officers, directors and employees from any and all claims or injuries of every kind resulting from use or operation of the product, including costs and attorney's fees incurred in connection therewith.

Notes



1-877-346-2050

**KFI Products
P.O. Box 32
721 Sata Drive
Spring Valley, MN 55975
www.kfiproducts.com
Made in China
©2012 Kappers Fabricating Inc.**

**Corporate Office:
Kappers Fabricating Inc.
P.O. Box 32
1015 Industrial Drive
Spring Valley, MN 55975 USA**