

“2000-07” Honda Rancher Mount

Winch Mount

PART # 100505

Kit Components:

Qty	Part Description
1.....	Winch Mount
1.....	Support Bracket
4.....	1/4"-20 x 1" x 1-1/2 " U-Bolt
8.....	1/4" Nylock Nuts
8.....	1/4" Flat Washers
2.....	5/16"-18 X 1" Hex Flange Bolt
2.....	5/16"-18 Nylock Nut
2.....	5/16" SAE Flat Washer
2.....	M8-1.25 x 25mm HH Bolt

INSTALLATION INSTRUCTIONS:

1. Begin by removing and discarding the 8mm bolts [A] on both sides located inside the front wheel well "Figure 1"
2. Place mount and support bracket into location as shown in "Figure 1" and assemble supplied 8mm Bolts [A], U-bolts and 5/16" hardware [D] but do not tighten. Due to frame shifting after removing bolts from step 1 it may be a little tricky to get these bolts back in. You may need to loosen all front bumper bolts to get the frame holes to line up better.
3. Assemble supplied U-bolts [B]. You may need to put the U-bolts on over the tubing where it is bent towards the top and then slide them down to location. "Figure 2"
4. You may now tighten all hardware. "Figure 1&2"
5. Assemble hawse or roller fairlead and winch to winch mount using hardware that was supplied with your winch and fairlead.
6. With most winches you will need to remove the headlight cap [C] for clearance shown in "Figure 3"
7. Using the instructions provided with your winch, wire accordingly.

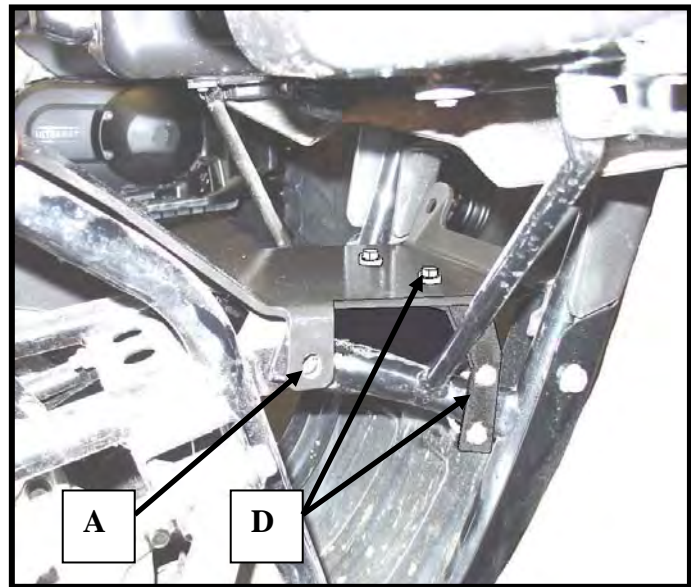

Figure 1 Remove 8mm bolts

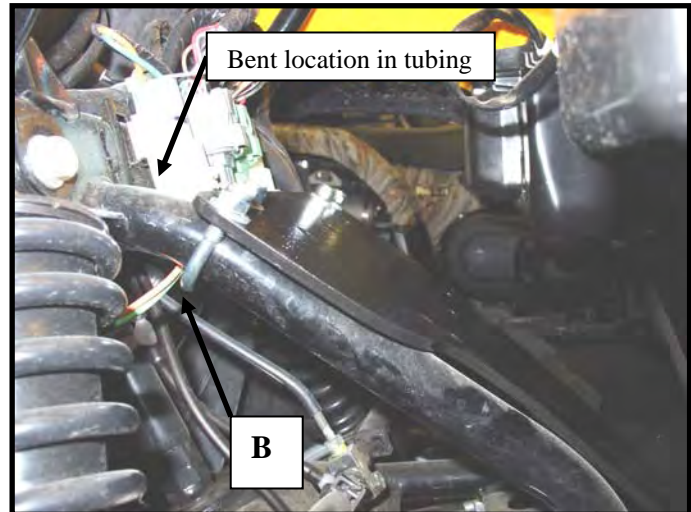

Figure 2 Assemble U-bolts

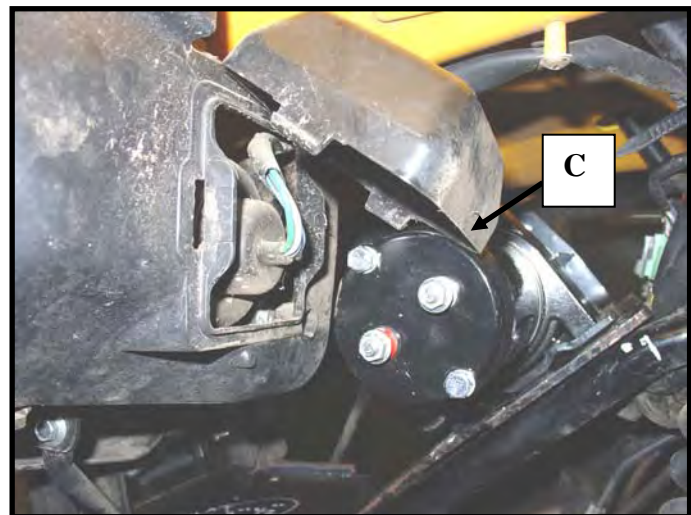

Figure 3 Remove Headlight rear cap

Suggested Contactor Location

- Figures 4 and 5 show Location of a suggested position of the contactor that comes with your winch. This location is on the RH side of the ATV, mounted to the side of the storage box. Mounting the contactor in this location will require drilling two holes in the side of the storage box.

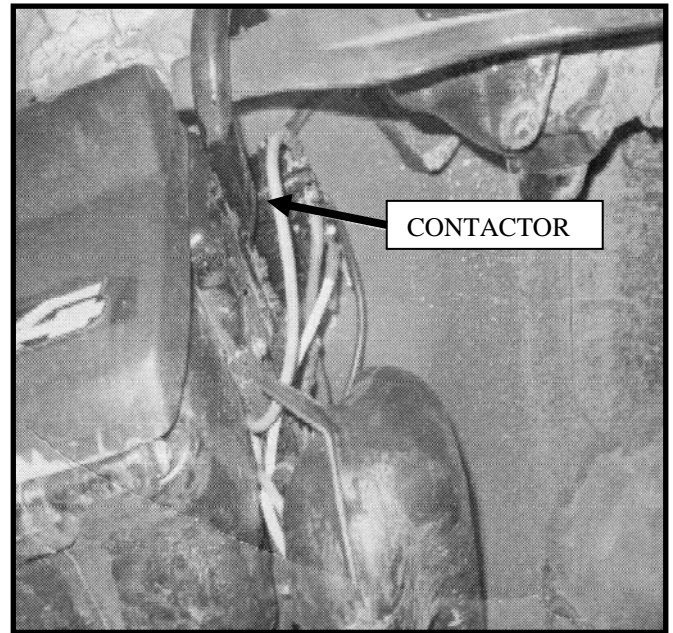
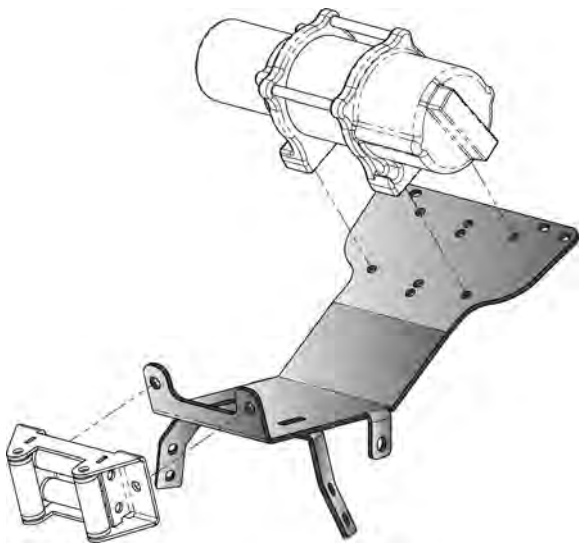
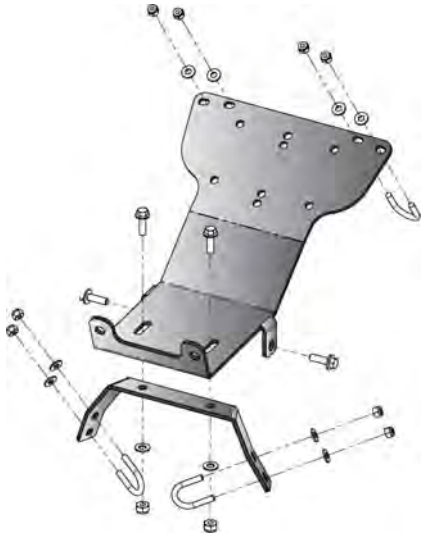

Figure 4 Contactor Location

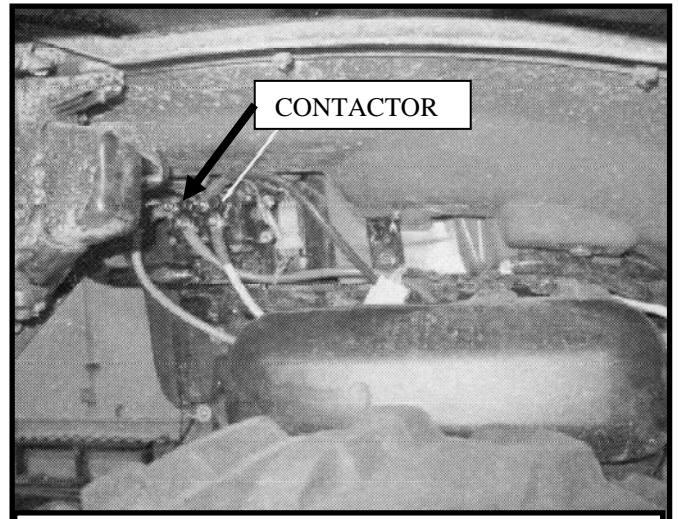

Figure 5 Contactor Location

