

FLARE® FOR INDIAN® CHALLENGER & PURSUIT

INCLUDED COMPONENTS:

- (1) Flare® Windshield
- (1) Instruction Sheet

TOOLS REQUIRED:

- + 4 mm Hex Key Socket
- + Torque Wrench

QUESTIONS?



EMAIL:
info@getklocked.com
CALL: (605) 996.3700

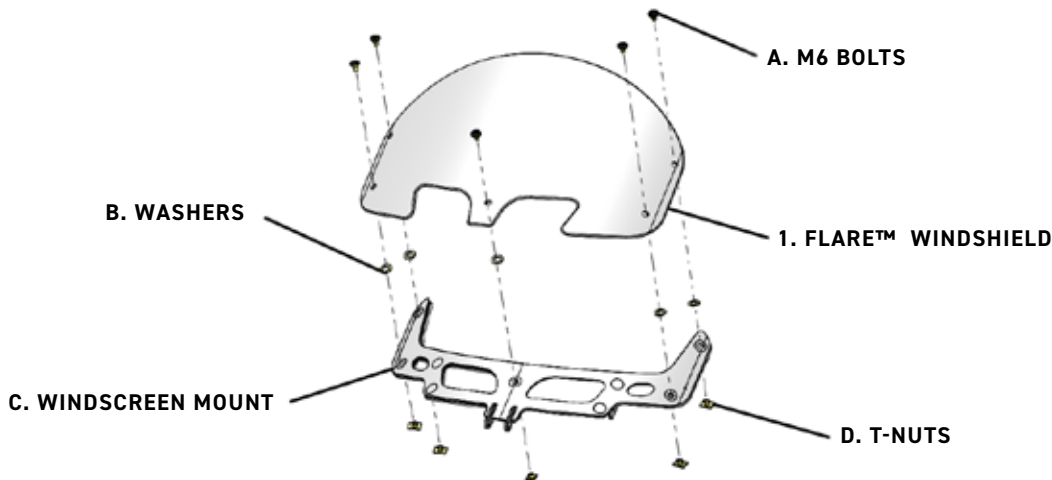

REMOVAL

1. With power windscreen extended in the upward most position, remove five M6 bolts and five T-nuts and retain for re-assembly. T-nuts are located on the back side of the windscreen mount. The five rubber washers between the windshield and windscreen mount do not need to be removed.

INSTALLATION

2. Place new Flare® Windshield (1) over windscreen mount (C) ensuring five washers (B) are in place.
3. Re-install the retained five rear T-nuts (D) and finger tighten five M6 bolts (A) ensuring that the shoulder of the bolts has engaged the Flare® Windshield (1). Torque M6 bolts to 36 +/- 6 in. lbs. (4.67 +/- 0.6 Nm).



WARNING! Using Loctite® or any type of thread locker on hardware will result in breakdown of the Polycarbonate and cause cracking.

Klock Werks cannot be held responsible for any damage resulting from improper installation performed by any consumer or their dealer.

U.S. Pat. No. D586,274; D632,235; D586,275; D633,017; D626,046; D633,018 Pat. 001050165-0001, 001050165-0002, 001050165-0003 APO No. 324093, 324094, 325192