

Thank you for purchasing our Apollo heated grips. Before installing, please read carefully the instruction sheet and retain it for future reference.

ATTENTION!

1. The Apollo heated grips are made to work on DC 12 volts applications only.
2. For proper installation, please follow the steps in the instruction sheet. Any damages caused by wrong installation shall be imputed to the users.
3. Opening or modifying the heated grips will void any warranty. Maintenance should be executed by our professionals only.

MARK MEANING

- Some procedures must be followed to avoid damages to the product.
- WARNING!** Some procedures must be followed to avoid damages to the user or others.
- CAUTION!** Some procedures must be followed to avoid damages to the vehicle.
- READ CAREFULLY!** If any information in the instruction sheets remains unclear, please seek for professional assistance



PRESS THE
BUTTON
ONCE

1 ACCESSORIES

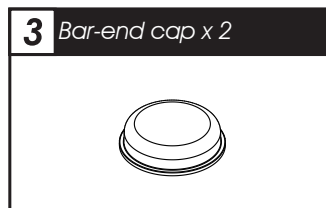
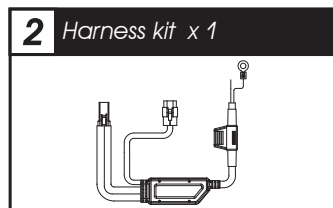
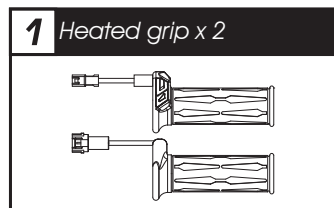

NOTE Please contact your local distributor if the items received are not the same as the one listed above.

2 WIRING INSTALLATION INSTRUCTIONS

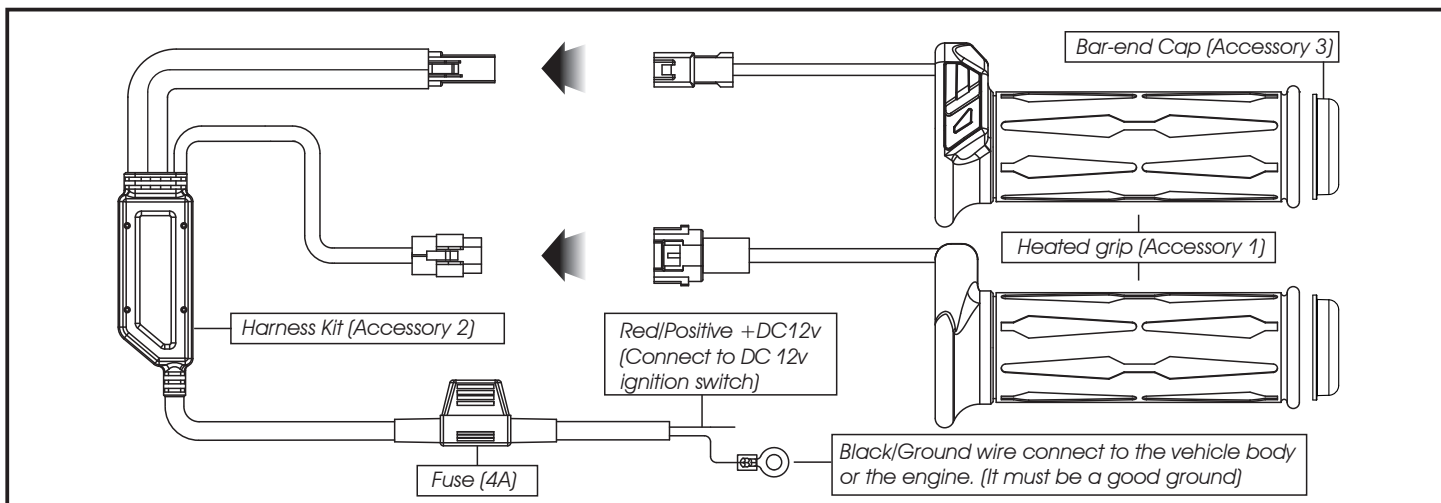

3 HEATING FUNCTION INSTRUCTION

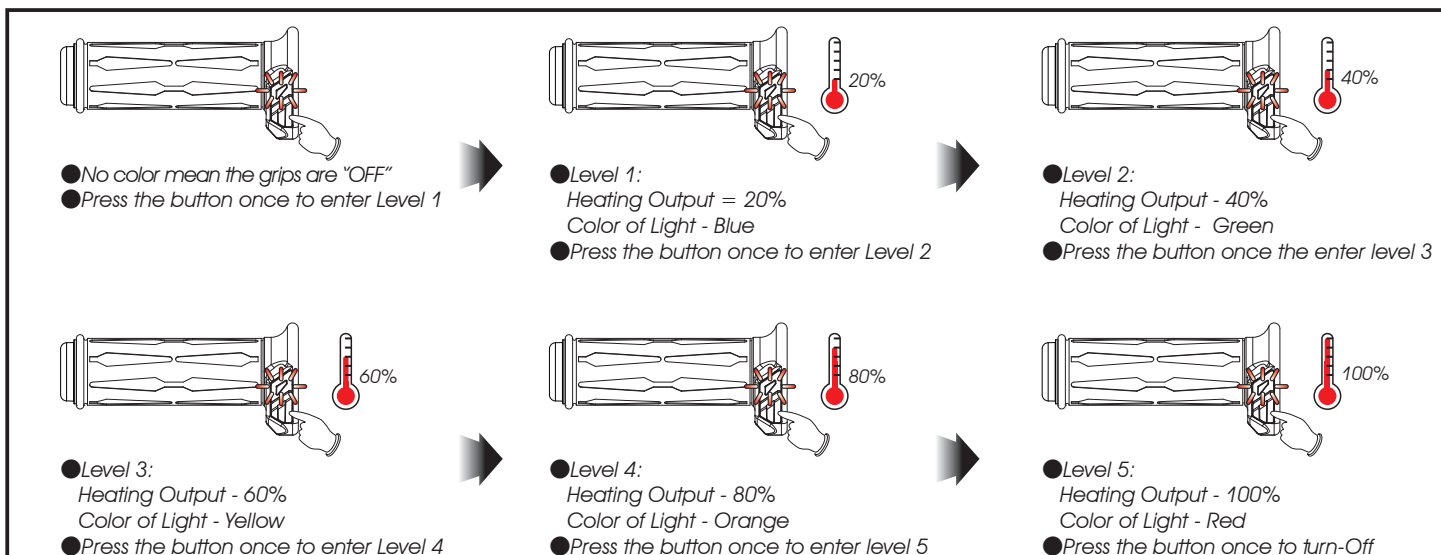

NOTE Press and hold the button for 3 seconds will turn-off the heated grips at any level.

NOTE The Apollo heated grips features a memory function. When the grips are switched OFF, press the control button for 3 seconds to restore automatically the previous heating level.

4 APOLLO HEATED GRIPS DATA

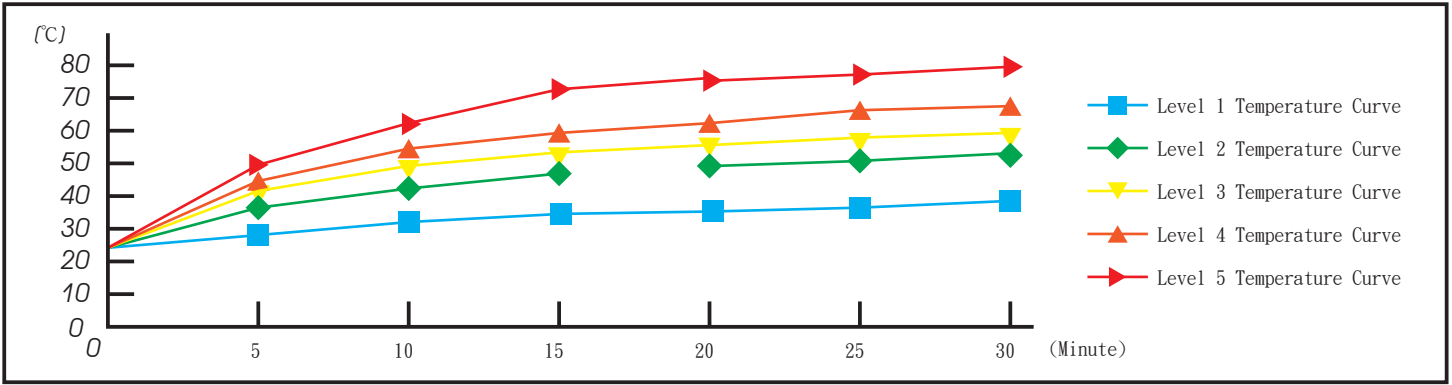

NOTE Testing environment under 25 Degrees Celsius. Working voltage at 13.5V.

5 LOW BATTERY WARNING INSTRUCTION

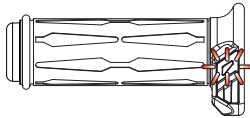

- If the voltage goes below 11.5V for more than 5 seconds, the heated grips will turn OFF automatically.
- The LED indicator will turn Purple and flash to indicate low voltage.
- Press the button once during warning to temporarily deactivate the warning.

NOTE To restore the normal operating status: make sure the voltage is above 12.5V.

6 CAUTION

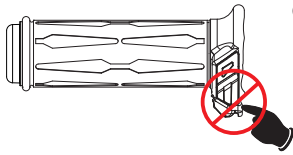

- Do not push the rubber part too hard, otherwise the heated grip might break.

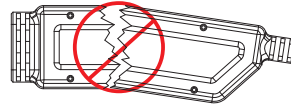

- Do not bend the in-line control unit, otherwise it might break.

7 TROUBLE SHOOTING

The following situation do not necessarily indicate a malfunction. Please check the following points before taking it in for repair.

TROUBLE-1	CHECK POINT
The LED indicator doesn't light up.	<ul style="list-style-type: none"> ● Improper connection between the connectors. → Check each connectors to make sure the connections are OK. ● The fuse is burned. → Replace the 4A fuse.

※ If the problem still occur, please contact your KOSO dealer.