



Thank you for purchasing our Koso EX-02 Speedometer. Before operating the unit, please read the instruction thoroughly and keep it for future reference.

Notice

1. The meter requires DC 12V power only.
2. For installation, please follow the steps described below. Any damage caused by a wrong installation shall be imputed to the users.
3. To avoid short circuits, do not pull the wires off the connector when installing the unit. Do not break or modify the wire terminal.
4. Do not disassemble or change any parts.
5. Repair and maintenance should be executed by our professionals only.

MARK MEANING:

- Some procedures must be followed to avoid damage caused by a wrong installation.
- WARNING!** Some procedures must be followed to avoid injuries.
- CAUTION!** Some procedures must be followed to avoid any damage to the vehicle.



1-1 Accessories

<p>1 Meter X1</p>	<p>2 Meter plate X1</p>	<p>3 Handlebar bracket X1</p>	<p>4 7/8" (22.2mm) Rubber X1</p>
<p>5 1" (25.4mm) Rubber X1</p>	<p>6 1 1/8" (28.6mm) Rubber X1</p>	<p>7 1 1/4" (32 mm) Rubber X1</p>	<p>8 M4 x 10 Screw X2</p>
<p>9 M4 x 12 Screw X1</p>	<p>10 M5 x 18 Screw X1</p>	<p>11 M5 Washer X2</p>	<p>12 3 mm Allen key X1</p>
<p>13 4 mm Allen key X1</p>	<p>14 Mid-way connector X2</p>		

NOTE Please contact your local distributor if the items received are not the same as the above-listed ones.

1-2 Optional accessory

2 External button

NOTE Some optional accessories may not be sold in your area. For more details, please contact your local distributor.

2-1 Wiring installation instruction

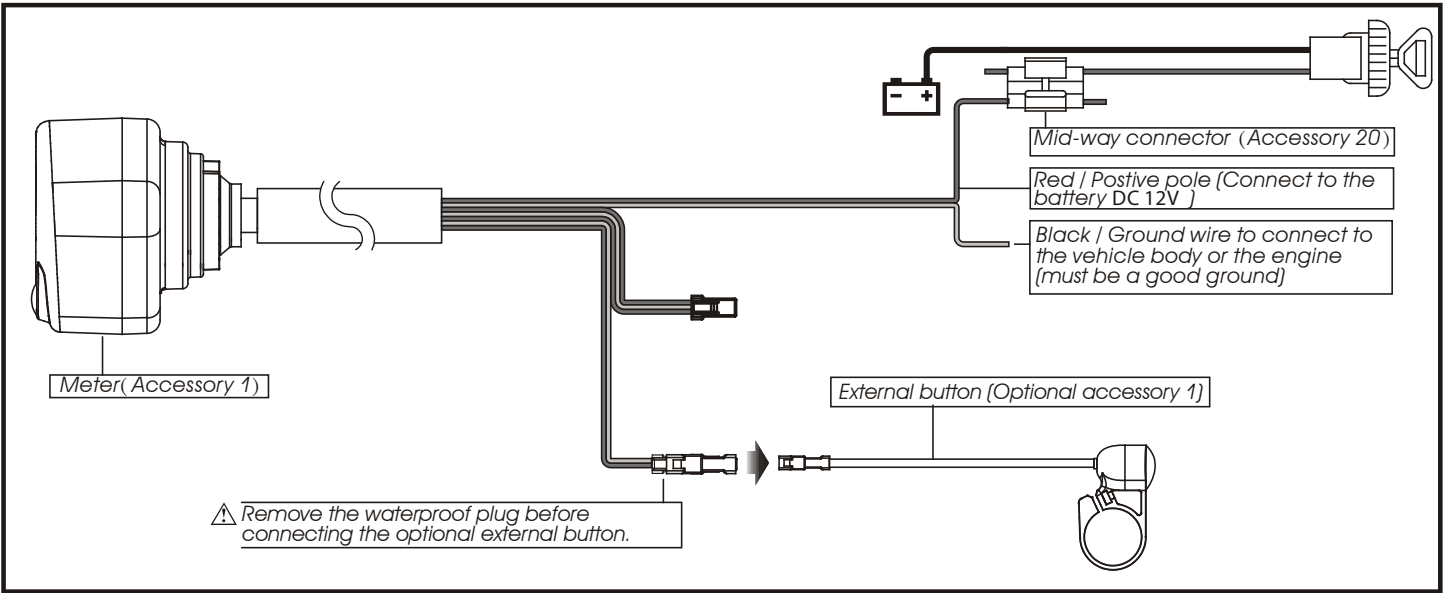

2-2 Installation instruction

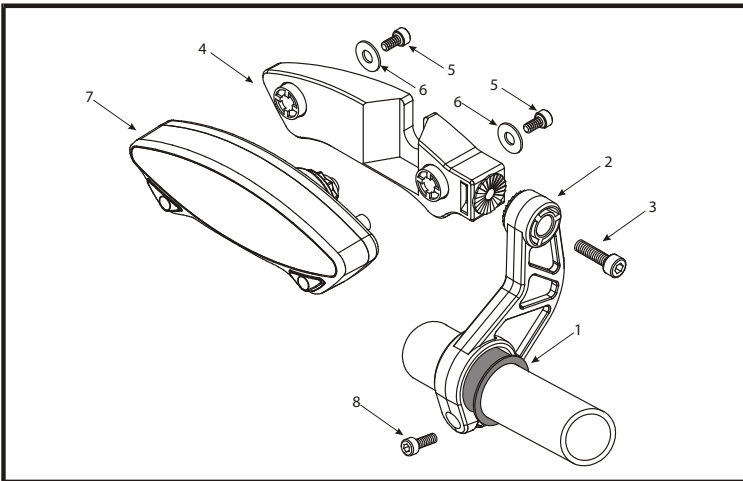

Follow this procedure for proper installation

1. Rubber (Accessory 4 · 5 · 6 · 7)
2. Handlebar bracket (Accessory 3)
3. M5 x 18 Screw (Accessory 10)
4. Meter plate (Accessory 2)
5. M4 x 10 Screw X2 (Accessory 8)
6. M5 Washer X2 (Accessory 11)
7. Meter (Accessory 1)
8. M4 x 12 Screw (Accessory 9)

NOTE Adjust the meter to the proper viewing angle before tightening the Allen screw.

2-2 Basic function instruction

Speedometer

- Display range: 0~360km/h (0~225 MPH).
- Display unit: km/h (MPH).

Odometer

- Display range: 0~99,999 km (mile), automatically resets after 99,999 km mile .
- Display unit: 1 km (mile).

Trip meter

- Display range: 0~9999.9 km (mile), automatically resets after 9999(9 km) mile .
- Display unit: 0.1 km (mile).

Select button

- Press the Select button on the main screen to switch between 12、24 hour mode, speedometer record, stopwatch , and MAX record.

Adjust Button

- Press the Adjust button on the main screen to switch between ODO, TripA、B, Total Hour meter, Hour meter A、B.

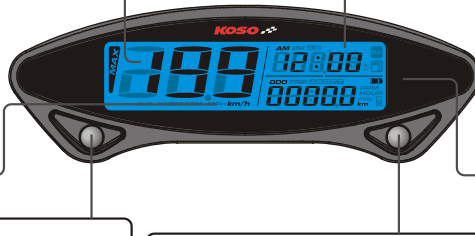

- Clock: 12、24 MODE
- Volt meter: DC 8~18 V
- Stopwatch function: can be either programmed for manual activation or by wheel activation
- MAX Record function : Average speed : 0~360 km/h (0~225 MPH) MAX Speed : 0~360 km/h (0~225 MPH) MAX voltage : DC 8~18 V

- Inner battery display range: 4 levels.

2-3 Function specifications

● Speedometer	Display range : 0~360 km/h (0~225 MPH) Display unit : 1 km/h & MPH for alternative	● Stopwatch	Display range : 0'00"00~9'59"99 Display unit : 0.01 sec.
○ Display internal	<0.5 second	● Maintenance Mileage	Setting range : 300~5,000 km automatically resets after 5,000 km Setting unit : 1 km
○ Odometer	Display range : 0~99,999 km (mile) automatically resets after 99,999km (mile) Display unit : 1 km (mile)	● MAX Record function	Average speed : 0~360 km/h (0~225MPH) MAX Speed : 0~360 km/h (0~225 MPH) MAX voltage : DC 8~18 V
○ Trip meter A.B	Display range : 0~9999.9 km (mile) automatically resets after 0~9999.9 km (mile) Display unit : 0.1 km (mile)	● Inner Battery Level	Display range : 4 levels
● Hour meter	Display range : 0~99,999 hour Display unit : 0.1 hour	● Effective temperature range	-10~+60°C
○ Hour meter A.B	Display range : 0~9999.9 hour, automatically resets after 9999.9 hours Display unit : 0.1 hour	● Meter standard	JIS D 0203 S2
● Clock	Setting range : 12、24 hours Setting unit : 1 minute	● Meter size	120 X 40 X 23 mm
● Volt	Display range : DC 8~18 V Display unit : 0.1V	● Meter weight	+/- 127g

NOTE Design and specifications are subject to change without notice!

2-4 Battery replacement

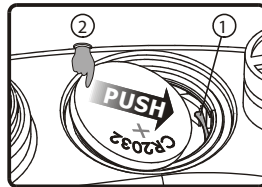
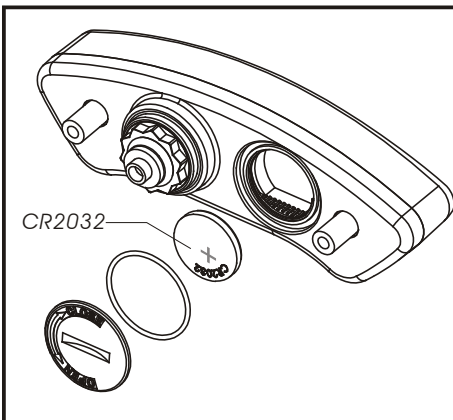

Figure A

Follow this procedure for proper installation.

- The meter includes an internal battery (CR2032). This battery shall be replaced only when power runs out.
- In order to install the battery properly, push the battery as show on figure (A) to make sure the battery is placed underneath the metal tab (1).

⚠ WARNING! Not following this procedure could result in permanent damage to the meter.

3 Switch function instructions

● Instructions for select button

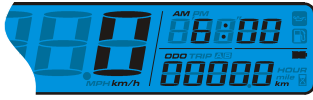

● Press the Select button while on main screen to switch from Clock to Stopwatch.

● Press and hold the Select button for 3 seconds to alternate 12/24hour modes.



NOTE If 24hour mode is chosen, then the AM/PM symbol will not be displayed.



● Press the Select button to switch from Stopwatch to Volt meter.

NOTE When the option for manually resetting the stopwatch is chosen, press Select button and hold for 6sec. to switch to Voltmeter.

● Press and hold the Select button for 3 seconds to reset the Stopwatch.

NOTE If the button setting is "ON", then press the Select button to start counting and press Select button again to stop.

NOTE If button setting is "OFF", then press the external button (optional) to start counting and press again to stop.

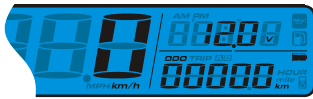

● Press the Select button to switch from Voltage to Speed Record.



CAUTION To switch from Stopwatch to Speed Record, you must have a record for the Stopwatch (please do not reset the Stopwatch). When Stopwatch is reset, pressing the Select/External button will start the Stopwatch function again.



● Press the Select button to switch from Speed record to clock meter.

● Press and hold the Select button for 3 seconds to reset the Speed Record



NOTE When Maintenance Symbol is ON, please reset under this function screen.



● Back to clock screen.

● Instructions for adjust button



● While on main screen, press the adjust button once to switch the function from odometer to trip A.

● While on odometer screen, press and hold the Adjust button for 3 seconds to change the speed unit.

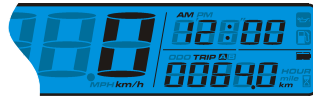

● Press the Adjust button to switch from trip A to trip B.

● Press and hold the Adjust button for 3 seconds to reset the trip A.



● Press the Adjust button to switch from trip B to total hour meter.

● Press and hold the Adjust button for 3 seconds to reset the trip B.



● Press the Adjust button to switch from total hour meter to hour meter A.



● Press the Adjust button to switch from hour meter A to hour meter B.



● Press the Adjust Button to exit from Hour Meter B and to go back to odometer screen.



● Back to the odometer screen.

4 Setting Mode



- While on main screen, press the Adjust+Select 3 sec. to enter the tire circumference and sensing point settings (for setting a different tire size.)



- Use the Adjust button to set the proper tire circumference.

4-1 The tire circumference and sensing point setting



- EX. The tire circumference is 1300 mm.
- Press the Adjust button to move to the digit you want to set.



NOTE

The tire circumference setting range is from 300 to 2500 mm.

NOTE Default setting : 1000mm

P.S.

Use the valve stem as the starting point and the terminal point to measure the wheel circumference with a measuring tape.

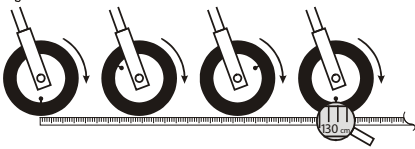

- EX. The tire circumference setting is changed from 1000 mm to 1300 mm.
- Press the Select button to change the setting.



- Press the Adjust button three times to enter the sensing point setting.

4-2 Sensing point setting



- EX. To change the sensing point to 6.
- Press the Select button to move to the digit you want to set.



NOTE The sensing point settings range from 1 to 60 points.

NOTE Default value: 1



- EX. the sensing point setting has been changed from 1 to 6.
- Press the Select button to choose the hour you want to set.



- Press Adjust button to go back to tire circumferences value & sensing point setting screen.



- From a 1 switch to a 2 screen.



- Press the Select button to enter the clock (Hour) setting

4-3 The clock (Hour) setting



- EX: The hours have to be set to 14.
- Press the Select button to choose the hour you want to set.



NOTE Setting range: 0~24 H.



- EX. The hours have now been changed from 0:00 to 14:00.
- Press the Adjust button to enter the minute setting.

4-4 The clock (minute) setting



- EX. To change the setting to 14:05.
- Press the Select Button to choose the minute to be set.



NOTE Setting range: 0~59 minutes.

- EX. The time is now changed to 14:05.
- Press Adjust button to go back to Clock setting screen.



- From a 2 switch to a 3 screen.



- Press the Select button again to enter the Stopwatch Setup

4-5 Stopwatch Setup



- Press Adjust button to choose between Auto mode (Stopwatch starts/stops according to the wheel rotation) and Manual mode (Stopwatch starts/stops by pressing the meter button of the optional thumb switch).
- If AUTO option is chosen, press Adjust button to exit the Stopwatch setup



NOTE Default value: AUTO



- If Manual mode "SW" (switch) option is chosen, press Adjust button to enter the menu then Select button to switch between "ON" (external button - optional) or "OFF" (meter button).



NOTE Default value: OFF

- Press the Adjust button to enter the ODO setting.



- From a 3 switch to a 4 screen.



- Press the Adjust button to enter the Maintenance Oil Light Setting.

4-6 Maintenance Oil Light Setting



- Ex. Select ON/OFF to enable/disable the maintenance oil light function.
- If OFF is selected, then press the Adjust button once to exit the maintenance mileage setting.



NOTE Default value: OFF

- If ON is chosen, press Adjust button to enter the maintenance oil light setting
- Press the Adjust button to move the cursor to the digit to be set.



- If OFF is chosen, then press the Adjust button to exit the maintenance oil light setting.



● From **2** 4 switch to **2** 5 screen.



● Press the Adjust button to enter the Backlight Brightness setting

● 4-7 Backlight brightness



- EX. To change the Backlight brightness setting to 1.
- Press the Select button to adjust the brightness of the backlight



NOTE Adjustable Range: 1 ~ 5

NOTE Default value: 5



- EX. The Backlight brightness setting is changed from 5 to 1
- Press the Adjust button to confirm and exit the backlight Brightness setting



● From **2** 5 switch to **2** 6 screen.



● Press the Adjust button to enter the ODO setting.

● 4-9 ODO setting.

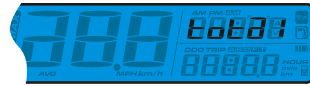

● Press the Adjust button again to view the actual meter mileage under TOTAL.



● EX. To set the customized mileage adjustment under USER.

● Press the Select Button to switch from Total ODO to User ODO setting.



● EX. To change the ODO setting of 5000 km.

● Press the Adjust button to enter the desired ODO value to be set.

● EX. The User ODO to be set is 3000 km.

● Press the Adjust button to move the cursor to the digit to be set.



NOTE Setting range : 00000 ~ 99999 km.
Setting unit : 1 mm.

NOTE Default value: 0



● Press the Select button to choose the digit to be set.



● Press the Adjust button to go back to the ODO viewing display

● Then press and hold both the Adjust and Select buttons 3 sec. to exit and go back to the main screen.

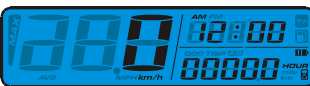
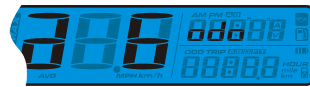

● Back to the main screen.

5 Troubleshooting

The following situations do not necessarily indicate a malfunction to the meter. Please check the following before taking it in for repair.

Problem	Diagnosis
The meter doesn't work when the power is on.	<ul style="list-style-type: none"> ● The power is not supplied properly to the meter. <ul style="list-style-type: none"> → Make sure the wiring is connected correctly. The wiring and fuse may be broken. → The battery is too old to supply enough power to make the meter work.
The meter shows wrong information	<ul style="list-style-type: none"> ● Check the battery voltage and make sure that it supplies enough power.
Speed does not appear or appear incorrectly.	<ul style="list-style-type: none"> ● Make sure that the speed sensor is connected properly. ● Check the tire-size setting. <ul style="list-style-type: none"> → refer to manual 4-1.

Problem	Diagnosis
Clock is incorrect	<ul style="list-style-type: none"> ● Check if the wire is connected properly <ul style="list-style-type: none"> → Check if the positive wire (Red) is connected to the battery and the main switch positive wire (Brown) is connected to the main switch.
Battery power lower than level 1.	<ul style="list-style-type: none"> ● The problem may be caused by insufficient power. <ul style="list-style-type: none"> → Replacement of the internal battery may be necessary.

※ If the problem can still not be solved according to the steps above, please contact your local distributor to get assistance.

EX-02 ENDURO • Specific installation instructions



FOR KTM



1. Install the magnet and clip into the disc-brake.
 2. Locate the speed sensor housing and screw on the sensor until it is tight.
- * Sensor and magnet must be max. 2-3 mm apart.
3. Secure the speed sensor cable (you might have to use tye-wrap to hold it in place).

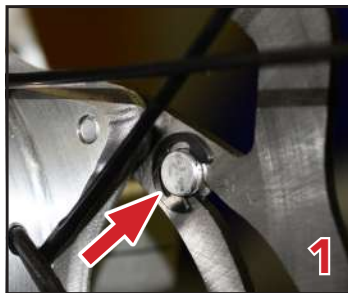
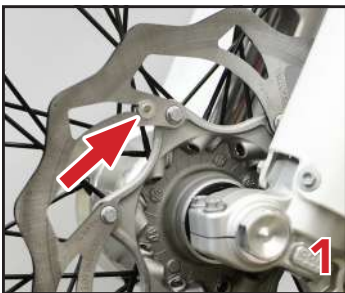

FOR OTHER APPLICATIONS



Magnetic bolt
For Honda



Magnets
For Kawasaki
Suzuki
Yamaha

1. Remove the plastic fork guard.
 2. a - For Kawasaki, Suzuki, Yamaha: Insert **ONE** magnet into one of the the disc-brake bolts head, the north face of the magnet (identified by a red line) must face the speed sensor.
 2. b - For Honda: replace of the stock disc-brake bolt with the magnetic bolt.
- * Sensor and magnets/magnetic bolt must be max. 2-3 mm apart.
3. Using brake-cleaner or any grease remover, clean the fork and wipe dry.
 4. Install the speed sensor bracket as shown below.
 5. Insert the speed sensor into the bracket housing and use the nuts to tighten them.
 6. Secure the speed sensor cable (you might have to use tye-wrap to hold it in place).
 7. Place the fork guard back on (you might have to alter the guard so that the bracket can fit).



OR

