



• Thank you for purchasing the our product. Before installing, please read the instruction carefully and keep it for future reference.

## ⚠ Notice

- Please, follow the step-by-step instructions for proper installation. Any damages caused by faulty installation shall be imputed to the users.
- To avoid a short circuit, do not pull the wires when installing the unit. Do not break or modify the wires either.
- Do not disassemble or change any parts.
- Maintenance and repairs should be executed by our professionals only.

©MARK MEANING:

⚠ Some procedures must be followed to avoid faulty installation.

**⚠ WARNING!** Some procedures must be followed to avoid damages from occuring to yourself and to others.

**⚠ CAUTION!** Some procedures must be followed to avoid damages from occuring to the vehicle.

**🔧 READ CAREFULLY!** If any information remains unclear, after following the instructions, please seek professional assistance.



FLASH



LIGHT ON









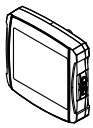

PRESS THE  
BUTTON  
ONCE

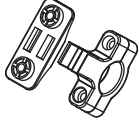
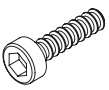

PRESS THE  
BUTTON 3  
SECONDS

## 1-1 Accessories

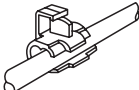
<b>1</b> Meter X 1 	<b>2</b> Speed sensor X 1 	<b>3</b> D6 X 5L mm magnet X 6 	<b>4</b> M8 / S type speed sensor bracket X 1 
<b>5</b> M10 / S type speed sensor bracket X 1 	<b>6</b> M5 X 5L mm Hexagon screw X 2 	<b>7</b> Meter bracket X 1 	<b>8</b> M5 X 12L screw X 2 
<b>9</b> M4 X 10L screw X 2 	<b>10</b> M5 washer X 2 	<b>11</b> Mid-way connector X 4 	

**NOTE** Contact your local distributor, if the items received in the box are not the same as the items listed above.

## 1-2 Optional accessories

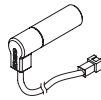
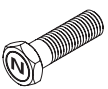
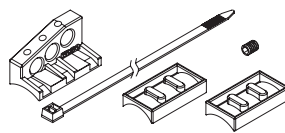
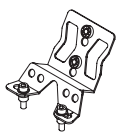
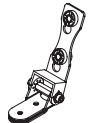
<b>1</b> Active speed sensor 	<b>2</b> Disc magnet screw  <p>5/16-18 X 22.1L M5 X P0.8 X 12L M6 X P1.0 X 12.6L M6 X P1.0 X 19.7L M6 X P1.0 X 24L M8 X P1.25 X 22.5L M8 X P1.25 X 27.5L M8 X P1.25 X 29L M10 X P1.25 X 28.3L</p>	<b>3</b> L TYPE speed sensor bracket 	<b>4</b> Meter bracket 
<b>5</b> Meter bracket 			

**NOTE** Some of the optional accessories may not be available in your area. Contact your local distributor to obtain more information.

## 2-1 Wiring installation instructions

Mid-way connector (Accessories 11)

Red / Positive pole (Connect to the battery DC 12 V)

Green - Fuel

Brown / "+" Wire connect to the DC 12 V ignition switch

Black / Ground wire connect to the negative pole of the battery (must be a good ground)

Meter (Accessories 1)

Speed sensor (Accessories 2)

Magnet (Accessories 3)

Main power switch wire reference:

	Power	Key on	Ground
YAMAHA	Red	Brown	Black
HONDA	Red	Red / Black	Green
SUZUKI		Black	Green
KAWASAKI	White	Brown	Black / Yellow
KYMCO	Red	Black	Green
SYM	Red	Black	Green
PGO	Red / White	Orange	Black

**NOTE** The colors listed above may differ depending on the model and year of the vehicle.

RPM wire reference:

	YAMAHA	HONDA	SUZUKI	KAWASAKI	APRILIA	BENELLI	BUELL	CAGIVA	DUCATI	H-D	MV	TRIUMPH
	Yellow / Black	Yellow / Green	Yellow / Blue	Light Blue	Gray / Violet	Gray / Violet	Pink	Gray / Green	Gray / Green	Pink	Gray / Yellow	Red

**NOTE** The colors listed above may differ depending on the model and year of the vehicle.

Fuel indicator wire reference:

	YAMAHA	HONDA	SUZUKI	KAWASAKI	KYMCO	SYM	PGO
	Green	Yellow / White	Yellow / White	Black / L Green	Yellow / White	Yellow / White	Gray

**NOTE** The fuel sensor is electronic type, do not connect in parallel with the original wire - otherwise the fuel gauge won't display. **The wrong installation of the fuel wire might damage the instrument.**

⚠ N pole of the Magnet needs to be facing outward (facing the sensor) and must be installed on the brake disk or chain gear fixing bolt.

**NOTE** When connecting the power wire, follow the instructions carefully. If the red & brown wires are connected in parallel, the meter will not work properly.

## 2-2 Installation instructions

Follow the steps below during installation.

1. M5 X 12L screw X2 (Accessories 8)  $\times$  2.9 Nm (29 kgf.cm)
2. Meter bracket (Accessories 7)
3. Fix the bracket on handle bar (7/8")
4. M4 X 10L screw X2 (Accessories 9)  $\times$  1.12 Nm (11.2 kgf.cm)
5. M5 washer X2 (Accessories 10)
6. Meter bracket (Accessories 7)
7. Meter X1 (Accessories 1)

**NOTE** Adjust the meter to the proper angle before tightening the handle bar bracket screws.

## MOTO / SCOOTER Magnet installation instructions

1. Put the magnet into the brake disc screw hole.
2. Install the s type sensor bracket.
3. Adjust the sensor bracket position to make sure the sensor is facing the magnet to receive good speed signal.
4. Install the speed sensor on the bracket.
5. In order to get a good speed signal, the distance between the speed sensor and magnet should be under 8 mm.

P.S.



Higher number of magnets installed on the disk brake will result in a faster speed display on the gauge. The letter "N" on the magnets must face the speed sensor in order to pick up the speed correctly.

- EX 1: If the disk brake has 3 screws, you can install 1 or 3 magnets.
- EX 2: If the disk brake has 4 screws, you can install 1, 2 or 3 magnets.
- EX 3: If the disk brake has 5 screws, you can install 1 or 5 magnets.
- EX 4: If the disk brake has 6 screws, you can install 1, 2, 3 or 6 magnets.

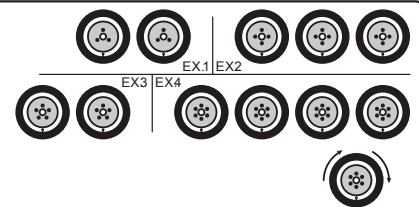

### 3-1 Basic function instructions

**Odo meter**

- Display range : 0 ~ 99,999 km (mile) , reset automatically after 99,999 km (mile) 
- Setting unit : 1 km (mile)

**Trip meter A、B**

- Display range : 0 ~ 9,999.9 km (mile) , reset automatically after 9,999.9 km (mile)
- Setting unit : 0.1 km (mile)

**Hour meter**

- Display range : 99,999 hour , reset automatically after 99,999 hour 
- Display unit : 1 hour

**Hour meter A、B**

- Display range : 9,999.9 hour , reset automatically after 9,999.9 hour
- Display unit : 0.1 hour

**Fuel meter**

- Display range : 6 levels
- Display unit : Each level represents 16.6 %



**Speedometer**

- Display range : 0 ~ 360 km/h (0 ~ 225 MPH)
- Display unit : km/h or MPH alternative

**Clock** 

- 24 H

**Volt meter** 

- Display range : DC 8.0 ~ 18.0 V

**Volt meter warning** 



- Display range : Flashing warning when voltage lower than 11.5 V or higher than 15.5 V

**Select**

**Adjust**

**Speed record**

- MAX speed record :  
Display range : 0 ~ 360 km/h (0 ~ 225 MPH)
- Average speed record :  
Display range : 0 ~ 360 km/h (0 ~ 225 MPH)



### 3-2 Function setting instructions

> Speedometer	Display range : 0 ~ 360 km/h (0 ~ 225 MPH) Display unit : km/h or MPH for alternative	> MAX speed record	Display range : 0 ~ 360 km/h (0 ~ 225 MPH)
> Display internal	<0.5 second	> Average speed record	Display range : 0 ~ 360 km/h (0 ~ 225 MPH)
> Odometer	Display range : 0 ~ 99,999 km (mile) , reset automatically after 99,999 km (mile) Setting unit : 1 km (mile)	> Tire circumference	Setting range : 300 ~ 2,500 mm Setting unit : 1 mm ; Sensitive point : 1 ~ 6
> Trip meter A、B	Display range : 0 ~ 9,999.9 km (mile) , reset automatically after 9,999.9 km (mile) Display unit : 0.1 km (mile)	> Fuel meter	Display range : 6 grids
> Oil maintenance mileage	Setting range : 300 ~ 5,000 km (mile) Setting unit : per 100 km (mile)	> Insufficient fuel warning	Setting unit : 100 Ω、250 Ω、510 Ω、USER
> Hour meter	Display range : 99,999 hour , reset automatically after 99,999 hour Display unit : 1 hour	> Clock	24 H
> Hour meter A、B	Display range : 9,999.9 hour , reset automatically after 9,999.9 hour Display unit : 0.1 hour	> Volt meter	Display range : DC 8.0 ~ 18.0 V
		> Volt meter warning	Display range : Flashing warning when voltage lower than 11.5 V or higher than 15.5 V
		> Effective voltage	DC 12 V
		> Effective temperature range	-10 ~ +60 °C
		> Meter standard	JIS D 0203 S2
		> Meter size	77.5 X 74.8 X 34 mm
		> Meter weight	Around 87 g

NOTE Design and specifications are subject to change without notice!

### 3-3 The main screens function switch instructions

● **Select** button function instructions



- In the clock screen, Press the **Select** button one time to enter the volt screen.

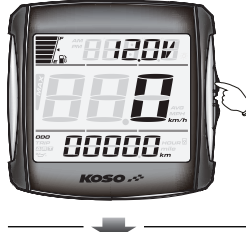

- In the volt screen, Press the **Select** button one time to enter the clock screen.

**NOTE** If Clock function set as OFF, then the meter will only display the voltage in that screen position.



● In the clock screen.

### ● Adjust button function instruction



● In the ODO screen, Press the **Adjust button** one time to enter the Trip A screen.

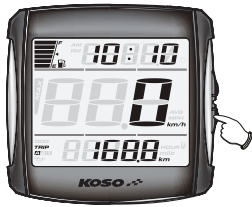

● In the Trip A screen, Press the **Adjust button** one time to enter the Trip B screen.

● Press and hold the **Adjust button for 3 seconds** to reset Trip A record.



● In the Trip B screen, Press the **Adjust button** one time to enter the oil maintenance mileage screen.

● Press and hold the **Adjust button for 3 seconds** to reset Trip B record.

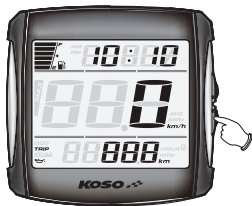

● In the oil maintenance mileage screen, Press the **Adjust button** one time to enter the hour meter screen.



● In the hour meter screen, Press the **Adjust button** one time to enter the hour meter A screen.

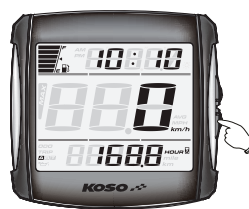

● In the hour meter A screen, Press the **Adjust button** one time to enter the hour meter B screen.

● Hold pressing **Adjust button for 3 seconds** to reset hour meter A records.



● In the hour meter B screen, Press the **Adjust button** one time to enter the Speed record (MAX - AVG) screen.

● Press and hold the **Adjust button for 3 seconds** to reset hour meter B records.

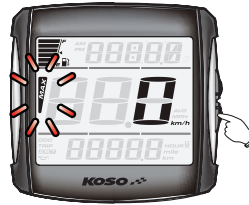

● In the Speed record (MAX - AVG) screen, Press the **Adjust button** one time to enter the ODO screen.

**NOTE** MAX Speed Record (MAX) and Average Speed Record (AVG) will switch between each other every 3 seconds.



● Press and hold the **Adjust button for 3 seconds** to reset MAX speed record.



● Press and hold the **Adjust button for 3 seconds** to reset Average speed record.



● In the ODO screen.

## 3-4 Oil maintenance mileage setting instructions

**P.S.**

- When the running distance reaches the maintenance distance setting. The oil change symbol will light up. The indicator light can be turned off after resetting the records.
- The oil mileage is counted by decreasing.



● **Example** : We already did the maintenance work after the oil change symbol lit up.

● In the main screen, press **Adjust button** to enter Oil maintenance mileage screen.

⚠ The oil change symbol is lit up now.

**NOTE** If you maintained the scooter before the oil change symbol lit up, you could also reset the oil maintenance distance to remind yourself for the next maintenance time.





- In the oil maintenance mileage screen, Press the **Adjust button** for 3 seconds to enter the Maintenance Mileage "Reset" screen .

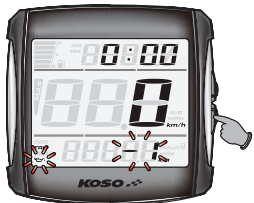

- Press the **Adjust button** for 3 seconds to confirm the Maintenance Mileage to be reset.
- ⚠ In Maintenance Mileage Reset screen, press the Adjust button to give up the reset and then warning light will back to light on steady from flashing.

**NOTE** In Maintenance Mileage Reset screen, press the Adjust button to give up the reset and then the oil change symbol will back to light on steady from flashing.



- Maintenance Mileage "Reset" screen.
- EX. The Maintenance Mileage to be reset from -1 to setting value.

⚠ The reset value will depend on the setting value according to 4-5 Maintenance Mileage Setting.

### 3-5 Setting screen instruction



- In main screen

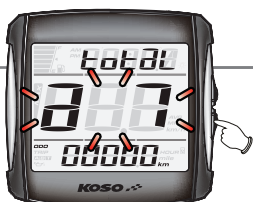

- Internal ODO display



- Odometer



- Oil maintenance mileage

- In main screen, press down the **Select & Adjust button** at the same time for 3 seconds to enter the setting screen.
- Press the **Adjust button** to select in following order start from Circumference and sensing point · Fuel gauge resistance (Ω) · Clock setting · Backlight brightness setting · Oil maintenance mileage · Odometer · Internal ODO display .

**NOTE** The screen will return to the main screen after 30 seconds if no button is press.

Ⓜ In any screen, you could hold down the **Select button** for 3 seconds to back to the main screen.



- Setting screen

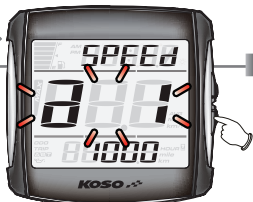

- Circumference and sensing point

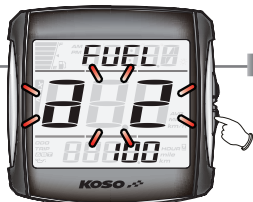

- Fuel gauge resistance



- Clock setting



- Backlight brightness setting

### 4 Entering setting screen



- In main screen, press down the **Select & Adjust button** for 3 seconds to enter the setting screen.

#### 4-1 Circumference and sensing point setting



- Press the **Select button** to enter the circumference and sensing point setting screen.

#### ⚠ CAUTION!

- Measure the tire circumference (The tire you will install the sensor on) and make sure the number of magnet sensor point (You could install the magnet into the disc screw or the sprocket screw.)
- The speed displayed on the meter will be affected by the setting, make sure the setting number is correct before you make the setting.

⚠ **Reset this setting value when you change a different size tire.**

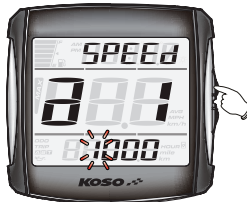

- Example : If the tire circumference is 1,300 mm.
- Press the **Select button** to the digit you want to set.
- EX. Now the tire circumference is setting from 1,000 mm.

⚠ Now the digit in thousands setting number is flashing!

**NOTE** Setting range : 300 ~ 2,500 mm  
Setting unit : 1 mm

**P.S.**



- You could define the valve as the starting point and the terminal point to measure the wheel circumference with a measuring tape.

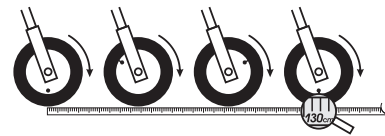



- Press the **Adjust** button to choose the setting number.



- Press the **Select** button to enter the sensor point setting.
- Ex. The circumference setting is changed from 1,000 mm to 1,300 mm.

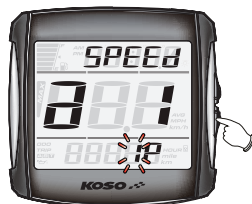

- **Example** : If the sensor point is setting 6P.
- Press the **Adjust** button to choose the setting number.
- Ex. Now the sensor point is setting from 1P.

⚠ **Now the setting value is flashing!**

**NOTE** Sensitive point : 1 ~ 6

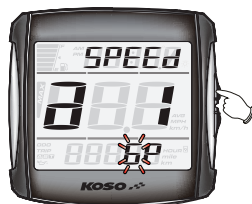

- Press the **Select** button to go back to the circumference and sensing point setting screen.
- Ex. Now the sensor point is setting from 1P to 6P.

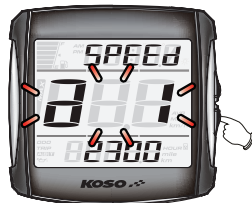

- Press the **Adjust** button to select the fuel gauge resistance setting screen.

## 4-2 Fuel gauge resistance settings

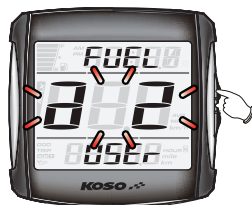

- Press the **Select** button to enter the fuel gauge resistance setting screen.

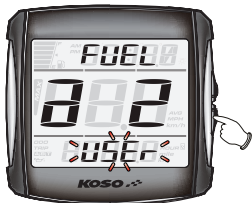

- **Example**: If the vehicle is a YAMAHA T-MAX 530; it's resistance is 100 Ω according to the service manual.

- Press the **Adjust** button to choose the setting number.

⚠ **Now the setting value is flashing!**

**NOTE** The fuel gauge resistance setting range : USER、100 Ω、250 Ω、270 Ω、510 Ω、1200 Ω、SW (turn off)

**NOTE** Custom fuel level resistance:  
1) Manual - Please check 4-2-1 Fuel Level Resistance Manual Setting Instructions.  
2) Auto - Please check 4-2-2 Fuel Level Resistance Auto Setting Instructions.

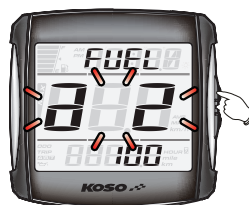

- Press the **Select** button to go back to the circumference and sensing point setting screen.
- Ex. Now the circumference and sensing point setting from USER to 100 Ω.

### 4-2-1 Fuel Level Manual Setting

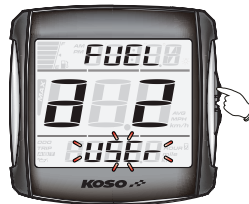

- Press the **Select** button to enter the lowest fuel level's resistance setting screen.
- **Example** : For YAMAHA T-MAX 530, according to the service manual, the fuel tank resistance from low to high is 90 - 100 Ω (the lowest) and 4 - 10 Ω (the highest). So enter the setting value as 10 Ω.

**P.S.**



- You could find your fuel level sensor resistance range in the electronic components section in the service manual.

- Normally, we will recommend to choose the closest number set as the range to ensure that riders will not run out of gas before the fuel level indication. example, for YAMAHA T-MAX it's 90 - 100 Ω and 4 - 10 Ω, in which case we will suggest to use 90 - 10 Ω as the lowest and highest range.

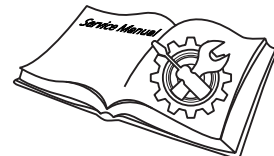

- **Example** : If the lowest fuel level is 90 Ω.
- Press the **Select** button to the digit you want to set.

⚠ **Now the setting value is flashing!**



- Press the **Adjust** button to choose the setting number.



- Press the **Select** button **twice** to enter in the highest fuel level's resistance setting screen.
- Ex. The lowest fuel level setting is changed from 0 to 90 Ω.

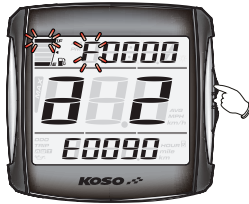

- **Example** : If the highest fuel level is 10 Ω.
- Press the **Select** button to the digit you want to set.

⚠ **Now the setting value is flashing!**

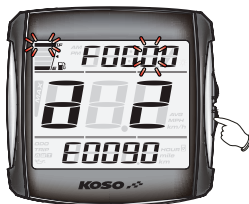

- Press the **Adjust** button to choose the setting number.

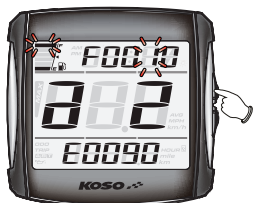

- Press the **Select button twice** to go back to the highest fuel level's resistance setting screen.
- EX. The highest fuel level setting is changed from 0 to 10 Ω.

#### 4-2-2 Fuel Level Resistance Auto Detection Settings



- Press the **Select button** to enter the lowest fuel level's resistance auto detection screen.

#### ▲ CAUTION!

- Before detection, ensure that your current fuel level is in the lowest position that you would like to have.
- Stop the vehicle for a few seconds to allow the fuel surface to become steady, then start the detection of the resistance.

P.S.



- For example of YAMAHA T-MAX 530, if the fuel surface sensor float in the lowest position then it will detect the resistance around 90 - 100 Ω.

The lowest position



- Press the **Adjust button** to detect the lowest fuel level's resistance.



- Press the **Select button 5 times** to enter the lowest fuel resistance auto detection screen.
- EX. Auto Detection the lowest fuel level resistance is 90 ohms.

#### ▲ CAUTION!

- Before detection, please ensure your current fuel level is in the highest position that you would like to have.
- Stop the vehicle for a few seconds to allow the fuel surface become steady, then start the detection of the resistance.

P.S.



- For example the YAMAHA T-MAX 530; if the fuel surface sensor float is in the highest position then it will detect the resistance as around 4 - 10 Ω.

The highest position

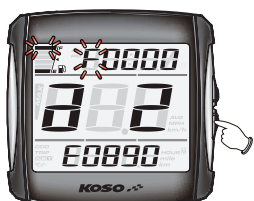

- Press the **Adjust button** to detect the highest fuel level resistance.



- Press the **Select button 5 times** to go back to the fuel gauge resistance.
- EX. Automatically detect the highest fuel level resistance value as 10 Ω.

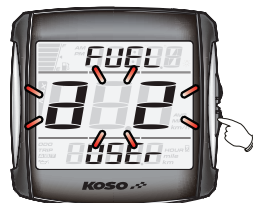

- Press the **Adjust button** to enter the Clock (Hr / Min) setting screen.

#### 4-3 Clock setting



- Press the **Select button** to enter the Clock (Hr / Min) setting screen.



- **Example** : Changing the hour to 10.
- Press the **Adjust button** to choose the setting number.

▲ Now the setting value is flashing!

**NOTE** Cursor moving order is : Hour > Digit in ten minutes > Digit in minutes

**NOTE** Setting Range:  
ON (Clock function enable)  
OFF (Clock function disable)

**NOTE** Setting range : 0 ~ 23 H.



- Press the **Select button** to enter the clock minutes setting screen.
- EX. Now the setting is changed from 0:00 to 10:00.



- **Example** : You want to change the minutes to 10.
- Press the **Select button** to the digit you want to set.

▲ Now the setting value is flashing!

**NOTE** Setting range : 00 ~ 59 minutes.



- Press the **Adjust button** to choose the setting number.



- Press the **Select button** to go back to the clock (Hr / Min) setting screen.
- EX. Now the setting is changed from 10:00 to 10:10.



- Press the **Adjust button** to select the Backlight brightness setting.



#### 4-4 Backlight brightness settings

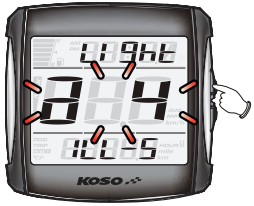

- Press the **Select** button to enter the backlight brightness setting screen.

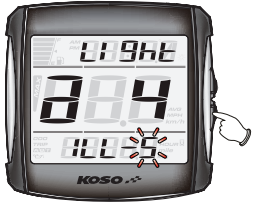

- **Example** : You want to set the brightness at 60% (3).
- Press the **Adjust** button to choose the setting number.

⚠ Now the setting value is flashing!

**NOTE** Setting range :  
1 (Darkest) ~ 5 (Brightest), 5 different levels available.  
Setting unit : 20% per level.  
The backlight brightness will change immediately after you set the value.

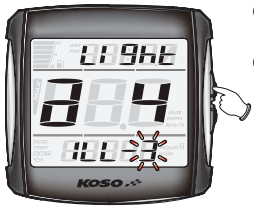

- Press the **Select** button to go back to the backlight brightness setting screen.
- EX. The backlight brightness setting is changed from 5 (100%) to 3 (60%).

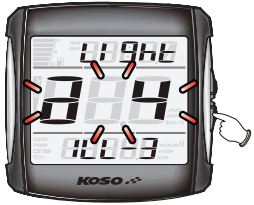

- Press the **Adjust** button to select the Oil maintenance mileage.

#### 4-5 Oil maintenance mileage settings

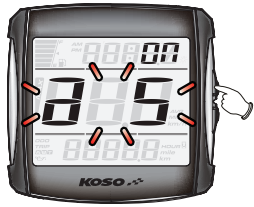

- Press the **Select** button to enter the Oil maintenance mileage setting screen.



- **Example** : To activate the Maintenance Mileage Indication and set the warning value to 500 km.
- Press the **Select** button and notice the Maintenance Mileage Indication is activated.

**NOTE** If you don't want to use this function, then set it as "OFF". When you set "OFF", the Maintenance Mileage indication will not be shown.



- Press the **Select** button to the digit you want to set.

⚠ Now the setting value is flashing!

**NOTE** Setting range : 300 ~ 5,000 km (mile).  
Setting unit : 100 km (mile).

**NOTE** Cursor moving order is : from thousands digit to hundreds digit.

P.S.



- When the oil maintenance mileage returns to zero, the oil change symbol will light up.
- The oil maintenance mileage is counting backwards.

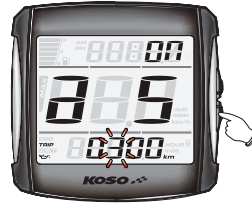

- Press the **Adjust** button to choose the setting number.



- Press the **Select** button 3 times to go back to the Oil maintenance mileage screen.
- EX. The Oil maintenance mileage setting is changed from 300 to 500 km.

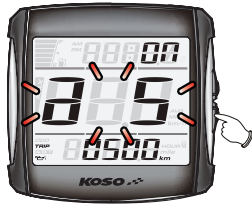

- Press the **Adjust** button to select the Odometer setting.

#### 4-6 Odometer settings



- Press the **Select** button to enter the Odometer setting screen.



- **Example** : To set Total Mileage (ODO) to 15,000km.
- Press the **Select** button to the digit you want to set.

⚠ Now the setting value is flashing!

**NOTE** Setting range : 0 ~ 99,999 km (mile).

**NOTE** Cursor moving order is : From ten thousands digit, thousands digit, hundreds digit, tens digit then to the units digit.



- Press the **Adjust** button to choose the setting number.





- Press the **Select button** to go back to the Internal ODO display screen.
- EX. The Odometer setting is changed from 0 to 15,000 km.



- Press the **Select button for 3 seconds** to go back to the main screen.
- EX. Internal ODO setting is 12,500 km.

#### 4-7 Internal ODO settings

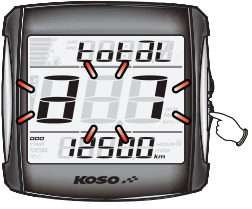

- Press the **Adjust button** to enter the Internal ODO screen.



- The main screen.

### 5 Trouble shooting

The following situation does not necessarily indicate malfunction of the meter. Check the following points, before taking it in for repairs.

Trouble	Check item	Trouble	Check item
The meter does not work when the power is on.	<ul style="list-style-type: none"> <li>● The meter has no power.               <ul style="list-style-type: none"> <li>→ Make sure the wiring is connected.</li> <li>The wiring and fuse are not broken.</li> <li>→ The battery is broken or the battery is too old to supply enough power (DC 12 V) to make the meter work.</li> </ul> </li> <li>● Check the voltage of your battery, and make sure the voltage is over DC 12 V.</li> <li>● Make sure the speed sensor is connected properly.               <ul style="list-style-type: none"> <li>→ Check if the speed sensor is connected and working properly. Also check whether the speed sensor cable is broken or loose.</li> </ul> </li> <li>● Check the tire-size setting.               <ul style="list-style-type: none"> <li>→ Refer to the manual 4-1 circumference and sensing point settings.</li> </ul> </li> </ul>	<p>The odometer and trip meter are not accumulated or accumulated the wrong data.</p> <p>Fuel gauge does not appear or appears incorrectly.</p> <p>The clock is incorrect.</p>	<ul style="list-style-type: none"> <li>● It is possible that the permanent power wire is not connected properly.               <ul style="list-style-type: none"> <li>→ Check if the red positive wire is connect properly.</li> </ul> </li> <li>● Check your fuel tank.</li> <li>● Check the wiring harness.               <ul style="list-style-type: none"> <li>→ Is the wire connected properly?</li> </ul> </li> <li>● Check the tire-size setting.               <ul style="list-style-type: none"> <li>→ Refer to the manual 4-2 fuel gauge resistance settings.</li> </ul> </li> <li>● Did you connect the wires correctly?               <ul style="list-style-type: none"> <li>→ Check if the positive wire (Red) connected to the battery, and the main positive wire (Brown) connected to the main switch.</li> </ul> </li> </ul>
<p>The meter shows the wrong information.</p> <p>Speed does not appear or appears incorrectly.</p>			

\* If the problem is not resolved after following the steps shown above, please contact your local distributor for assistance.