



Thank you for purchasing our product. Before installing/operating the product, read the instructions carefully and retain them for future reference.

⚠ Attention!

- For installation, follow the steps described. Any damage caused by wrong installation shall be imputed to the users.
- To avoid a short circuit from occurring do not pull or modify the wires during installation.
- Do not disassemble or change any parts. Opening and disassembling this unit will void any warranty.
- Maintenance and repairs should be executed by our professionals only.

NOTE

⚠ Some procedures must be followed to avoid damages to the product.

⚠ **WARNING!** Certain procedure must be followed to avoid damages to yourself, to the vehicle or to others.

1 Accessories

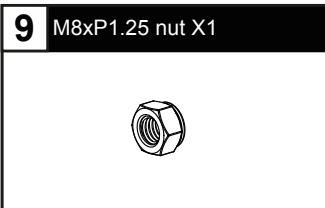
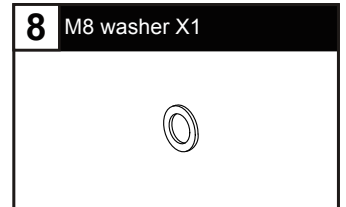
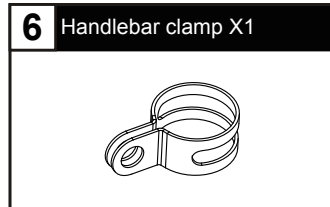
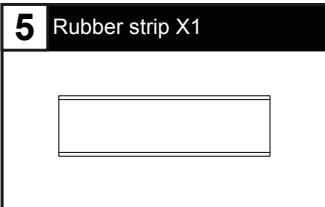
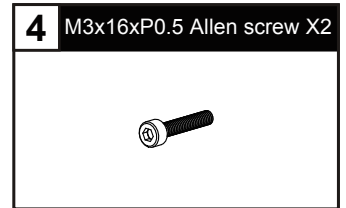
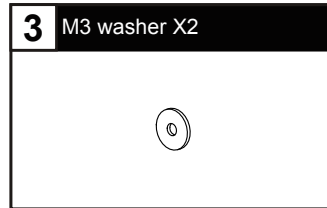
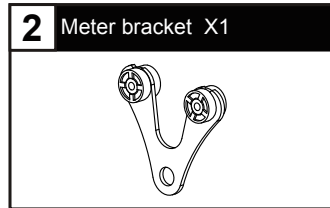
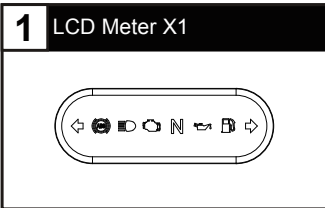

2 Wiring Installation Instructions

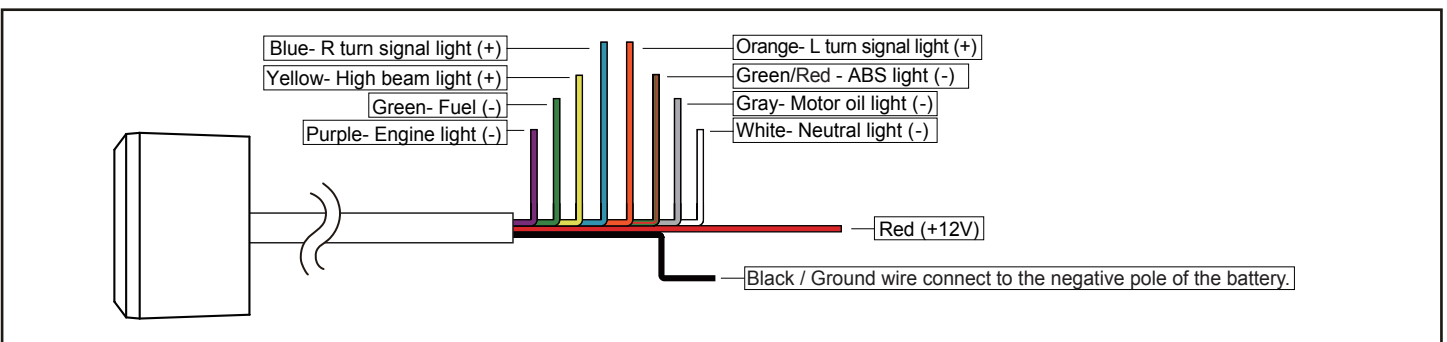

3 Installation instructions

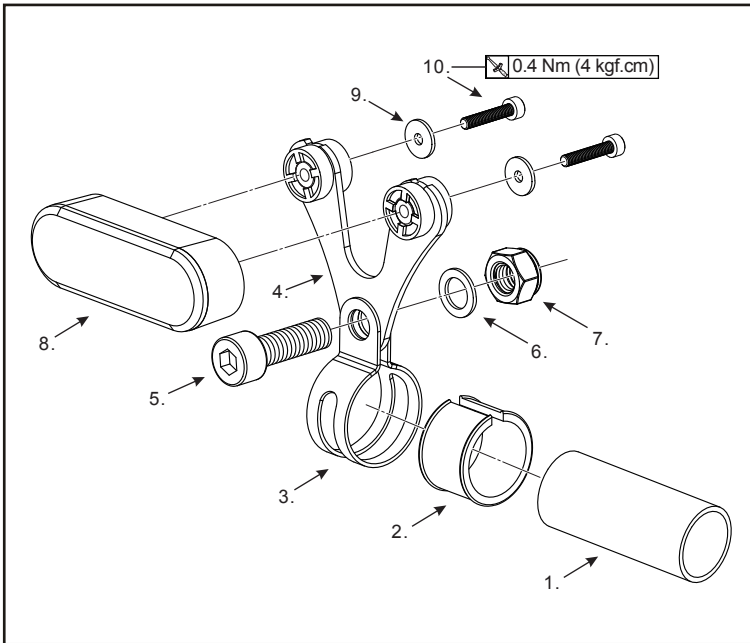

Follow the steps below during installation.

1. Handlebar
2. Rubber strip (Accessory 5)

CAUTION! Refer to the list below and decide whether to use rubber strip according to the handlebar diameter.

Handle bar SIZE	Use Rubber strip
7/8"(22.2 mm)	NO
1"(25.4 mm)	YES

3. Handlebar clamp (Accessory 6)
4. Meter bracket (Accessory 2)
5. M8x20LxP1.25 Allen screw (Accessory 7)
6. M8 washer (Accessory 8)
7. M8xP1.25 nut (Accessory 9)
8. LCD Meter (Accessory 1)
9. M3 washer X2 (Accessory 3)
10. M3x16xP0.5 Allen screw X2 (Accessory 4)

4 Meter Size

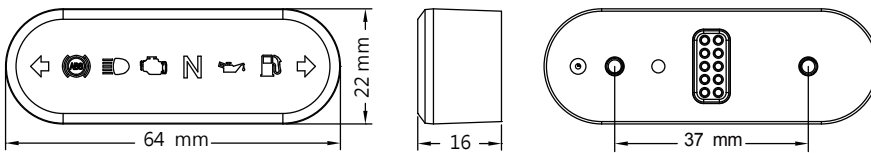

5 Trouble Shooting

The following situations do not necessarily indicate malfunction of the product. Check the following points before contacting us.

Trouble	Check item
The meter indicator didn't display.	<ul style="list-style-type: none"> ●The power isn't supplied to the meter. →Make sure the wiring is connected. The wiring and fuse are not broken. →The battery is too old to supply needed power (DC 12 V).

※ If the problems still can't be solved, contact our technical department for assistance.