



Part No. 2321-0070

MEM8979

REVISION 072513

**Suzuki C50, C50T
MS Batwing Fairing, Memphis Fats/Slim
Mounting Kit**

**C50T application requires 2321-0169 Turn
Signal Relocation Kit (not included)**

Before assembly, read Warnings inside



WARNING

1. During installation, make sure that the fairing / windshield and hardware do not interfere with any cables or wiring when the forks are turned all the way in either direction. Also make sure, through the full range of adjustment, that the fairing / windshield and hardware do not hit the gas tank.
2. This is a detachable fairing / windshield, ALWAYS make sure the locking mechanism is fully engaged after installing the fairing / windshield.
3. The improper installation of this kit and related components could result in serious injury or death.



CAUTION

1. Memphis Shades fairing / windshields are made from Lucite® acrylic, and will last for years with proper care. Clean your fairing / windshield with plenty of soapy water (mild dishwashing liquid is best) and a soft cotton cloth. Use your bare hands to feel and dislodge bugs, or cover with a wet, soapy towel and let it soak. Don't use paper towels and scrape with anything. Small scratches can be removed with NOVUS #2.
2. Never use any glass cleaning products, petroleum based chemicals, or cleaning agents with ammonia, bleach or any other harsh chemicals. This includes (but not limited to) RainX, brake fluid, acetone, paint thinner, benzene and gasoline. "If it hurts your nose, it will hurt the plastic."
3. Glass cleansing agents will cause severe damage to your fairing / windshield, and will void your warranty.
4. At certain times of the day the Sunlight can reflect off the curvature of a fairing / windshield and cause extreme heat build-up on motorcycle instruments and instrument panel. Take care when parking. Park facing the sun, place an opaque object over the instruments or adjust the fairing / windshield to avoid reflections.

1. Kit Contents

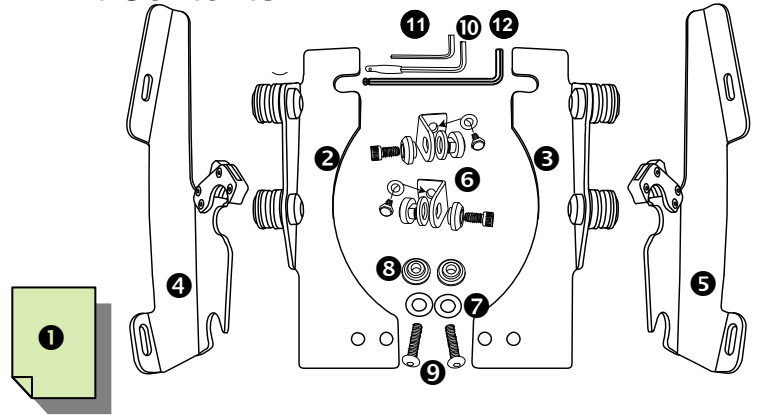

Re	Code	Description	Qty
1	I8979	Mounting instructions	1
2	M1178	Throttle side bracket assembly	1
3	M1179	Clutch side bracket assembly	1
4	M1182	Throttle side mounting plate assembly	1
5	M1183	Clutch side mounting plate assembly	1
6	M780	Upper bracket assembly	2
7	M321	5/16" SS Flat washer	2
8	M568	7/8" Beveled shoulder spacer	2
9	R353	8mm x 25mm Button head cap screw	2
10	M310	3/16" Short arm allen wrench	1
11	M372	3mm Allen wrench	1
12	R354	6mm Ball end long allen wrench	1

2. Mounting Instructions

Additional tools required that are not included in this kit. 7/16" or 11mm Wrench and 13mm wrench.

1. Cover gas tank and front fender with towels to avoid damage during installation.

2. Install the Mountings plates **4 5** onto the Fairing using the washers and acorn nuts provided. (Fig 1). Install the Mounting plates **4 5** onto the windshield, using the bottom and third bolt up. Leave the nylon washers off. (Fig 1a.)
3. Locate the two cast 8mm holes (not being used) underneath the upper triple tree. Using the new 8mm x 12mm SS Hex Cap Screws and washers (From the Upper bracket assembly **6**), install one L-tab in each hole. Face the L-tabs forward and flush with the front of the upper triple tree and loosely tighten (Fig. 2)

Memphis Shades warrants all product components, metal and plastic, against defects in materials and workmanship for 24 months.

For Parts and Warranty Help, Contact:

Memphis Shades, Inc.

P.O. Box 429

Rossville, TN 38066

(901) 853 0293

Visit us on the web at www.memphisshades.com or you can also reach us by email:

customerservice@memphisshades.com

**Suzuki C50, C50T
MS Batwing Fairing, Memphis Fats/Slim
Mounting Kit**

2. Mounting Instructions, continued

Note: For C50T application, see additional mounting instructions included in 2321-0169 Turn signal relocation kit.

4. Remove the turn signal bar cover by removing the Allen bolt located under the turn signal bar cover using the 3mm Allen Wrench **1** . Then **CAREFULLY** pull it straight out and off of the two locator pins. Set it aside in a safe place.
5. Remove the turn signal bar by locating and removing the two green mounting bolts and let the turn signal bar dangle.
6. Install the Clutch side mounting bracket **2** by sliding the top elongated hole into the L-tab bracket, and loosely tighten it. Repeat this step for the Throttle side mounting bracket **2**
7. There are two holes on the lower end of each bracket. . Install the 8mm x 25mm button head cap screw in this order. Place the screw **9** through the washer **7**, through the turn signal bar, through the mounting bracket, then through the aluminum spacer **3** . Insert the screw into the original turn signal bar mounting hole and thread it a few turns. Repeat this step for the other mounting bracket.
8. Slip the Mounting plates **4** **5** into the bushings, adjust height and angle. Now tighten all mounting all bolts. (Fig- 3)
9. Install the turn signal bar cover.

Note: This is a detachable Fairing / Windshield, **ALWAYS** make sure the Locking Mechanism is fully engaged after installation (Fig 4)

Fig. 1

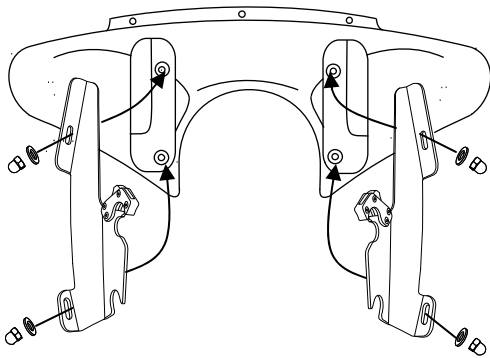

Fig. 1a

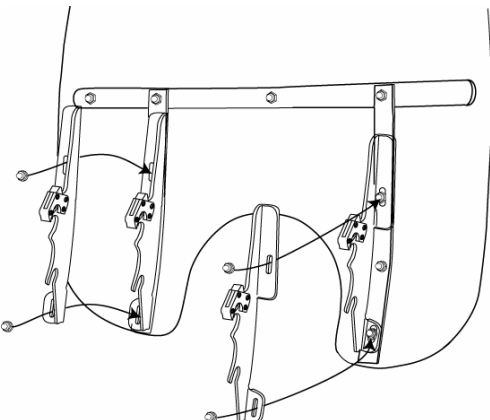

Fig. 2

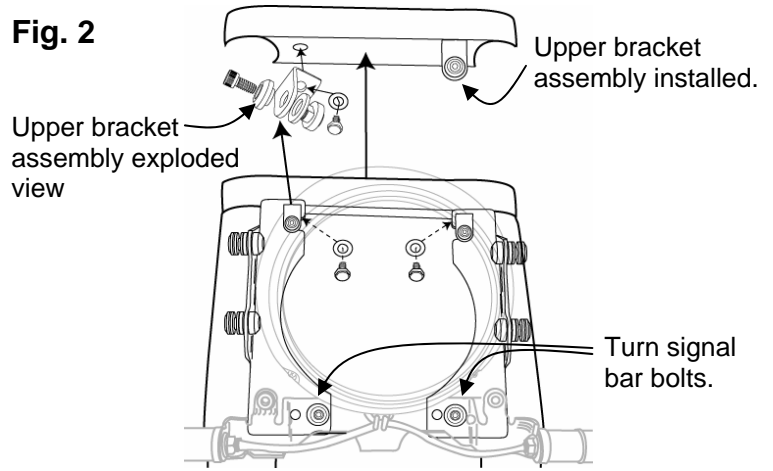

Fig. 3

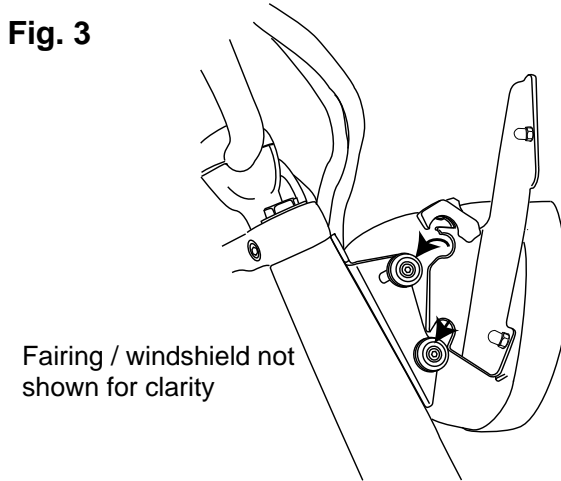
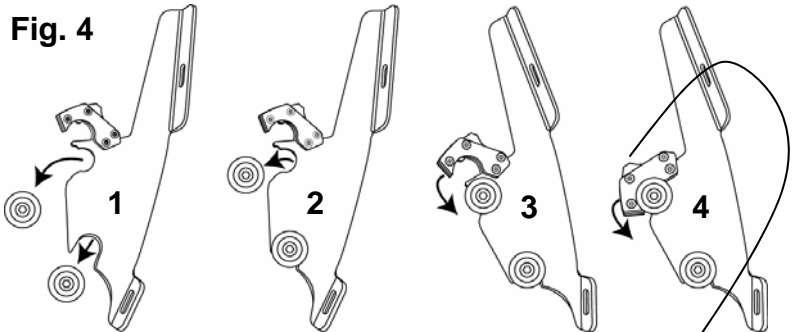
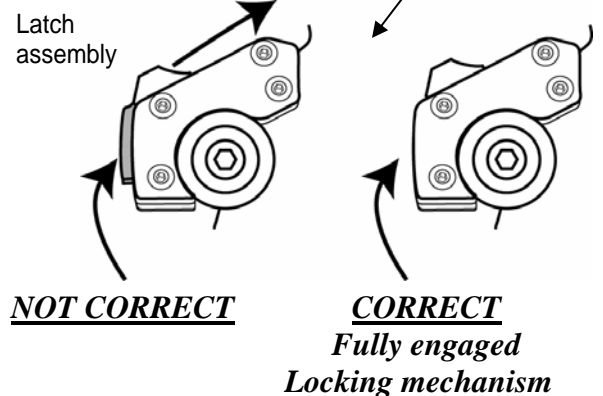

Fig. 4



1. Place lower slot into lower bushing.
2. Rotate top slot into place.
3. Secure locking Mechanism.
4. Loosen Allen Bolt to adjust angle, then re-tighten Allen Bolt.



NOT CORRECT

CORRECT
*Fully engaged
Locking mechanism*