

microSHIFT

Acolyte Rear Derailleur User Manual

ACOLYTE

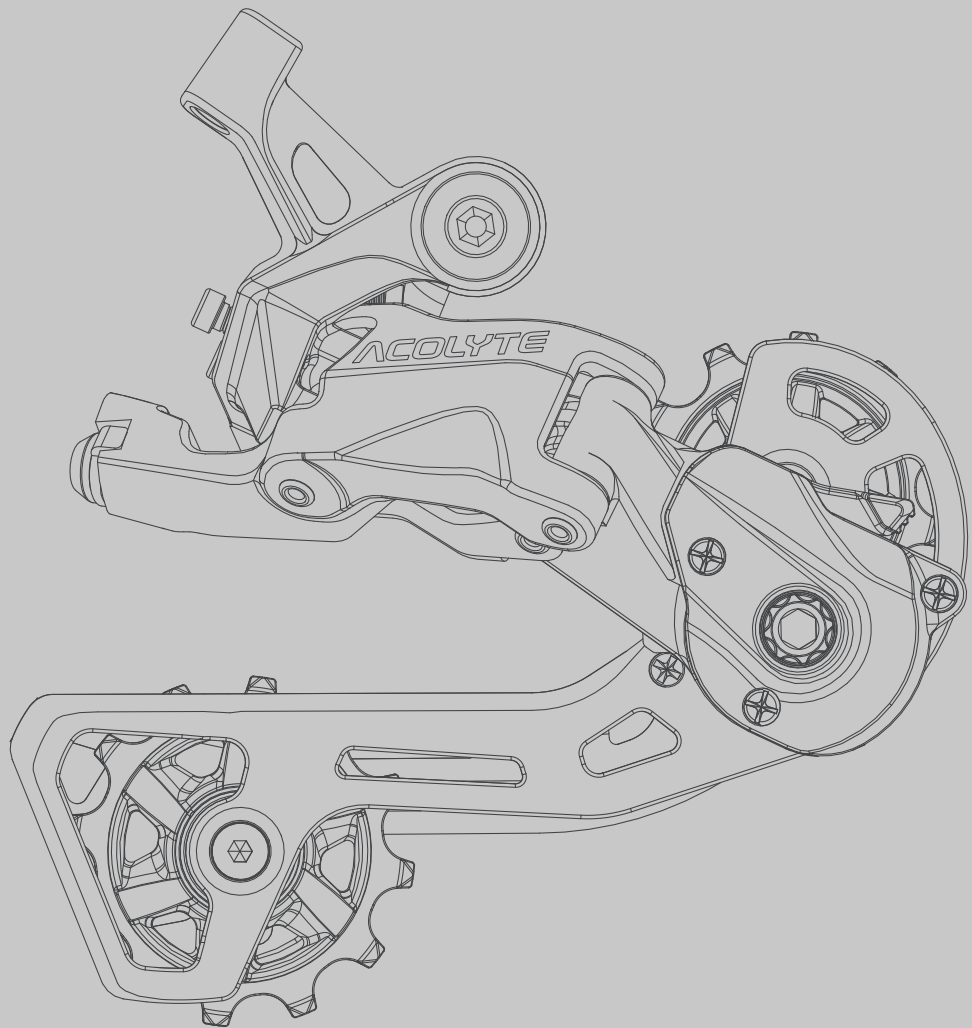

Important Notice



REMINDER

Acolyte derailleurs have a different chain measurement and B-tension adjustment depending on their model.

Acolyte models are identified by the spacing between their pulley wheels.

See **Step 6** and **Step 10** of these instructions for more information.

Version 1:

Medium Cage RD-M5185M = 93mm

Version 2 :

Medium Cage RD-M5185M-B = 75m

Super Short

Short Cage RD-M5185S = 53mm

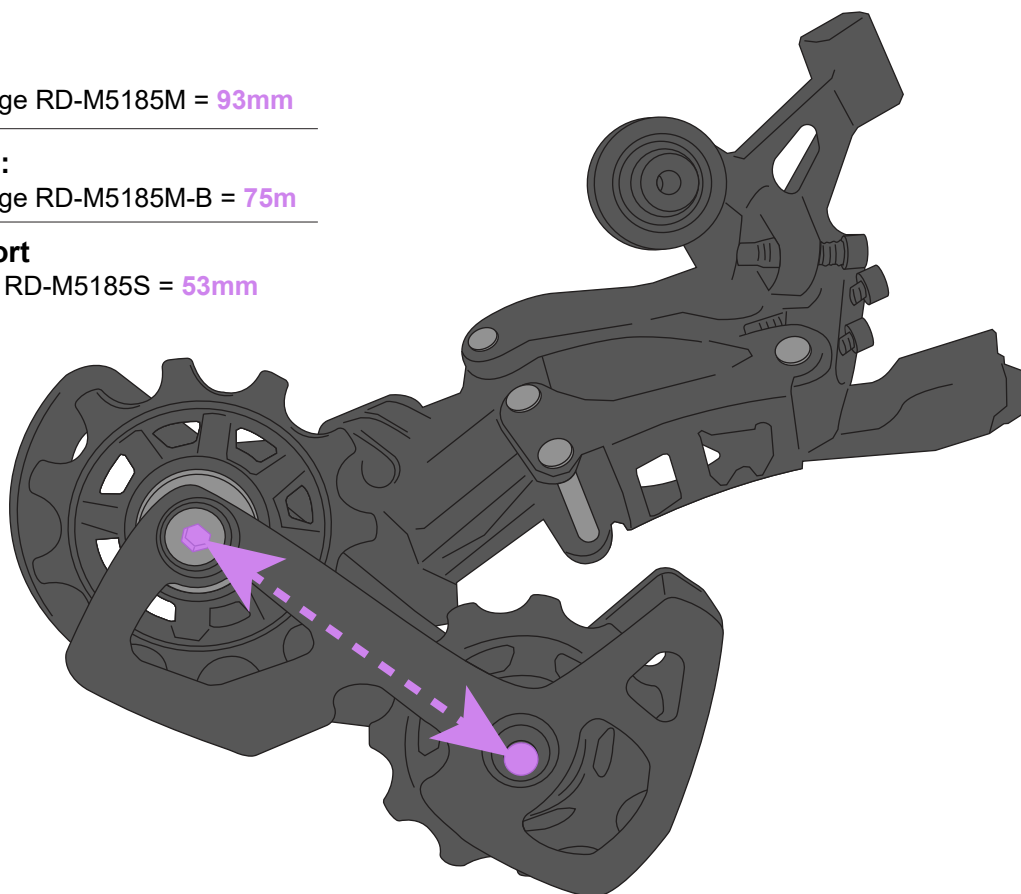

INDEX

Tools and Supplies	3
Rear Derailleur Installation	4
Rear Derailleur Attachment	4
H-Limit Screw Adjustment	6
Proper Cable Housing	7
Cable Installation	9
Disable Clutch	13
Chain Sizing	14
Chain Installation	19
Shifting Adjustment	20
L-Limit Screw Adjustment	22
Tool Identify	24
B-Tension Screw Adjustment	25

Tools and Supplies

1. Torque wrench
2. 4mm & 5mm Hex bits
3. Allen wrenches
4. Chain breaker
5. Cable cutter
6. Tape measurer

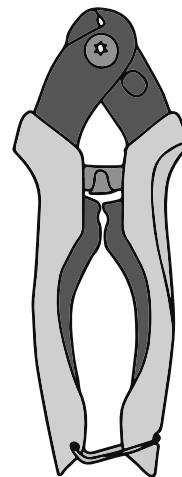
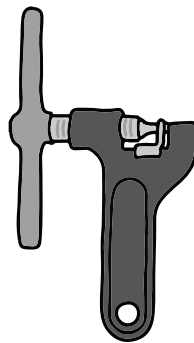
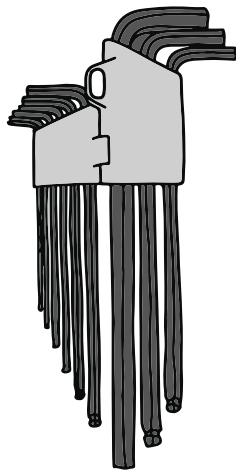
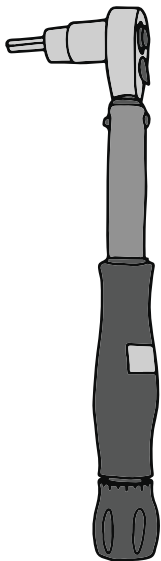

1. Rear Derailleur Attachment

Part I

Attach rear derailleur to the bike. Make sure the **B-tension washer** is above the **derailleur dropout** and engages correctly with the **B-tension adjustment screw**.

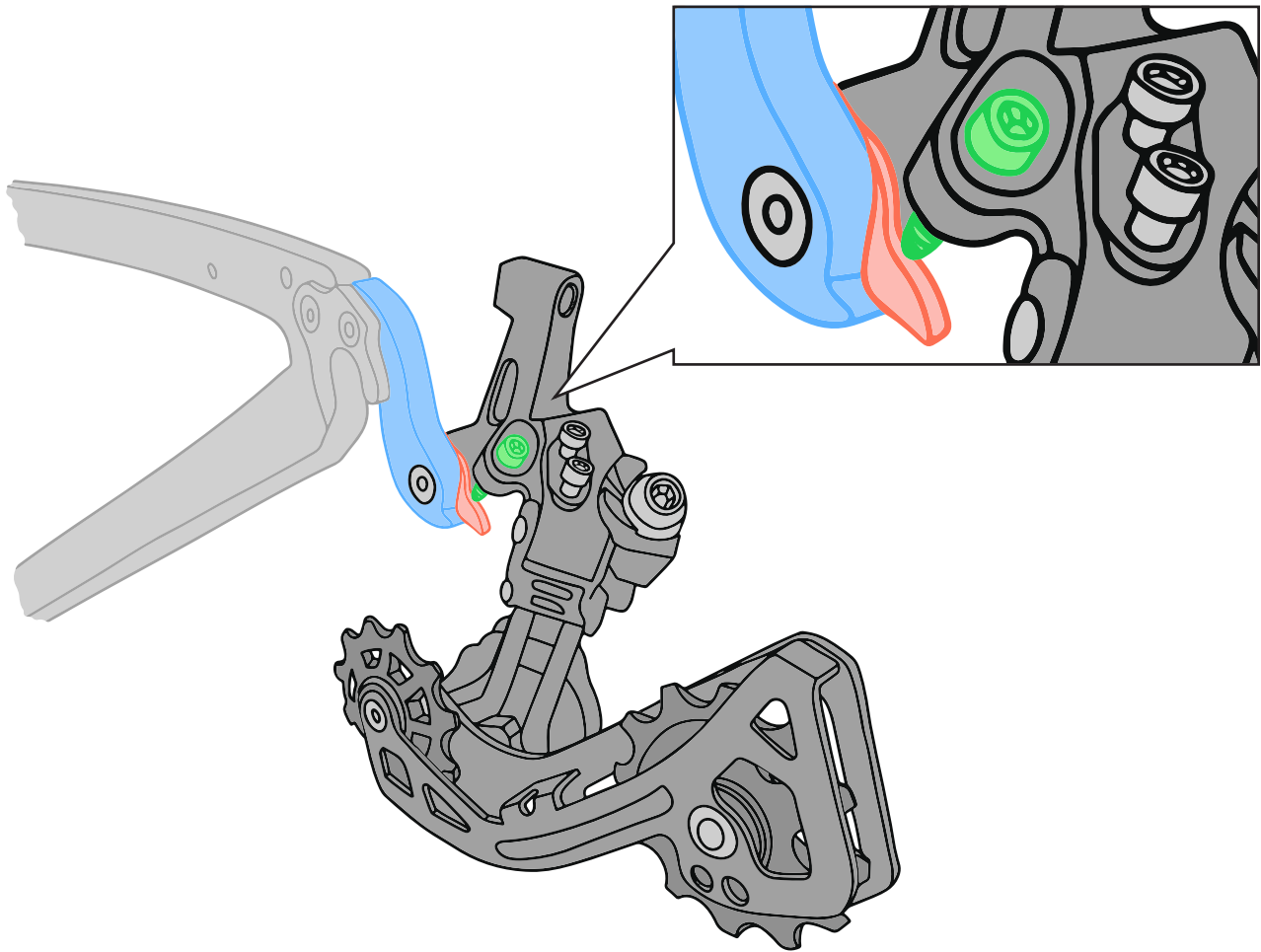

1. Rear Derailleur Attachment

Part II

Tighten the rear derailleur fixing bolt to **8-10 Nm** with a **5mm hex bit torque wrench**. Check to make sure that the derailleur can rotate freely.

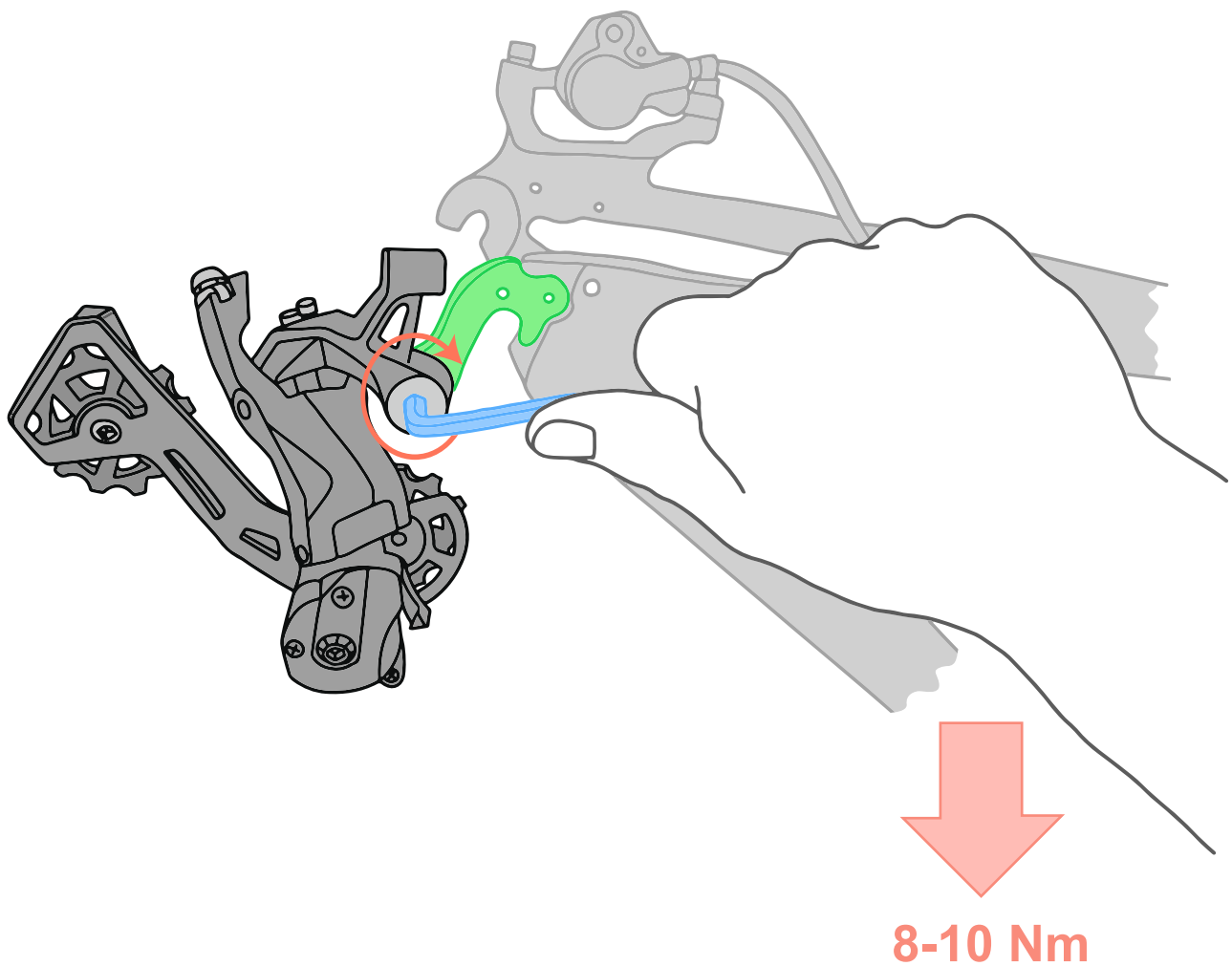

2. H-Limit Screw Adjustment

Adjust the **high-limit screw** until the guide pulley aligns with the outer edge of the smallest cog.

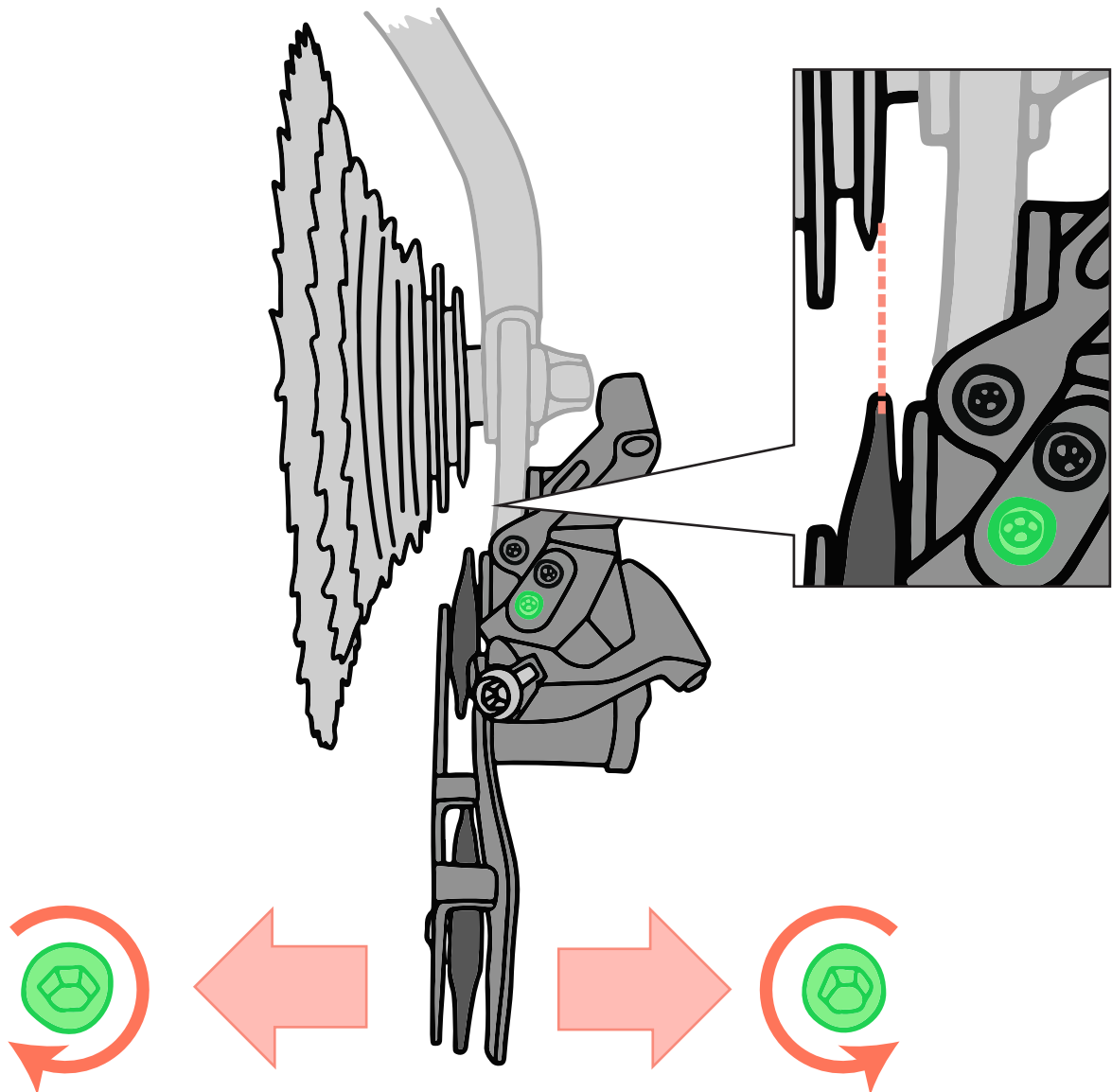

3. Proper Cable Housing

Every frame manufacturer has different cable routing guidelines, so make sure you consult those before cutting the housing. ADVENT works best when there is not too much of a curve in the housing, and not too little slack either. Make sure the end of the housing is sitting against the rear derailleur as well.

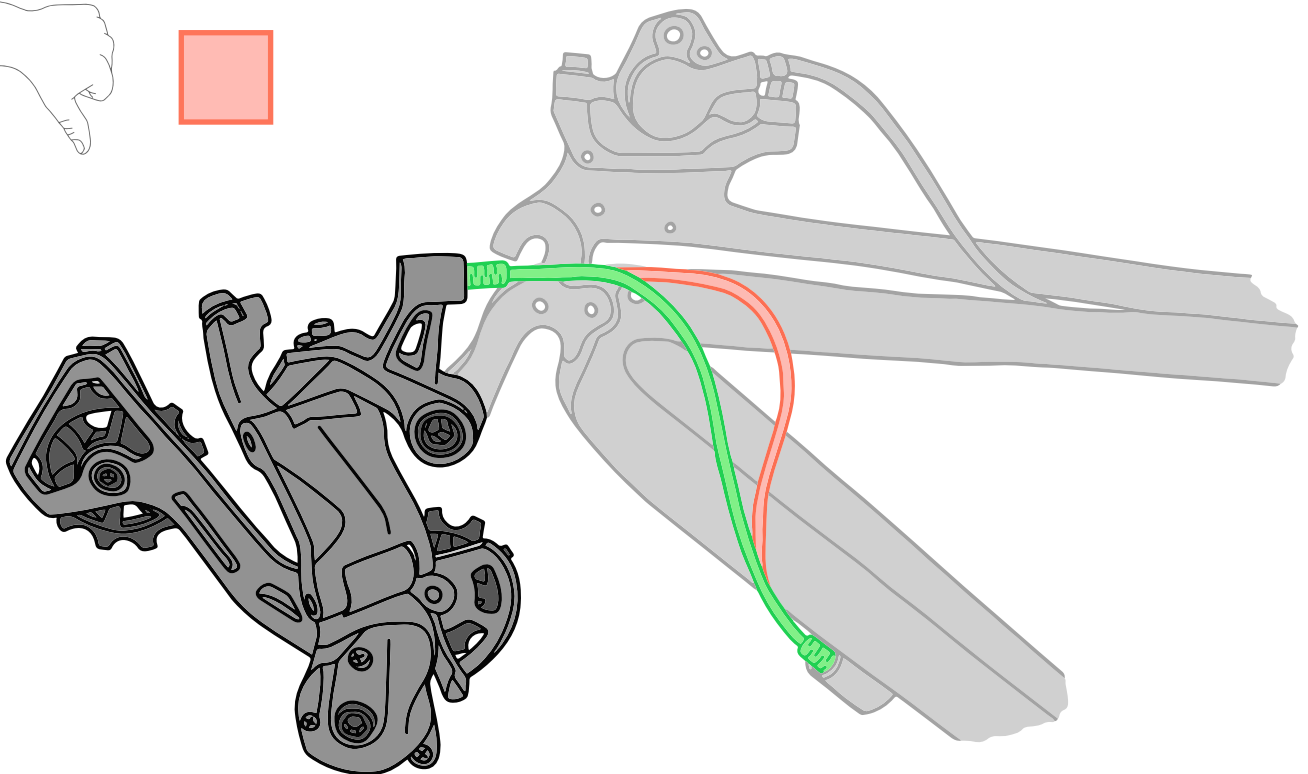

3. Proper Cable Housing

Part II

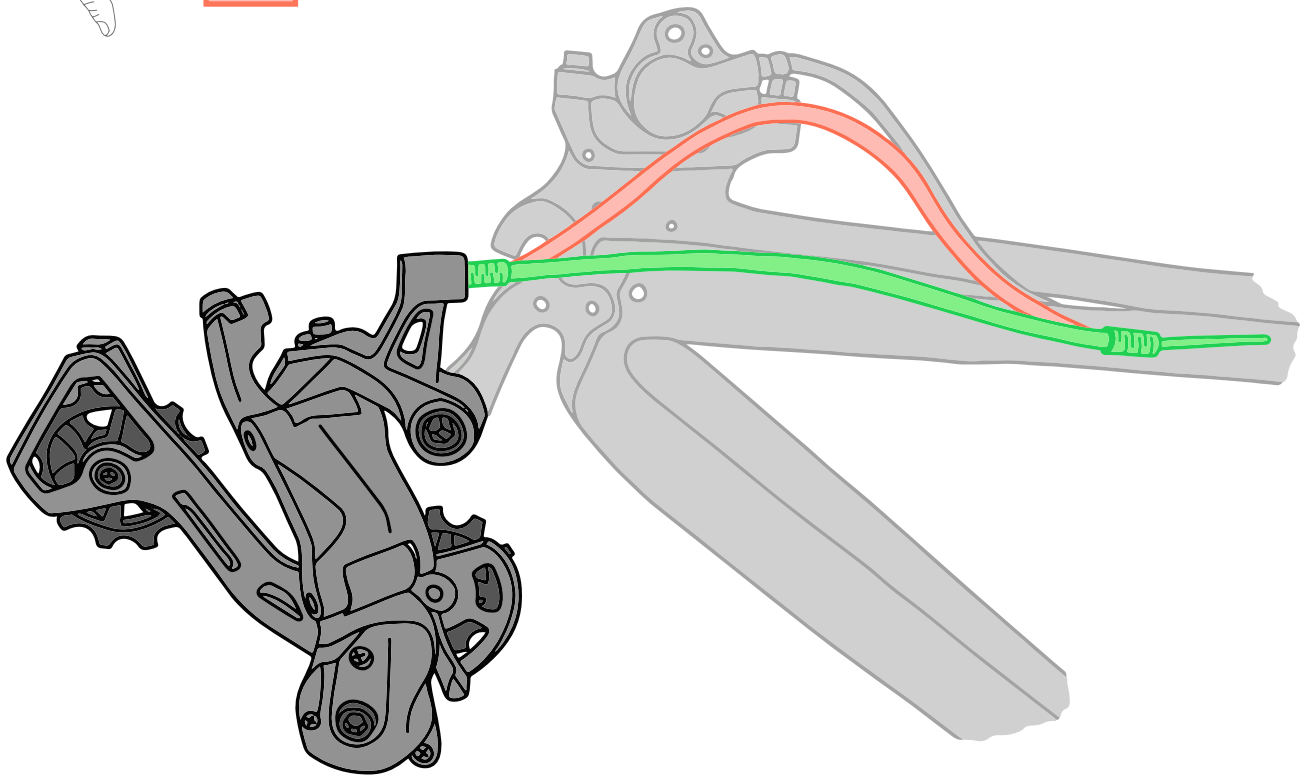
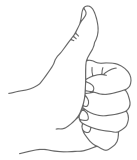

4. Cable Installation

Part I

Before installing the cable, use the **trigger lever** to shift to the highest gear.

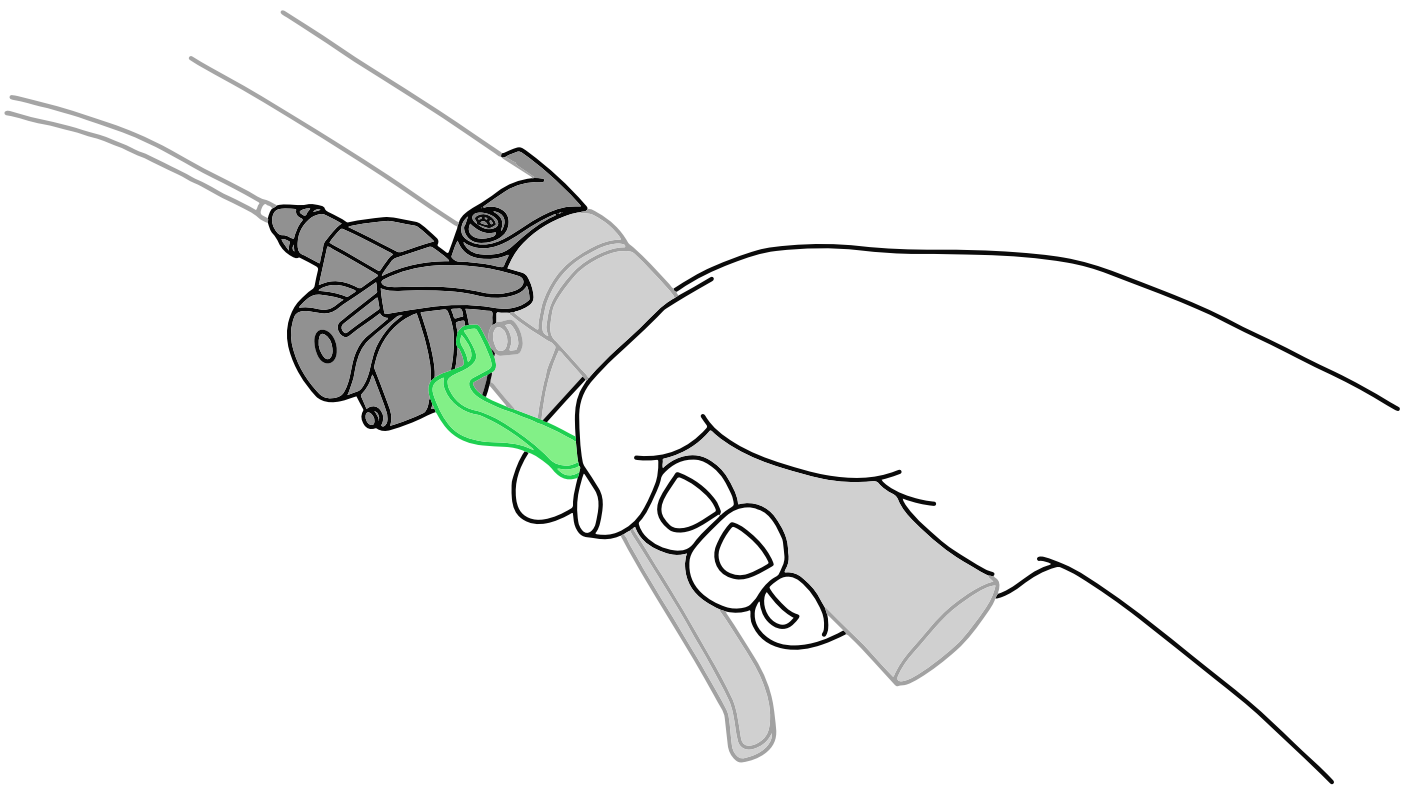

4. Cable Installation

Part II

Route the **cable** through the shifter, housing, and rear derailleur.

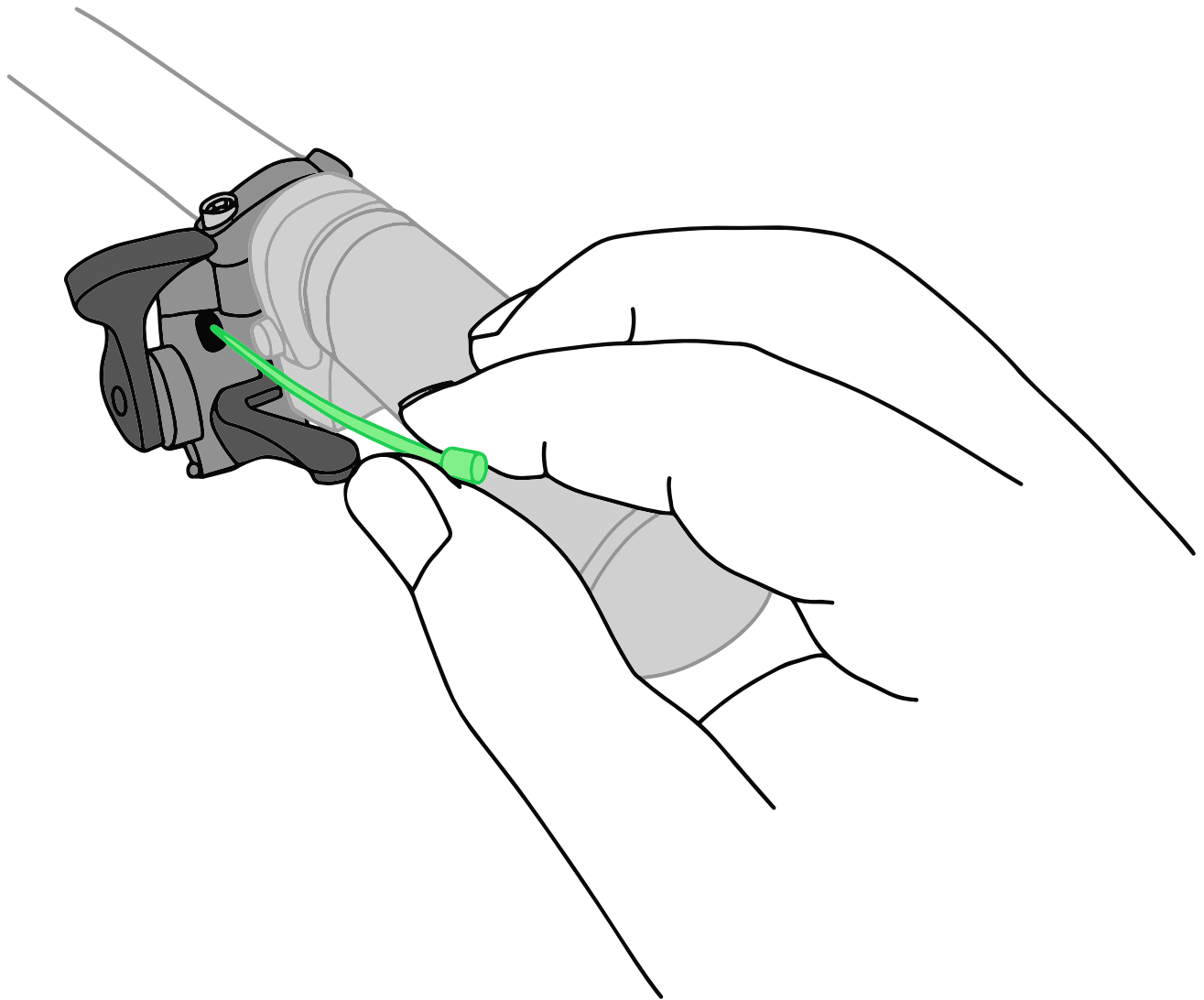

4. Cable Installation

Part III

Route **the cable** underneath the cable fixing bolt and washer. Make sure **the cable** is resting in the groove under the washer. Tighten to **5-7 Nm**.

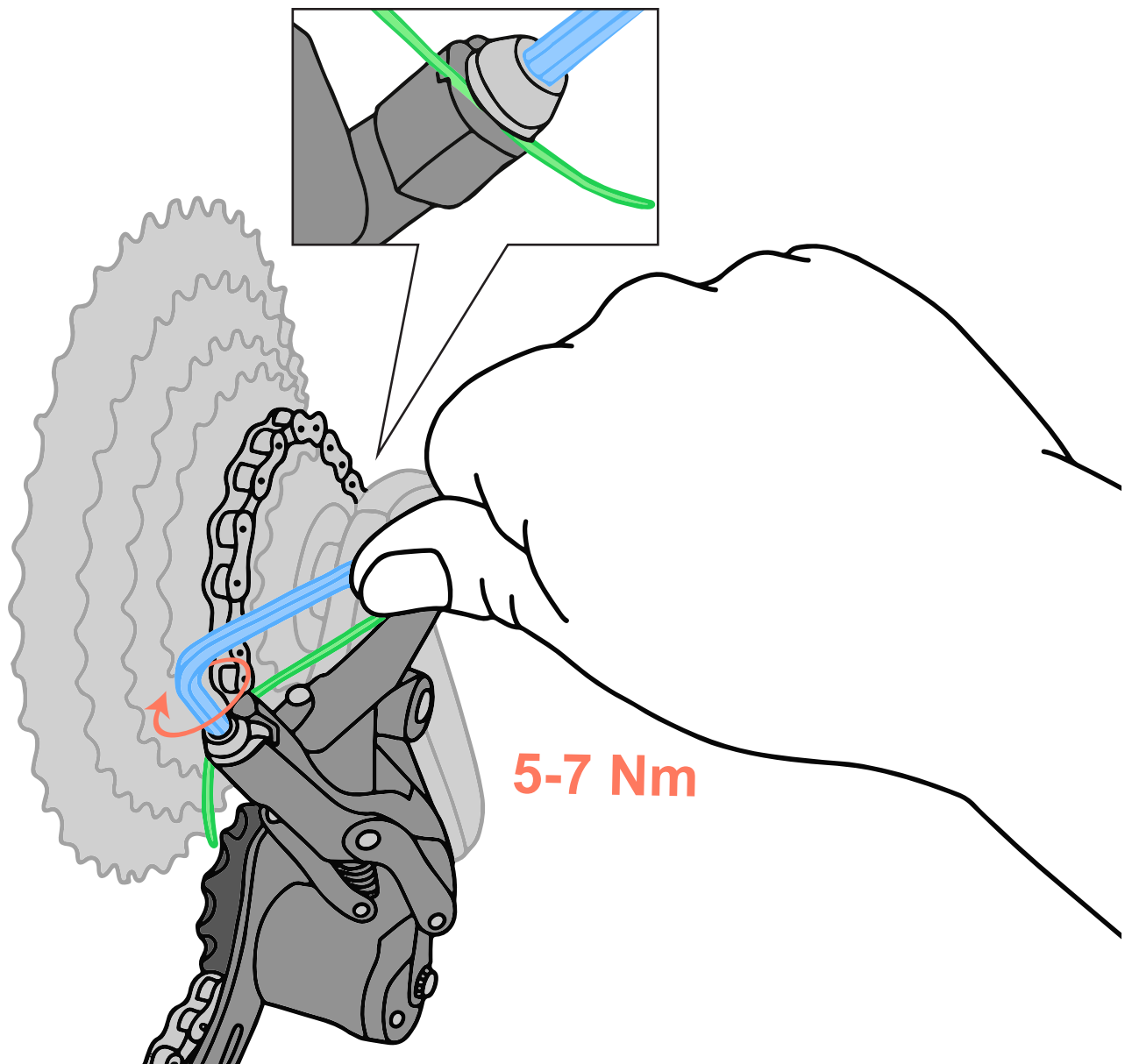

4. Cable Installation

Part IV

Cut the cable and attach the **cable end**.

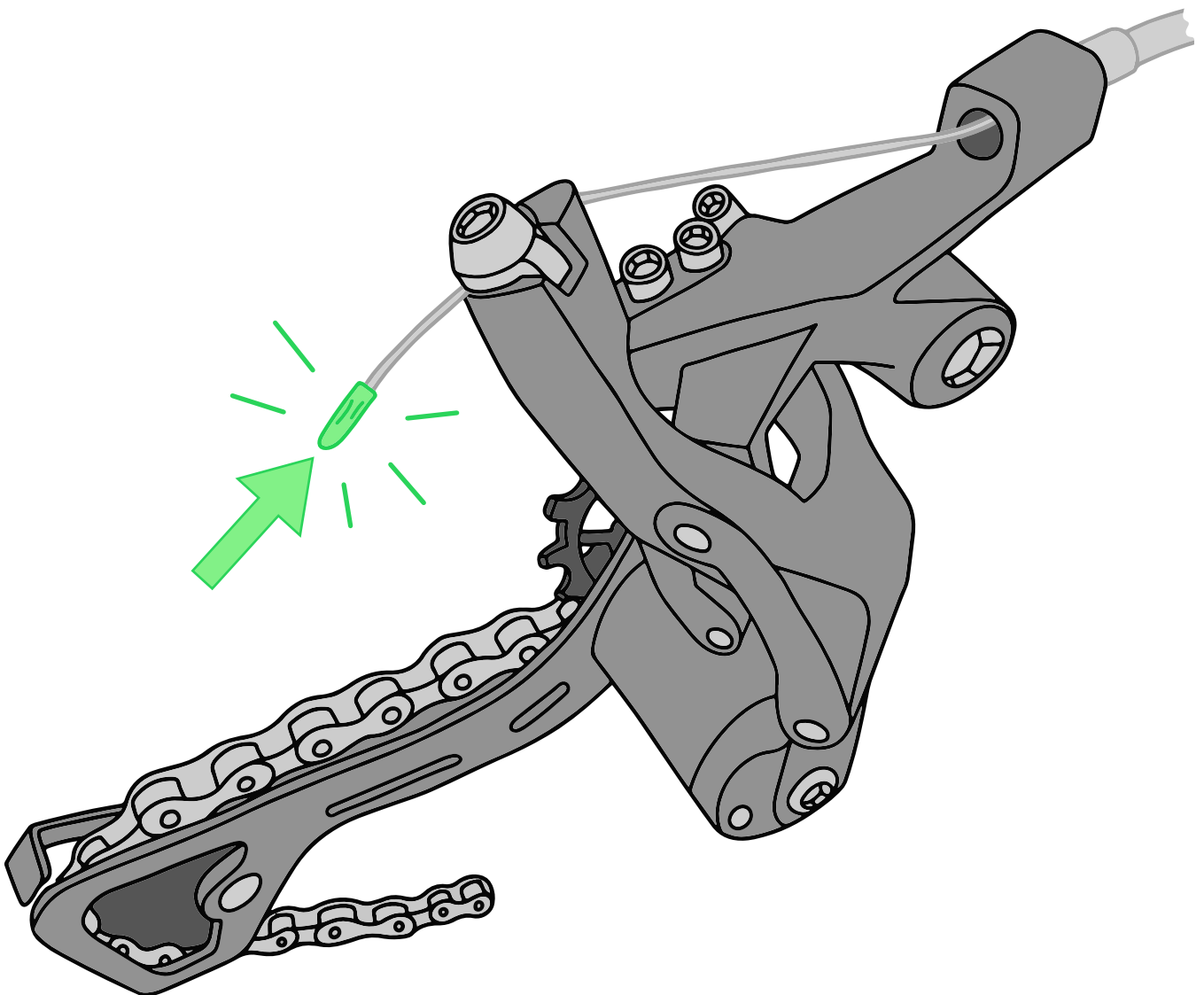

5. Disable Clutch



Clutch Rear Derailleur Only

Make sure SpringLock is disabled before continuing these instructions.
To disable SpringLock, pull the **release lever** toward the front of the bike.

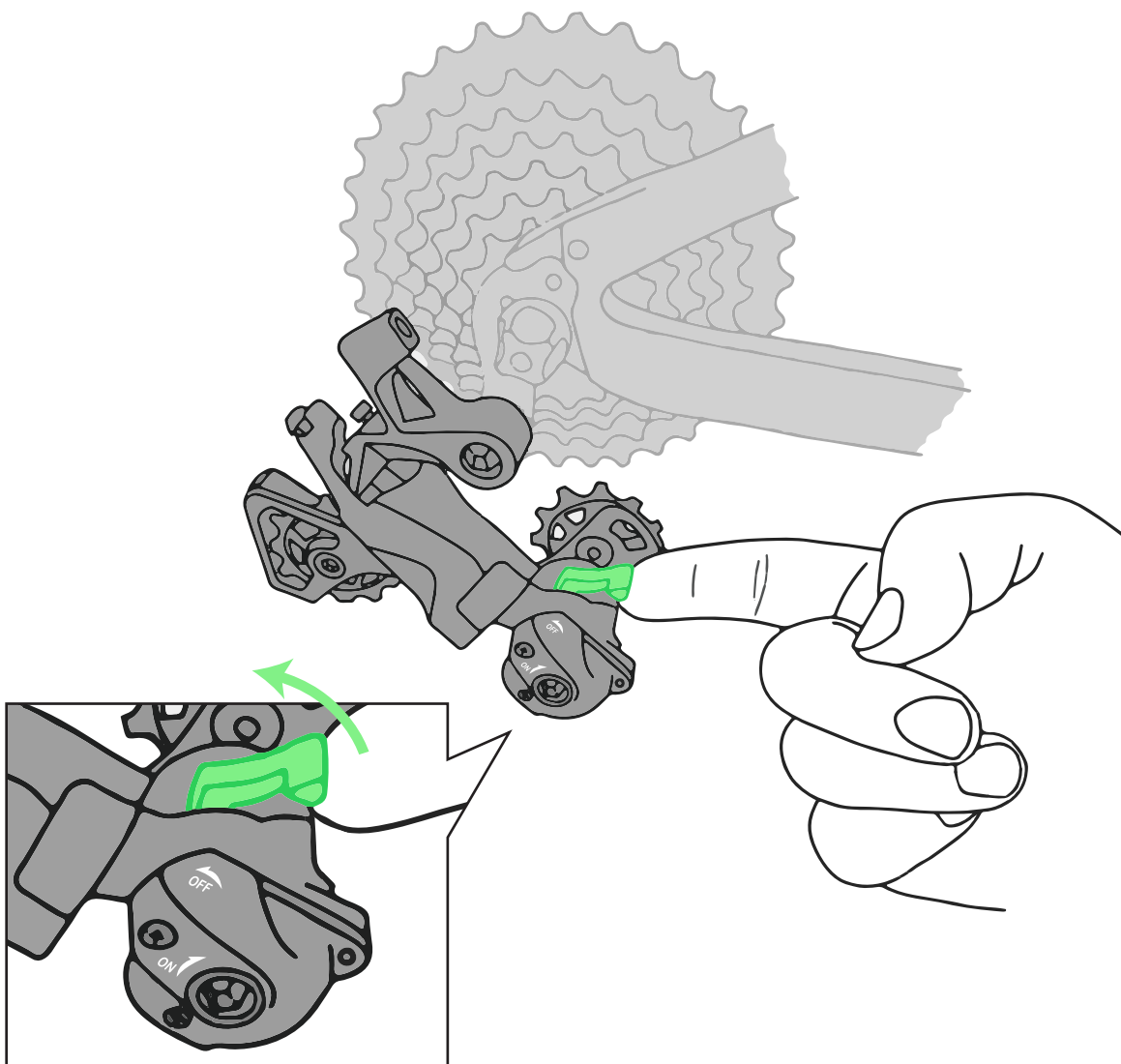



Full Suspension Bike Only

To properly size the chain on a full suspension bike, release air from the rear shock or remove the shock completely.

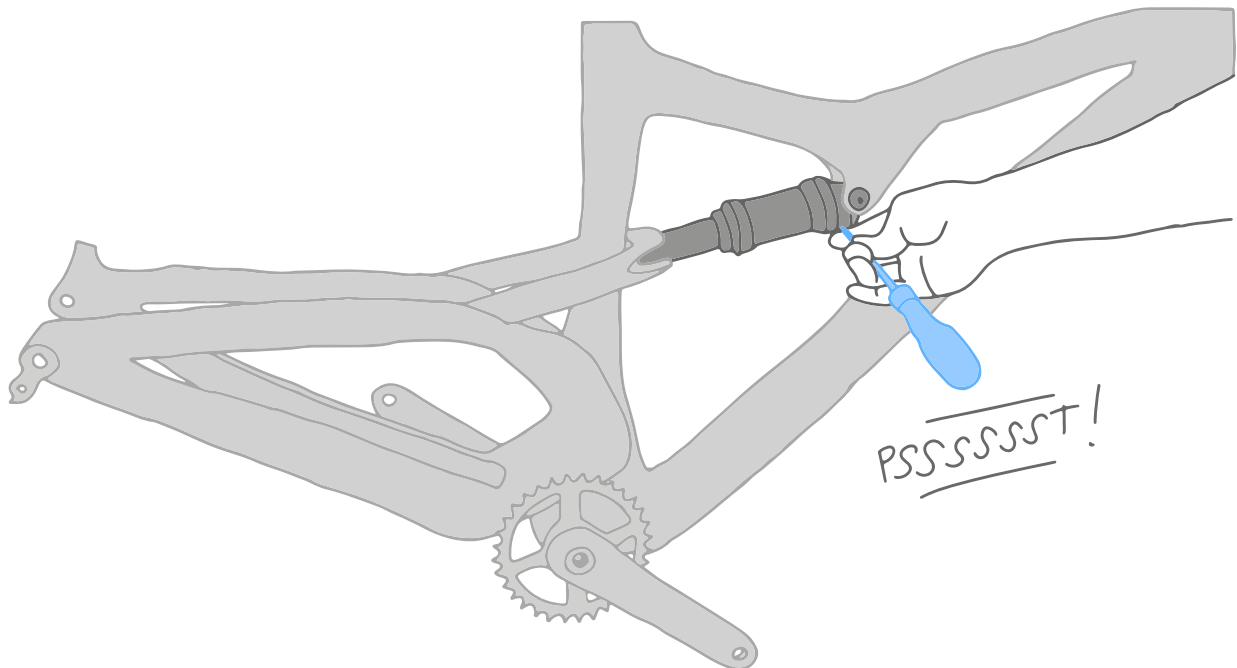



Full Suspension Bike Only

Move the rear axle up and down as you measure the distance between **the bottom bracket** and **the rear axle**. Find the position where they are furthest apart and perform the next step at this position.

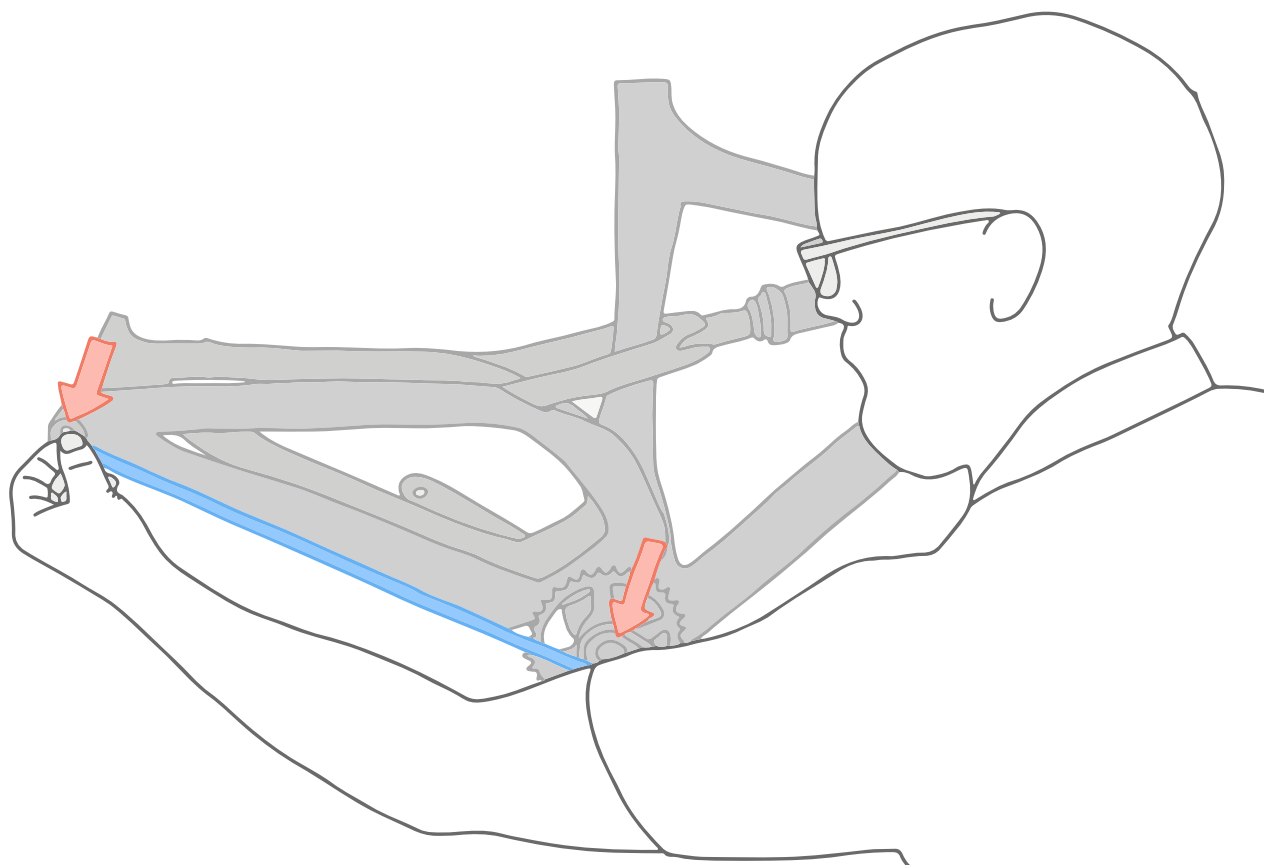

6. Chain Sizing

Part III

Wrap the chain around the chainring and the largest cassette cog without routing through the rear derailleur. Stretch the chain tight.



For chains WITH quick connectors

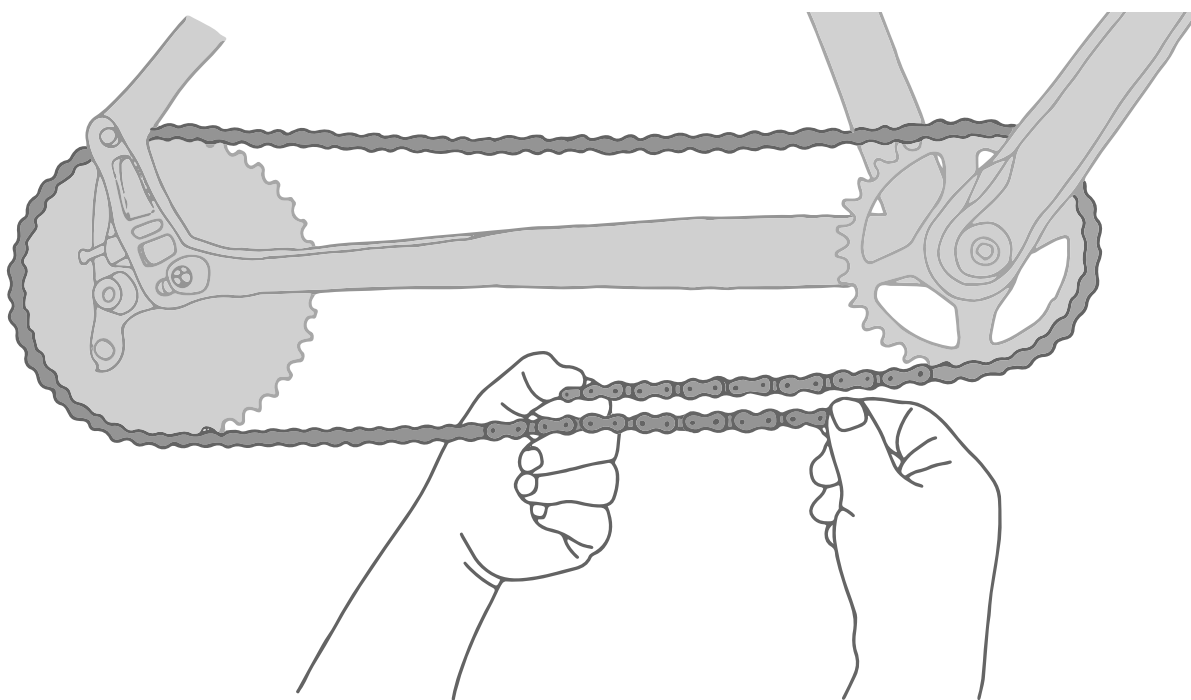

Identify your derailleur version, and size the chain according to cage length. Incorrect chain sizing may damage the products or cause poor shifting performance.

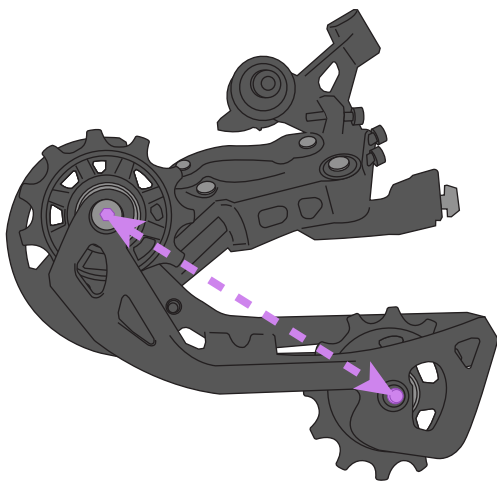

Version 1: 93mm, 102mm

For **Version 1** derailleurs , place **two inner links** next to each other, add **two** inner links and **cut the chain there**.

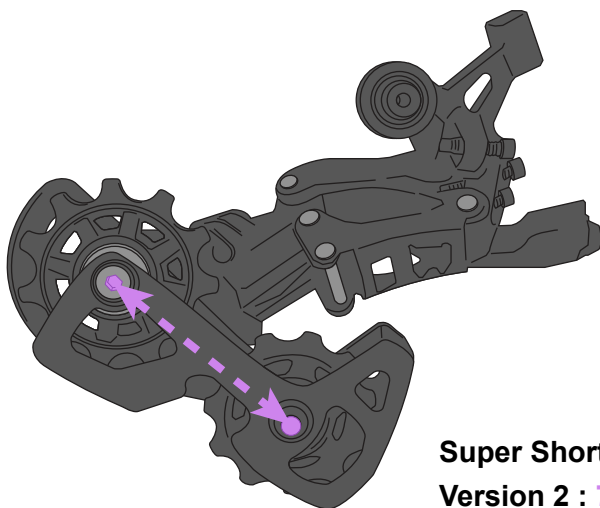
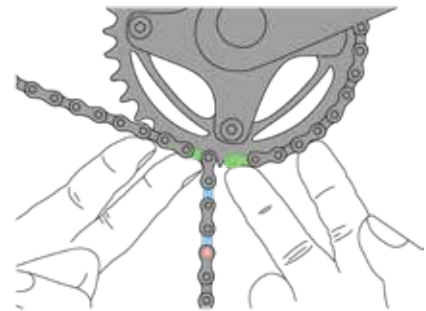

Super Short: 53mm
Version 2 : 75mm

For **Super Short** and **Version 2** derailleurs, place **two inner links** next to each other, add **one** extra inner link and **cut the chain there**.



7. Chain Installation

Route **the chain** over the smallest cog, in front of the guide pulley, **behind the derailment prevention plate**, and behind the tension pulley. Wrap the chain around the chainring and connect the chain according to the chain manufacturer's instruction manual.

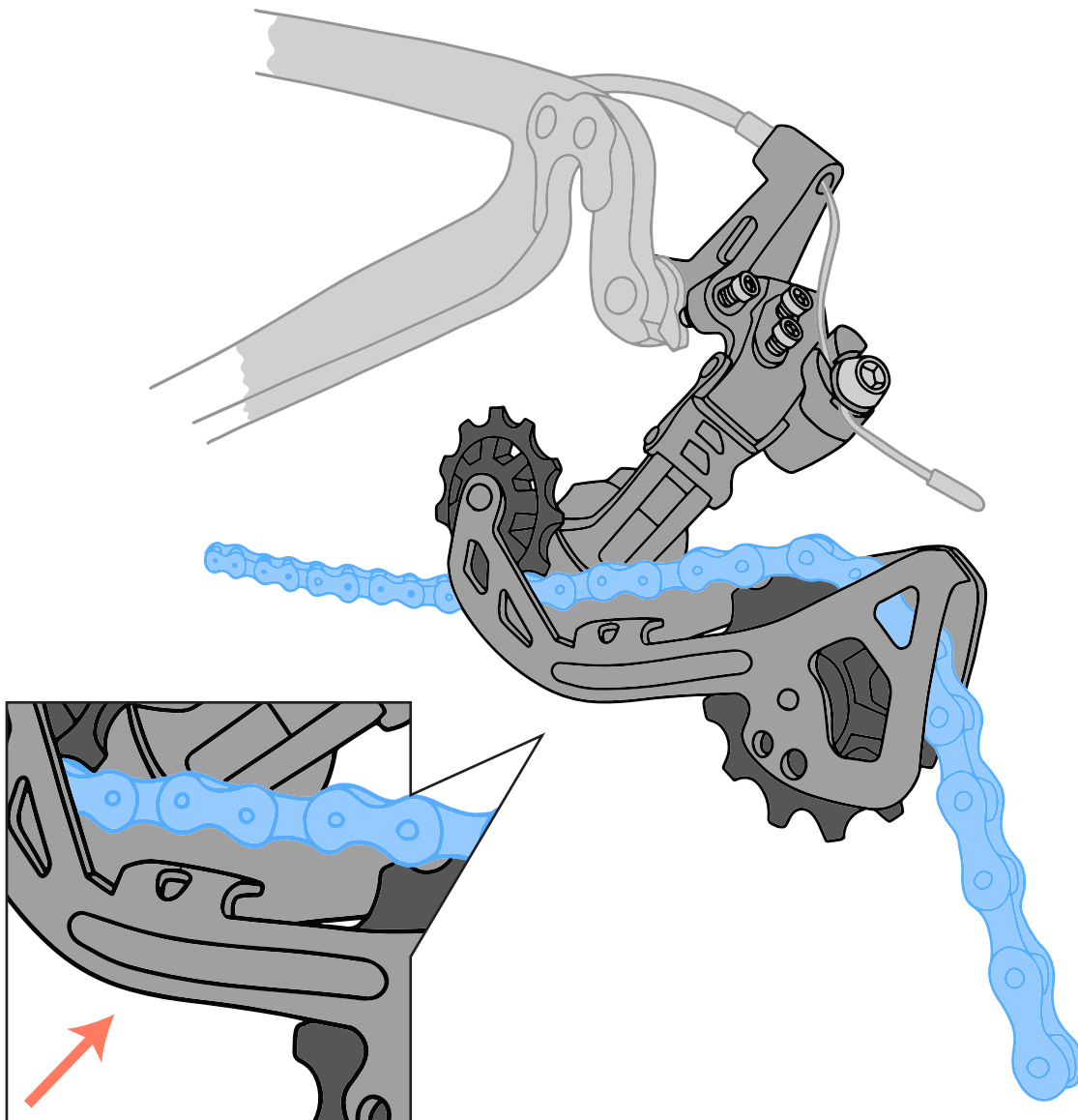

8. Shifting Adjustment

Part I



Clutch Rear Derailleur Only

Before adjusting the shifting, enable SpringLock by turning the **5mm SpringLock bolt** clockwise with a **hex wrench** until there's an audible click.

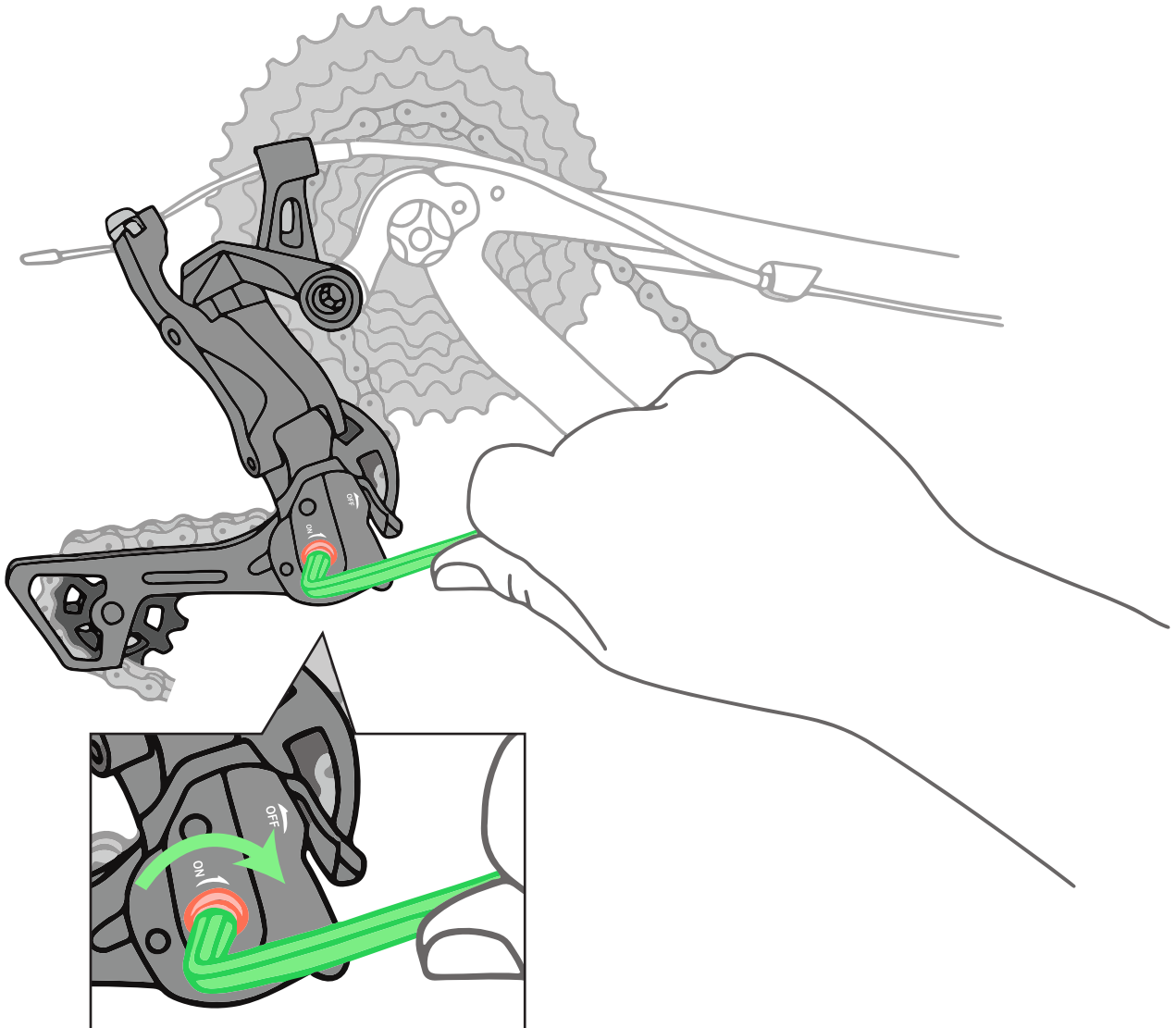

8. Shifting Adjustment

Part II

Shift from the smallest cog to the 2nd smallest cog by pressing the **lower thumb trigger lever** on the shifter. If the chain doesn't move, turn the **barrel adjuster** on the shifter counter-clockwise. Repeat until the derailleur shifts to the 2nd smallest cog.

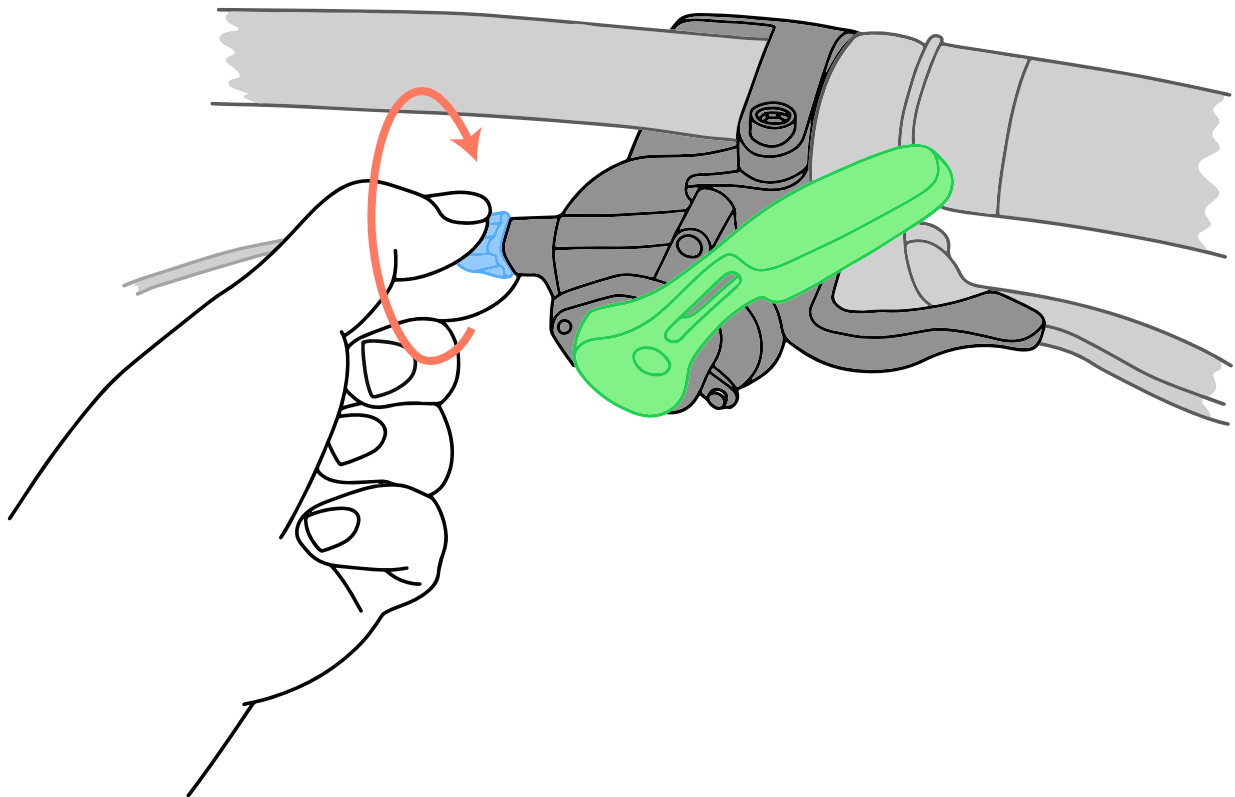

8. Shifting Adjustment

Now make several shifts up and down the cassette. If shifting is slow to move to a larger cog, turn the **barrel adjuster** counter-clockwise. If the shifting is slow to move to a smaller cog, turn the **barrel adjuster** clockwise.

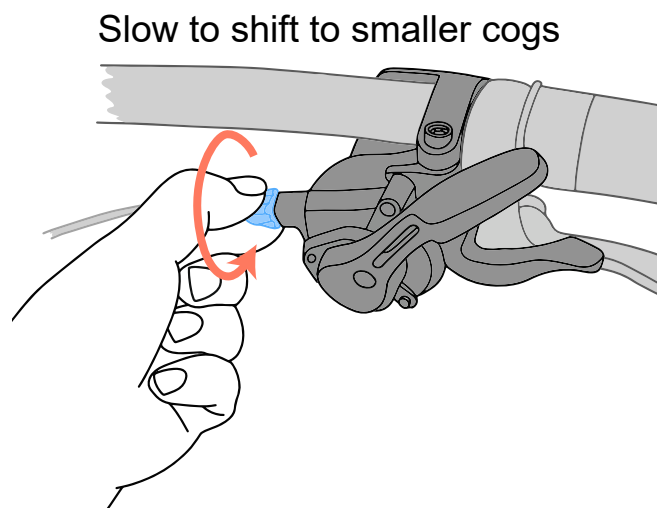
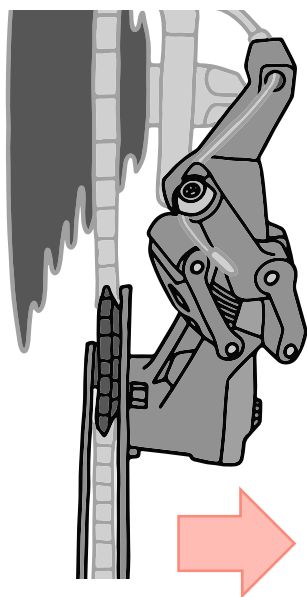
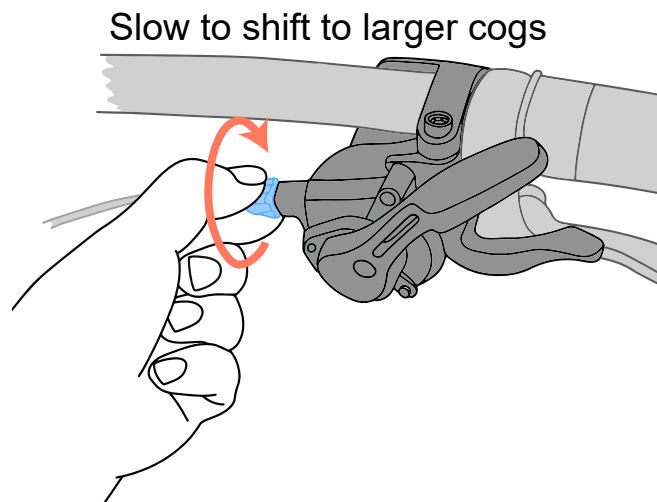
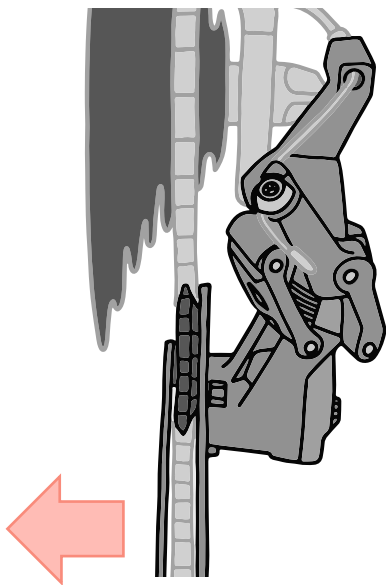

9. L-Limit Screw Adjustment

Part I

Shift to the largest cog on the cassette. Using your hand, try to push the rear derailleur past the largest cog. If the derailleur can move past the cog, adjust the low limit screw.

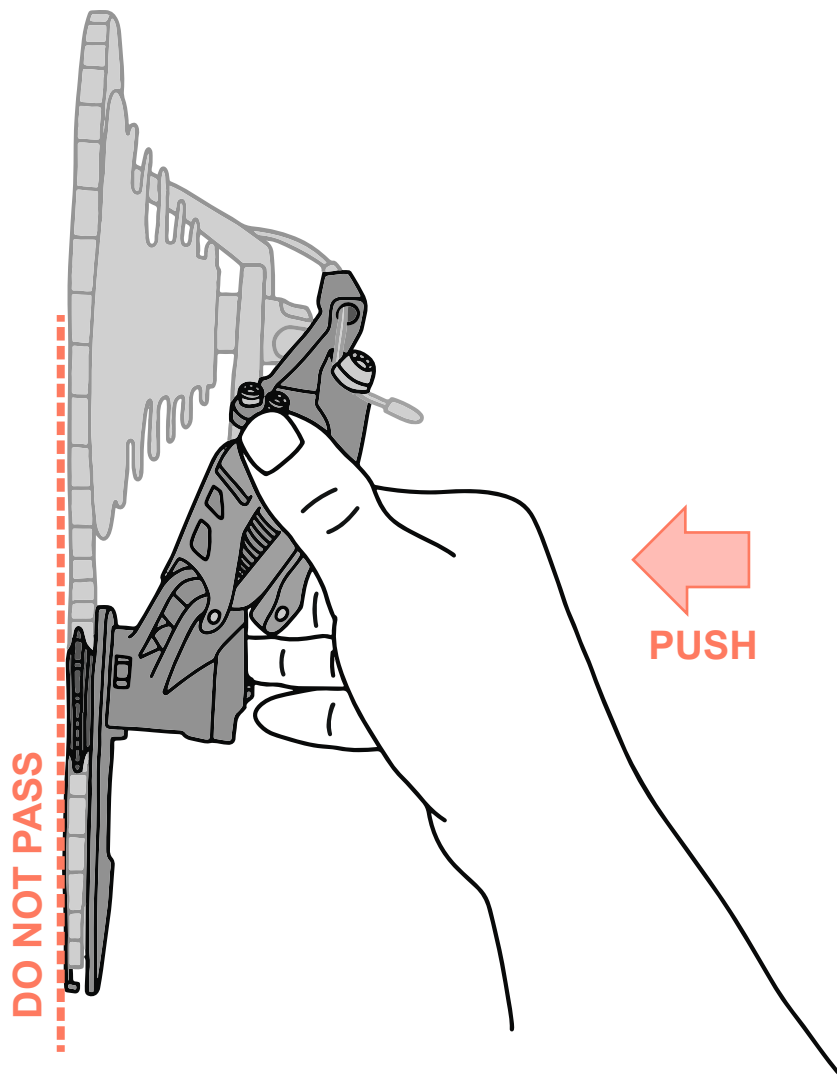

9. L-Limit Screw Adjustment

Part II

Tighten the **low limit screw** until you can't move the derailleur past the largest cog. Shift down and back up to the largest cog. If it is slow to shift to the largest cog, loosen the **low limit screw**.

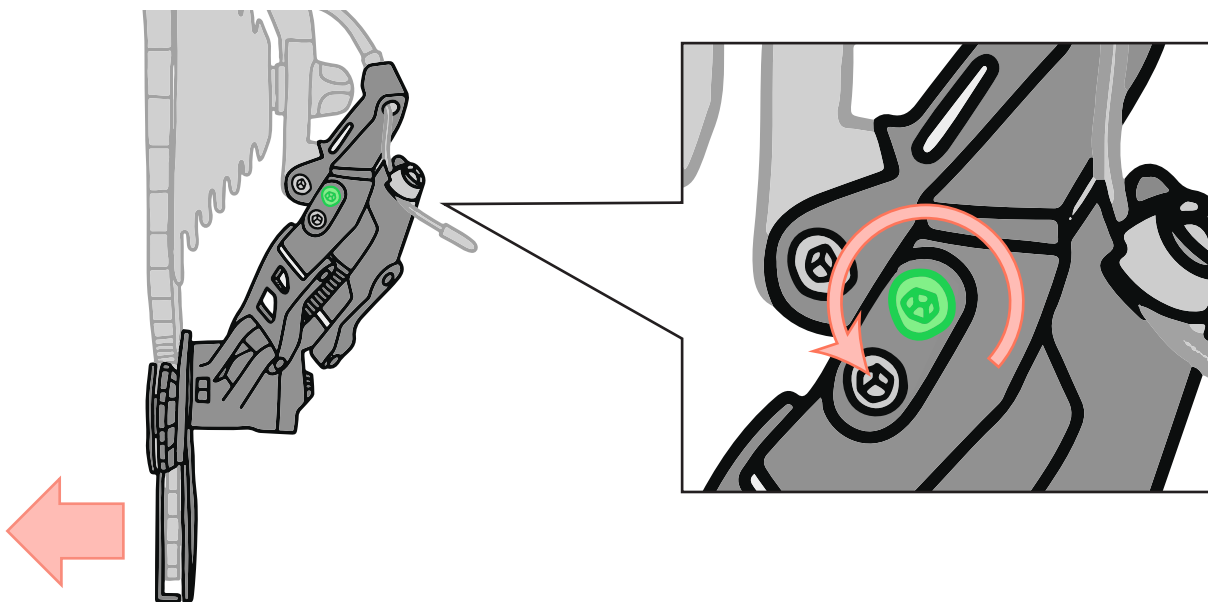
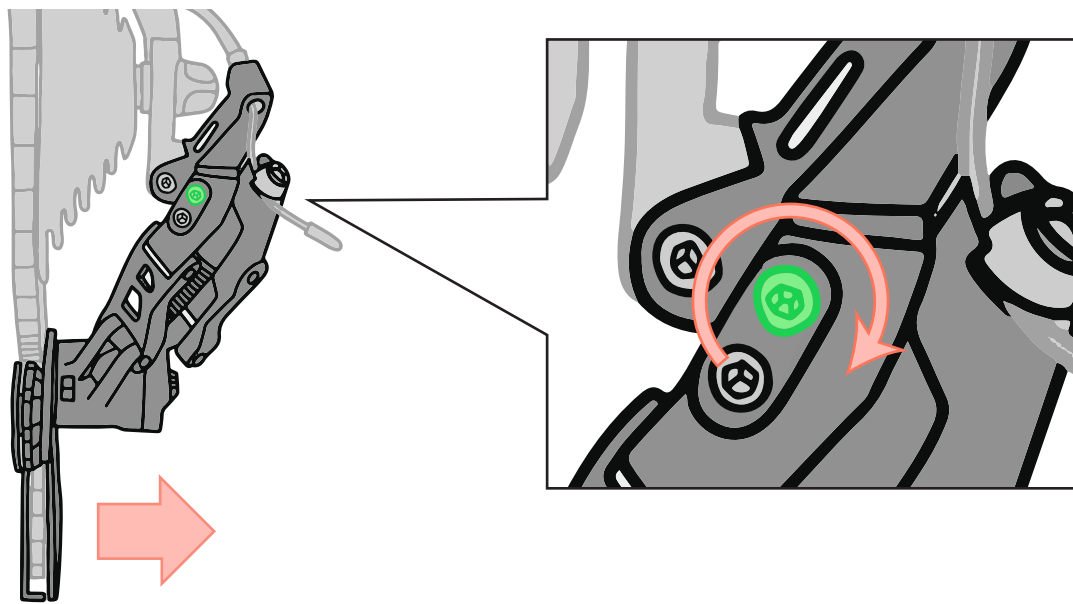



Adjust B-tension WITH a derailleur adjustment tool

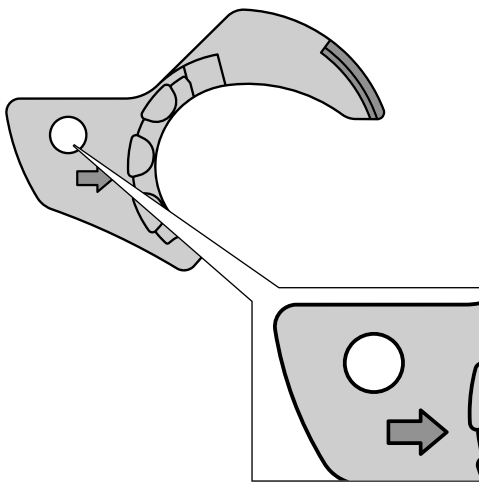

For 53mm,93mm use Version 1 tool

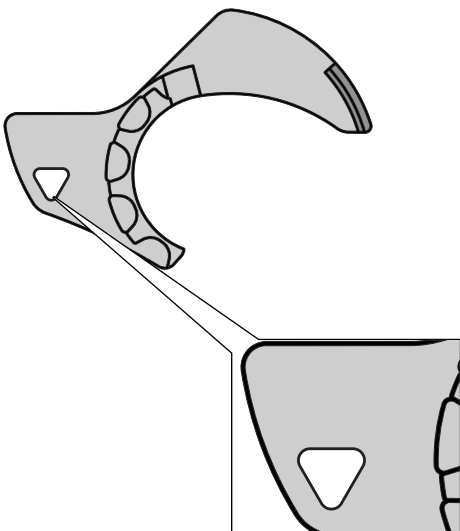

For 75mm use Version 2 tool

10. B-Tension Screw Adjustment

Part I



Adjust B-tension WITH a derailleur adjustment tool

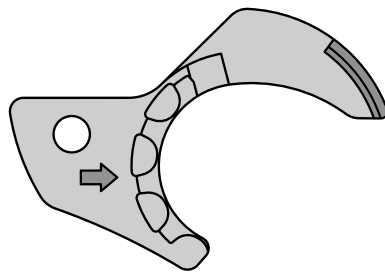

With the chain in the largest cog, tighten the **B-tension screw** to move the **guide pulley** away from the **the largest cog**.

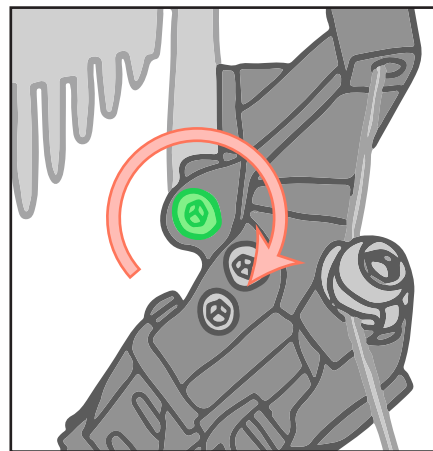
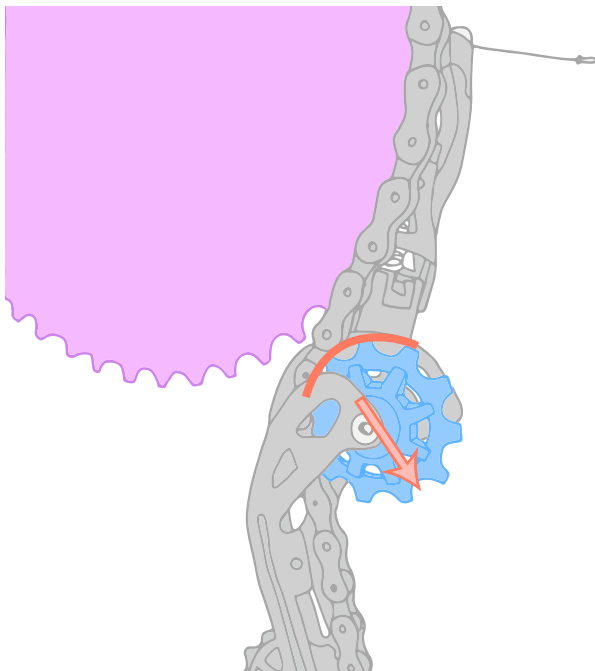

10. B-Tension Screw Adjustment

With the chain in the largest cog, tighten the **B-tension screw** to move the **guide pulley** away from the **the largest cog**.

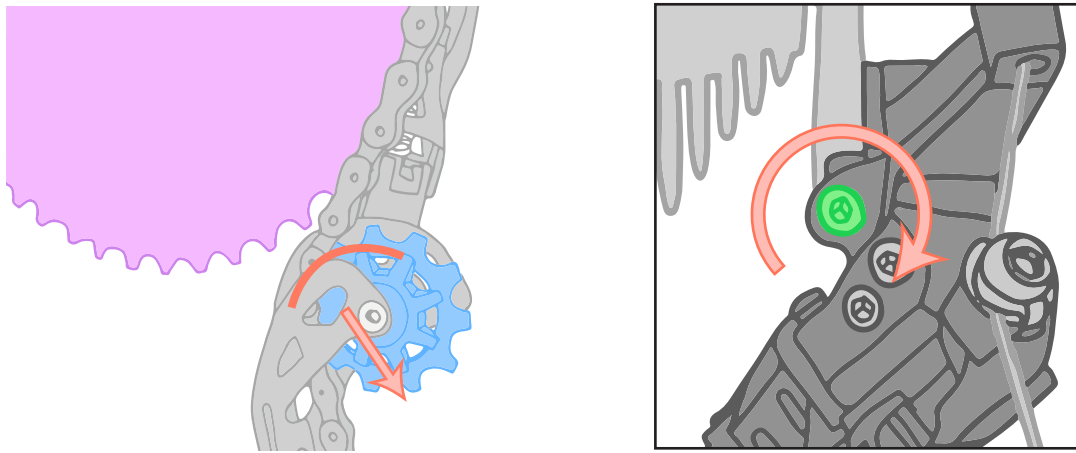

Snap **the derailleur adjustment tool** on to the **guide pulley**. Make sure **the tool** is touching the **chain** but not touching the **cassette cog**. Tighten the B-tension screw if the tool does not have enough room.

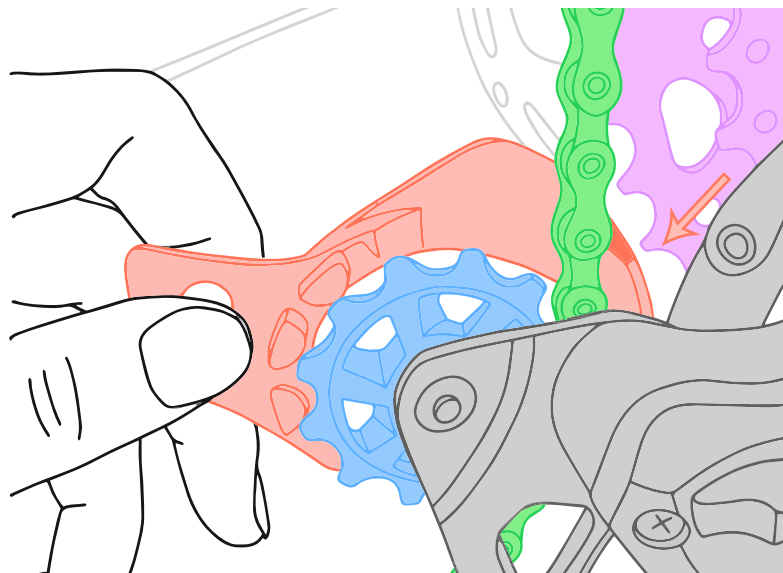

10. B-Tension Screw Adjustment

Part II

Loosen the **B-tension screw** until **the derailleur adjustment tool** lightly touches **the tallest tooth of the largest cog**. Remove the tool when finished.

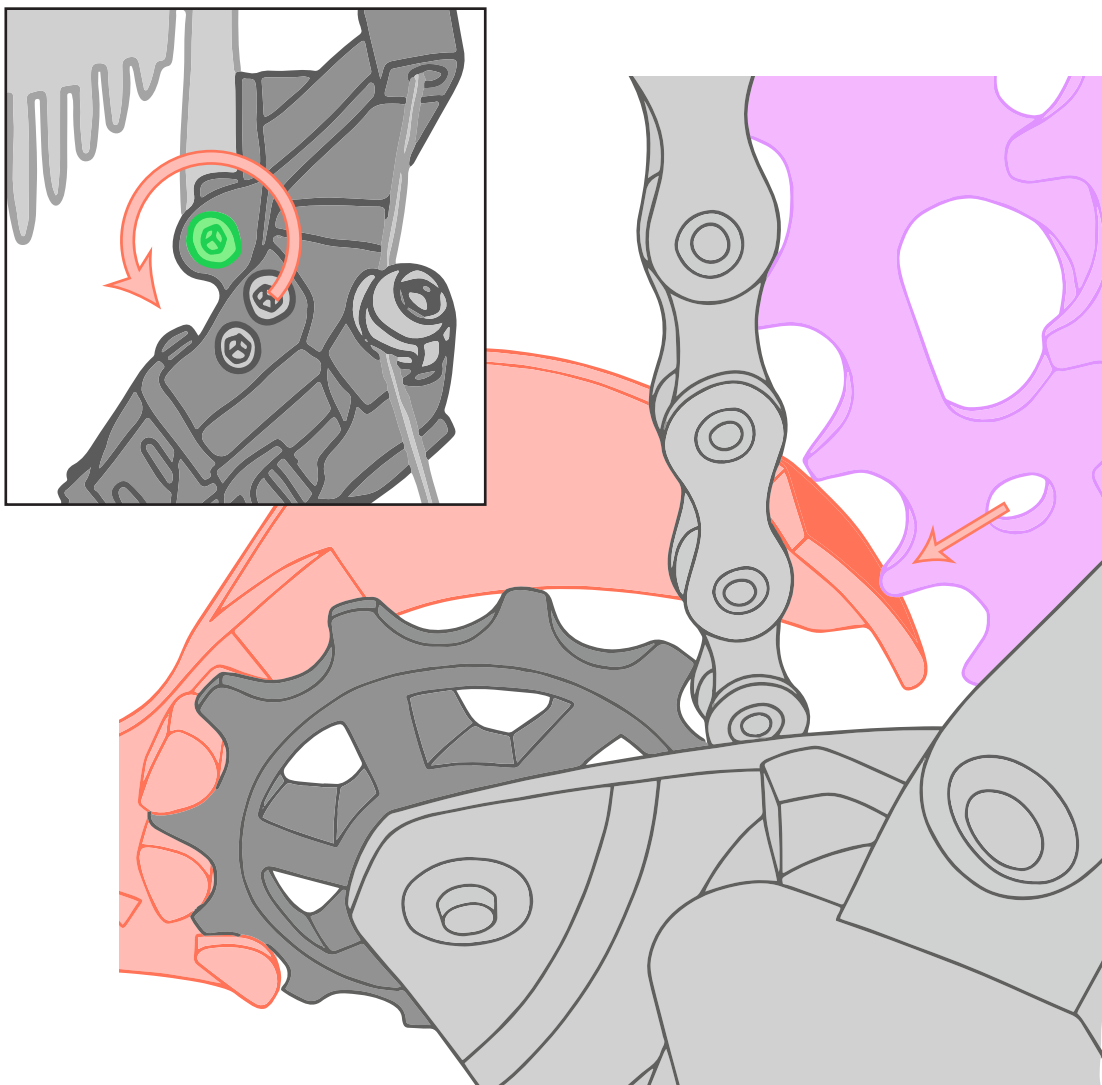

10. B-Tension Screw Adjustment

 **Adjust B-tension WITHOUT a derailleur adjustment tool**

Adjust the **B-tension** screw to set the distance between the **guide pulley** and **the tallest teeth of the largest cog**.

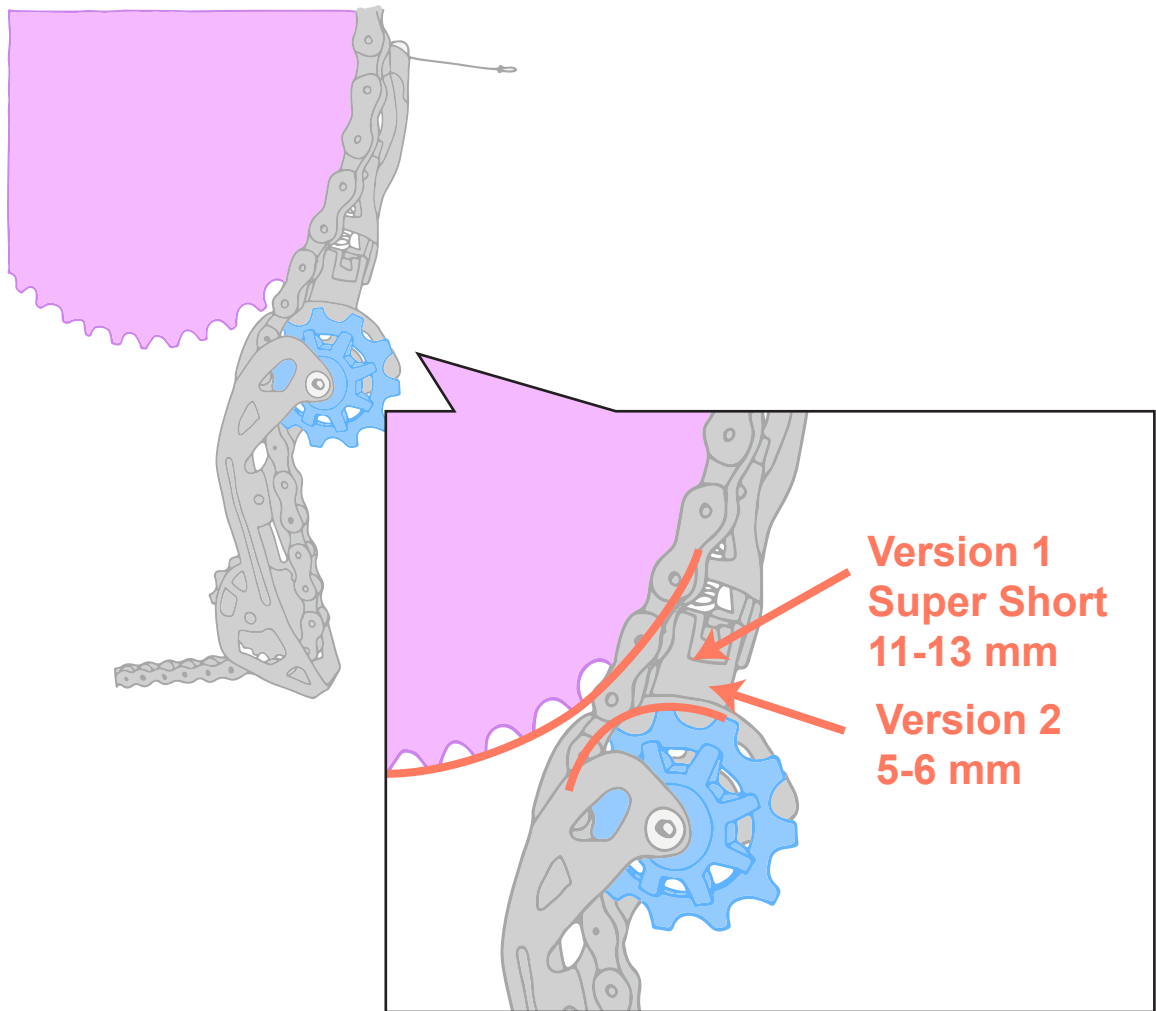

microSHIFT



www.microSHIFT.com