

# microSHIFT

## Road 2x Front Derailleur Installation

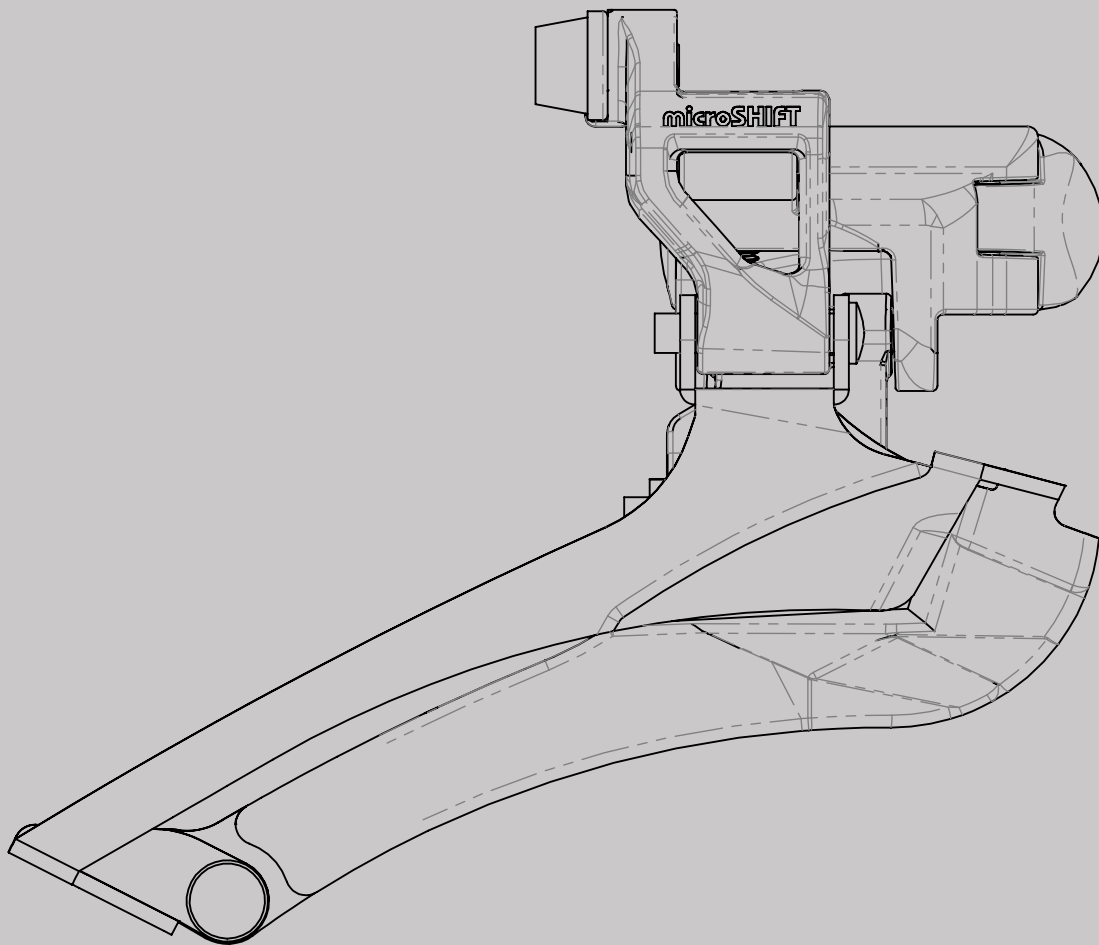

# Important Notice



## REMINDER

Before installing the products, please read and understand the installation procedures. Improper installation can lead to premature product failures or even injuries. If you have any questions on how to install, please contact us or consult with a professional bicycle mechanic.

# Tools and Supplies

1. Torque wrench
2. 4mm hex bit
3. 5mm hex bit
4. 4mm hex wrench
5. 5mm hex wrench
6. Cable cutter
7. Philips screwdriver

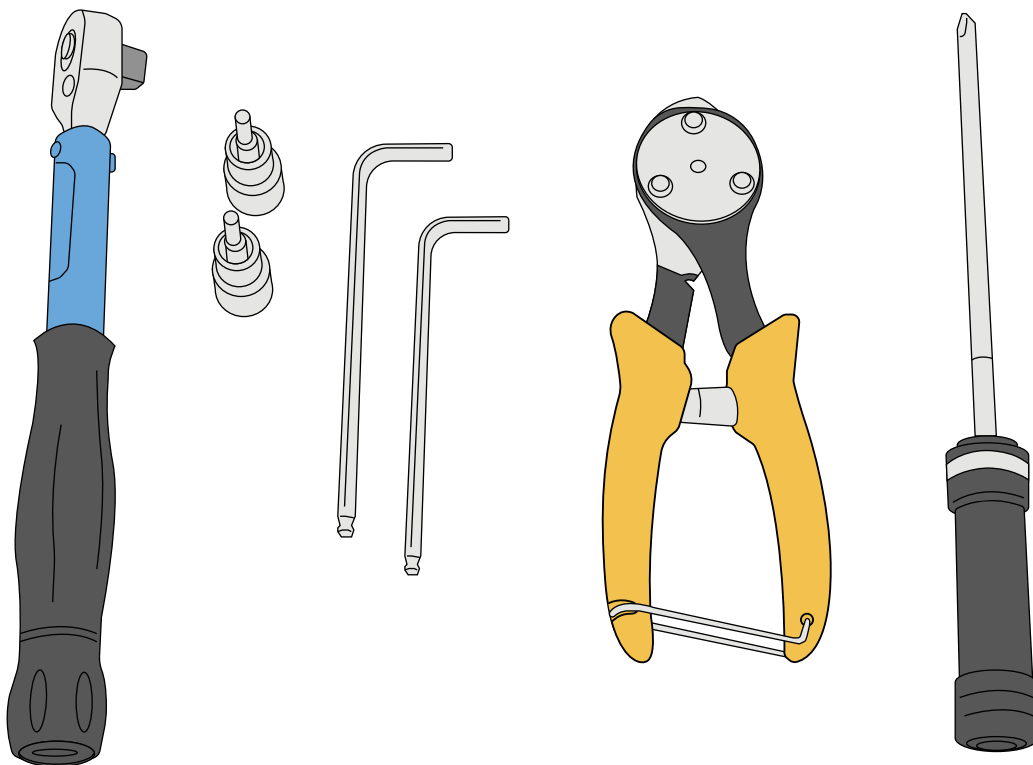

# 1.

## Attach the Derailleur to the Frame

Use a **5mm hex wrench** and loosely attach the derailleur to the seat tube using the braze-on attachment or band clamp.

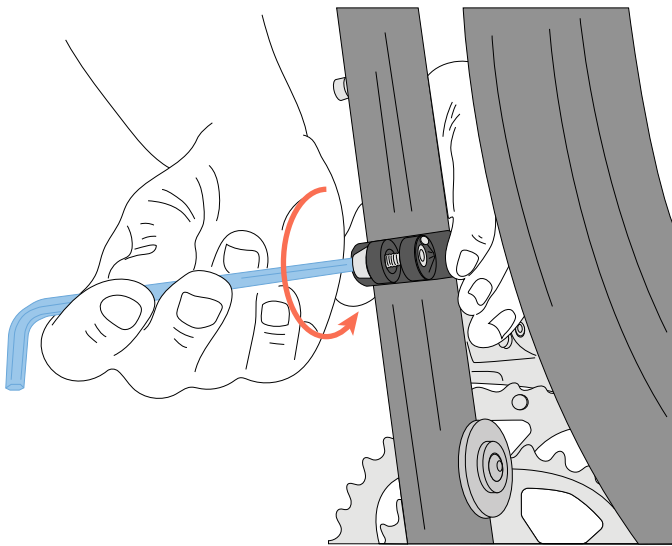

----- **Band Clamp**

**Braze On** -----

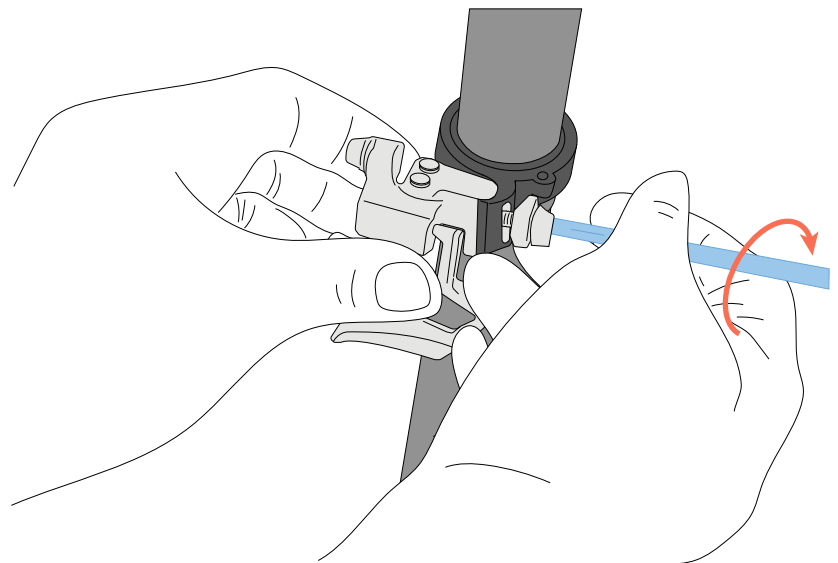

# 2.

## Attach the Derailleur to the Frame

Position the derailleur so that the **outer plate** of the chain guide is **parallel** to **the largest chainring**.

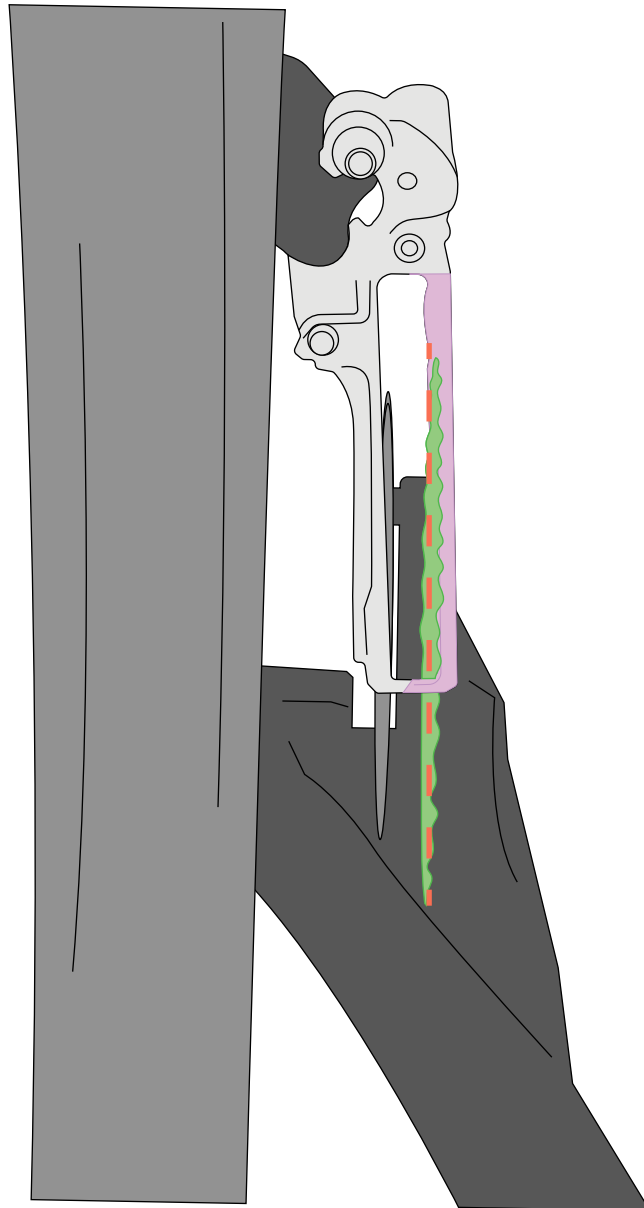

# 3.

## Attach the Derailleur to the Frame

Position the derailleur so there is **1-3mm** of distance between the derailleur's **outer plate** and the largest chainring.

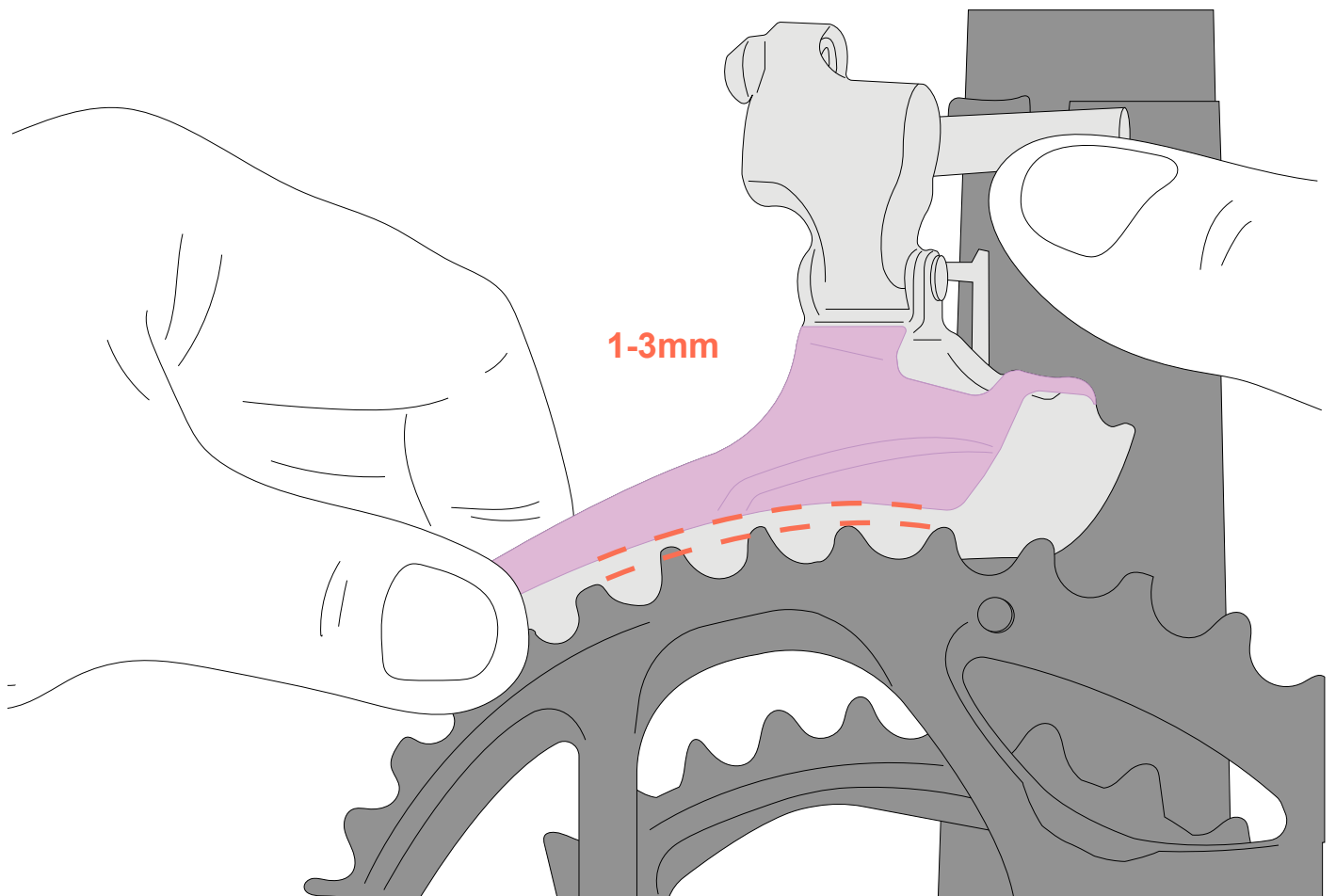

# 4.

## Attach the Derailleur to the Frame

Tighten the **mounting bolt** with **5mm Hex bit** to **5-7Nm**.

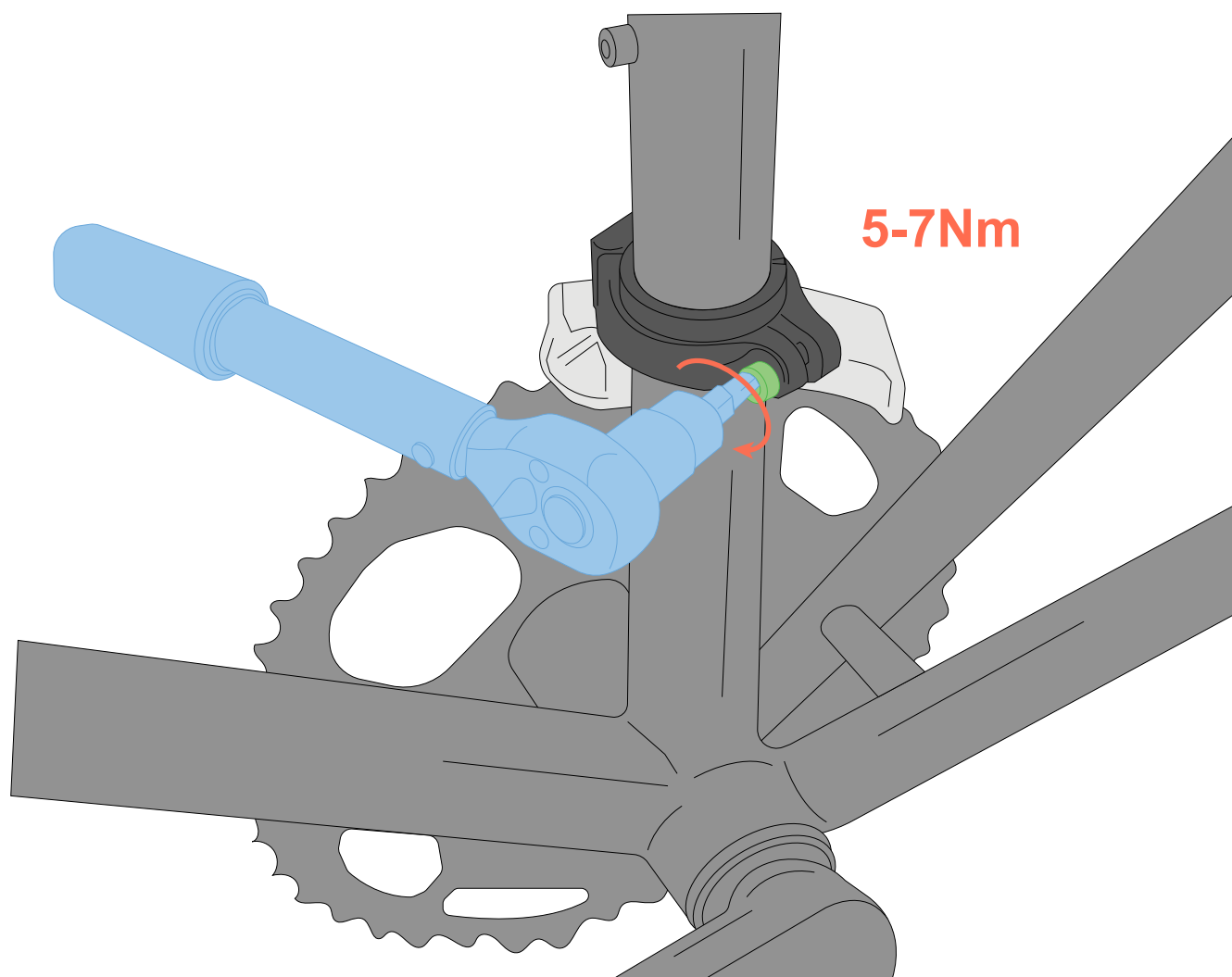

# 1.

## Low Limit Setup

Route **the chain** through the rear derailleur and around the small chainring. For proper chain measurement check out your rear derailleur installation manual.

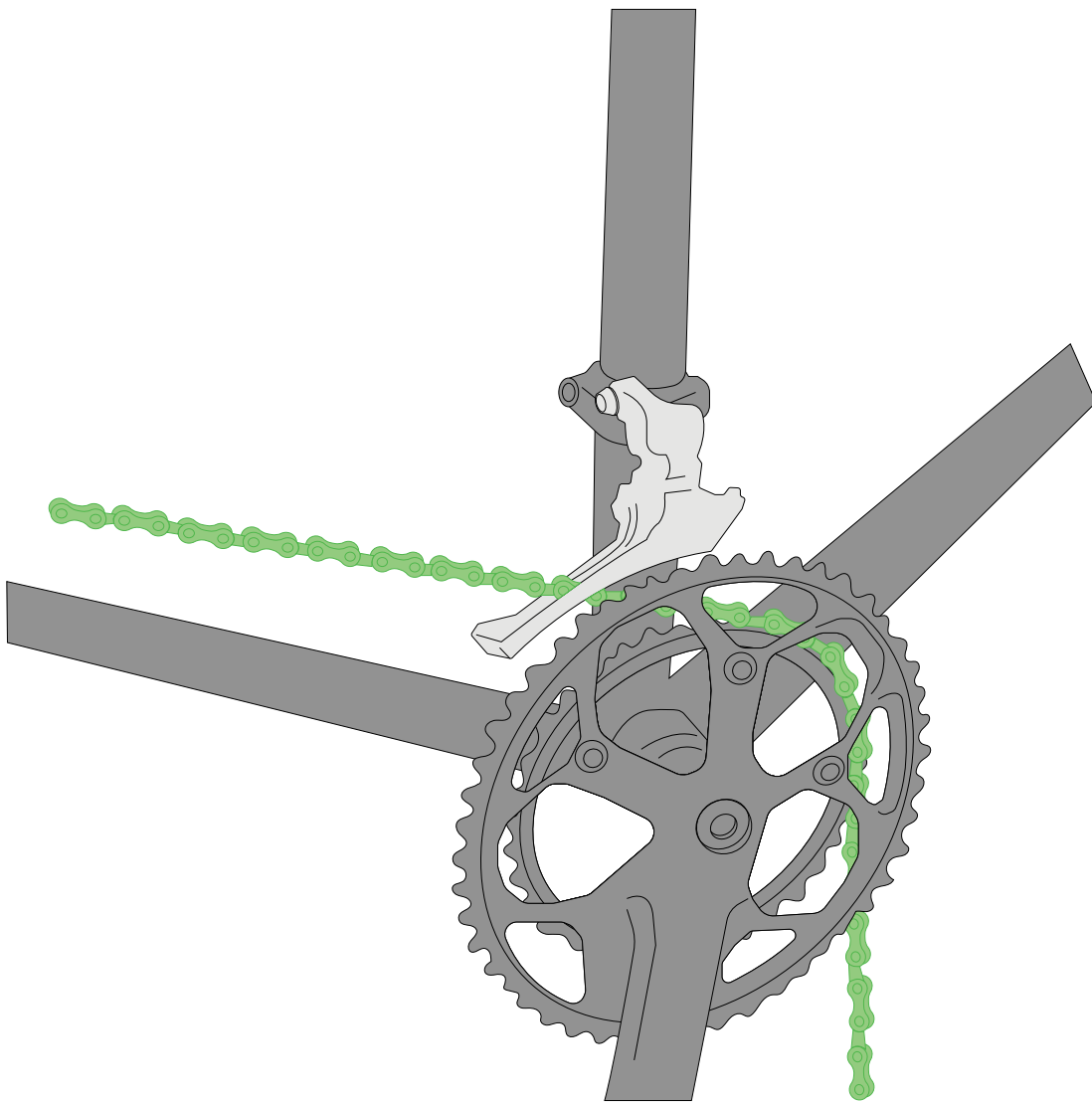



# 2.

## Low Limit Setup

With **the chain** on the small chainring, shift **the chain** to the **largest cassette cog**. This puts the chain at its most inboard position.

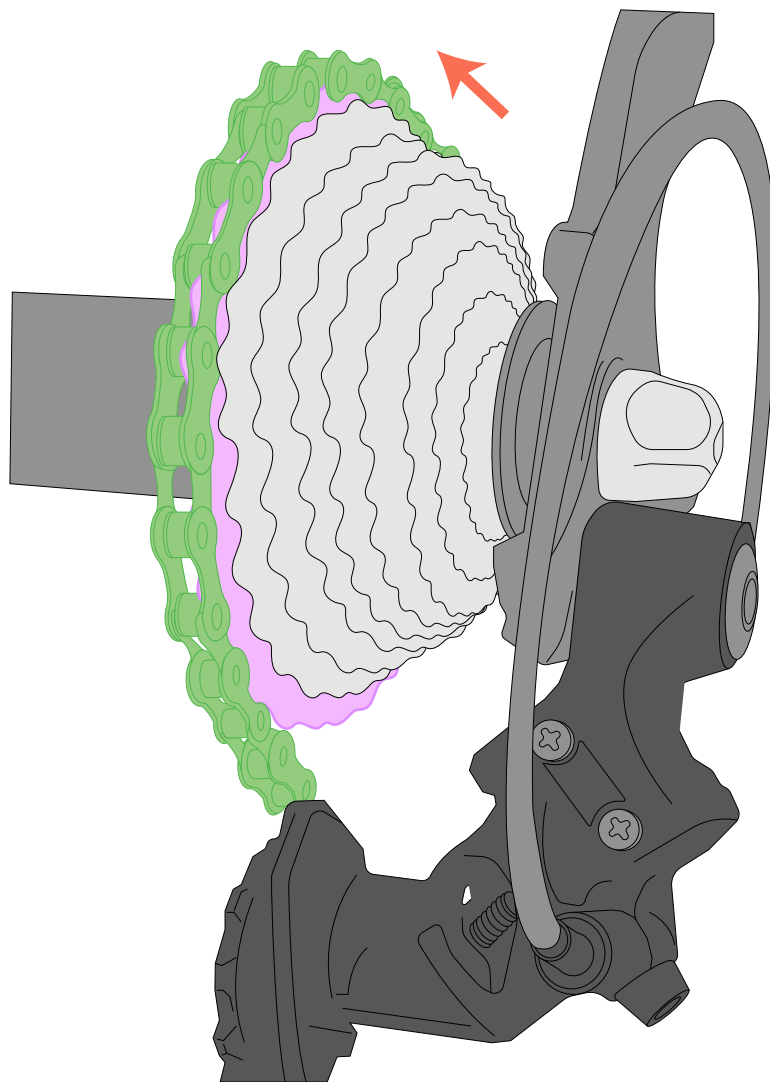

# 3.

## Low Limit Setup

Use the **Philips head screwdriver** and turn **the low limit screw** until the space between **the chain** and the front derailleur's inner plate is about **0.1-0.5 millimeters**.

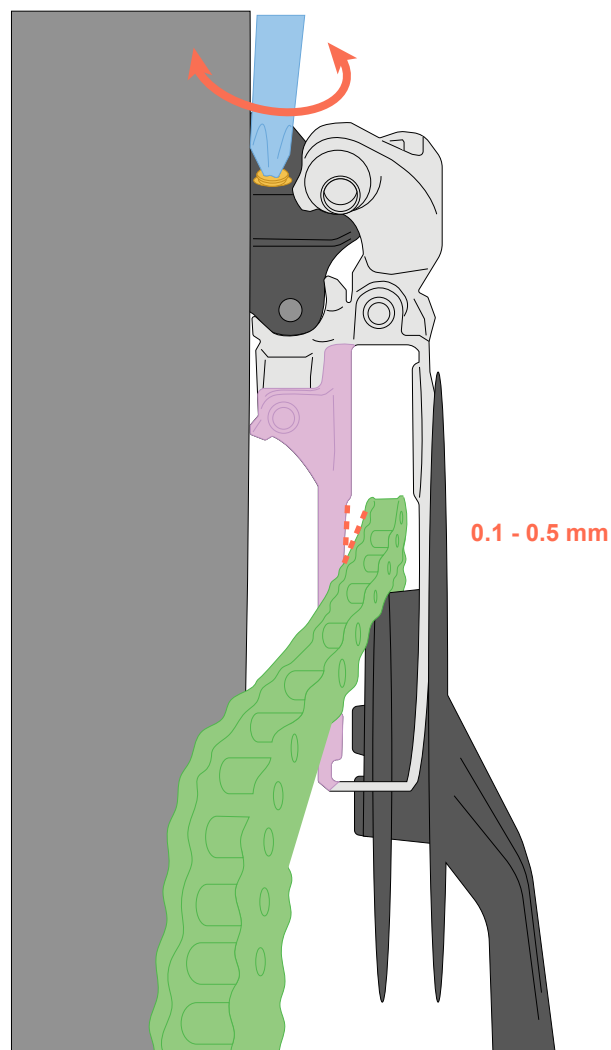

# 4.

Turning the **screw** clockwise moves the cage toward the outer chainring, and turning it counterclockwise allows it to move toward the inner chainring.

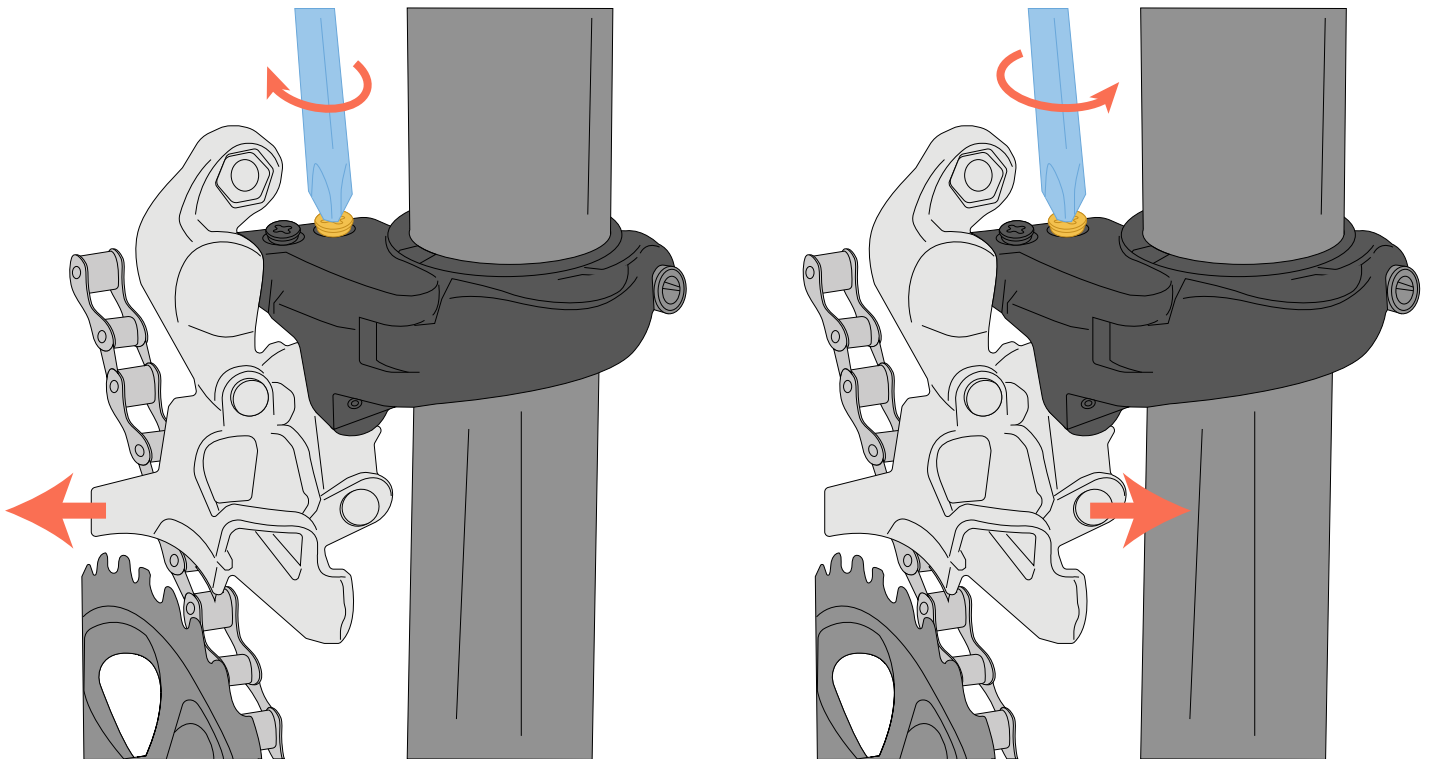

# 1.

Route your **shift cable** and housing. Every frame manufacturer has a different cable routing guideline, so make sure you consult those first before sizing and cutting your housing. Route the **shift cable** through the housing, over the **tab** and through the **grove** below the **cable fixing bolt and washer**.

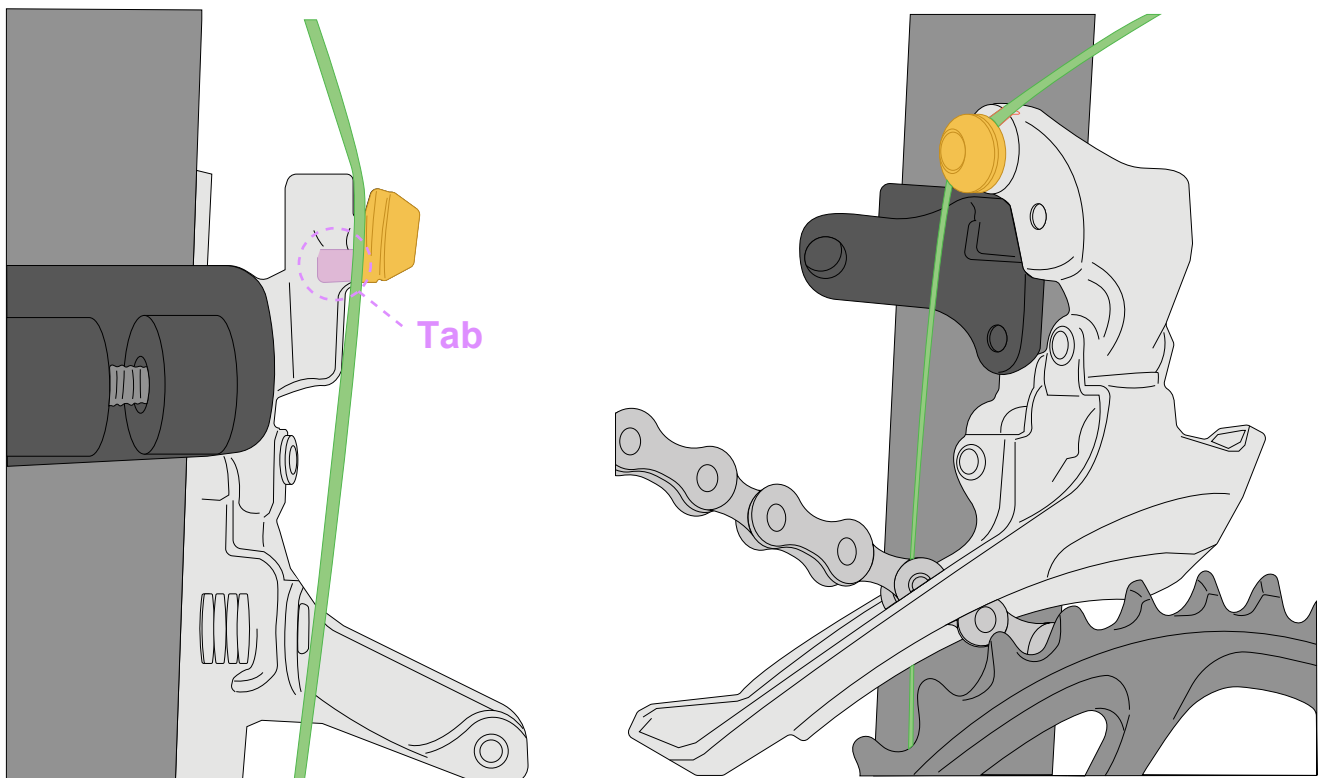

# 2.

Pull the  **cable**  tight to remove any slack and secure the cable fixing bolt to  **5 - 7nm** .

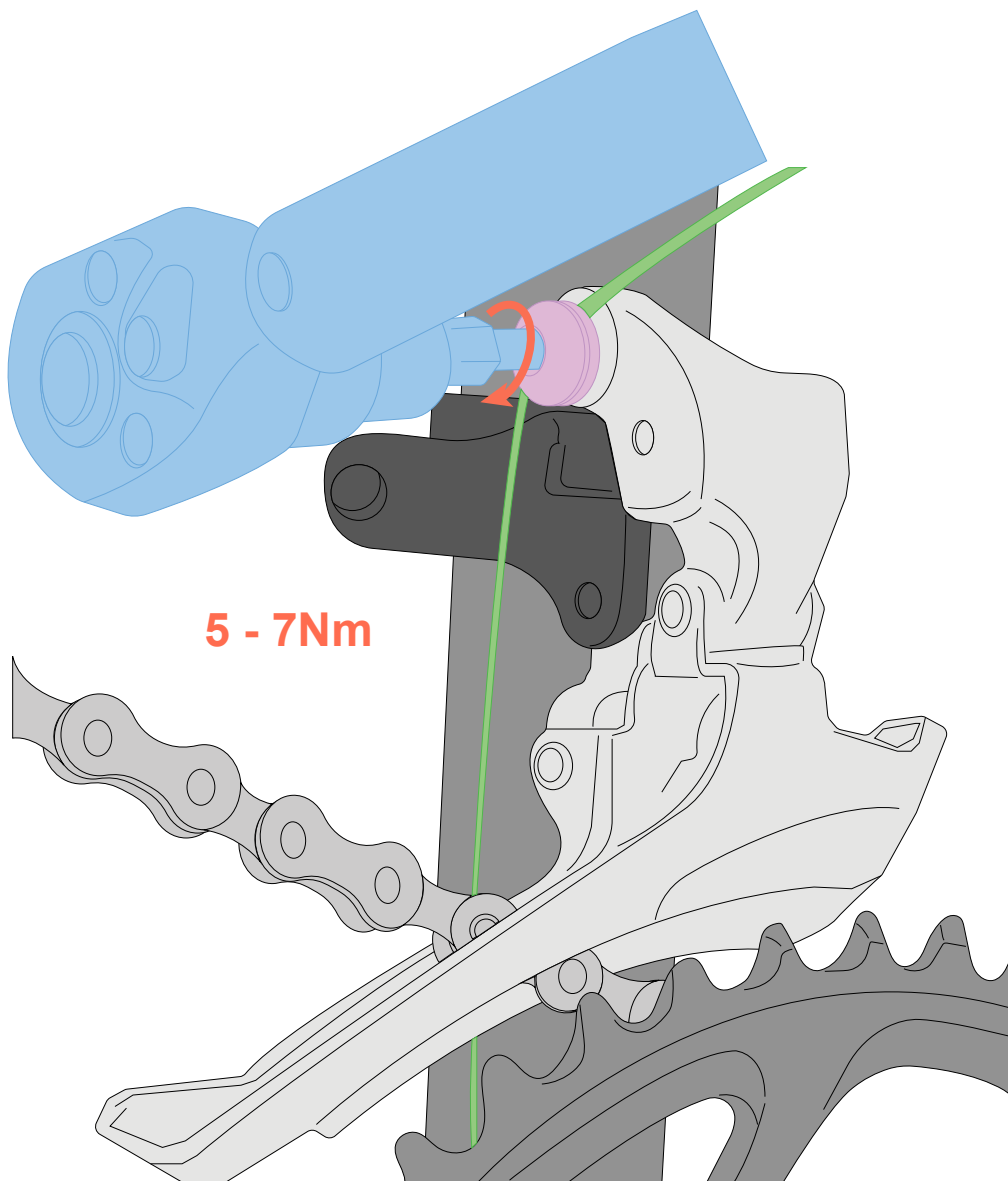

# 3.

Trim the cable and add a  **cable end**.

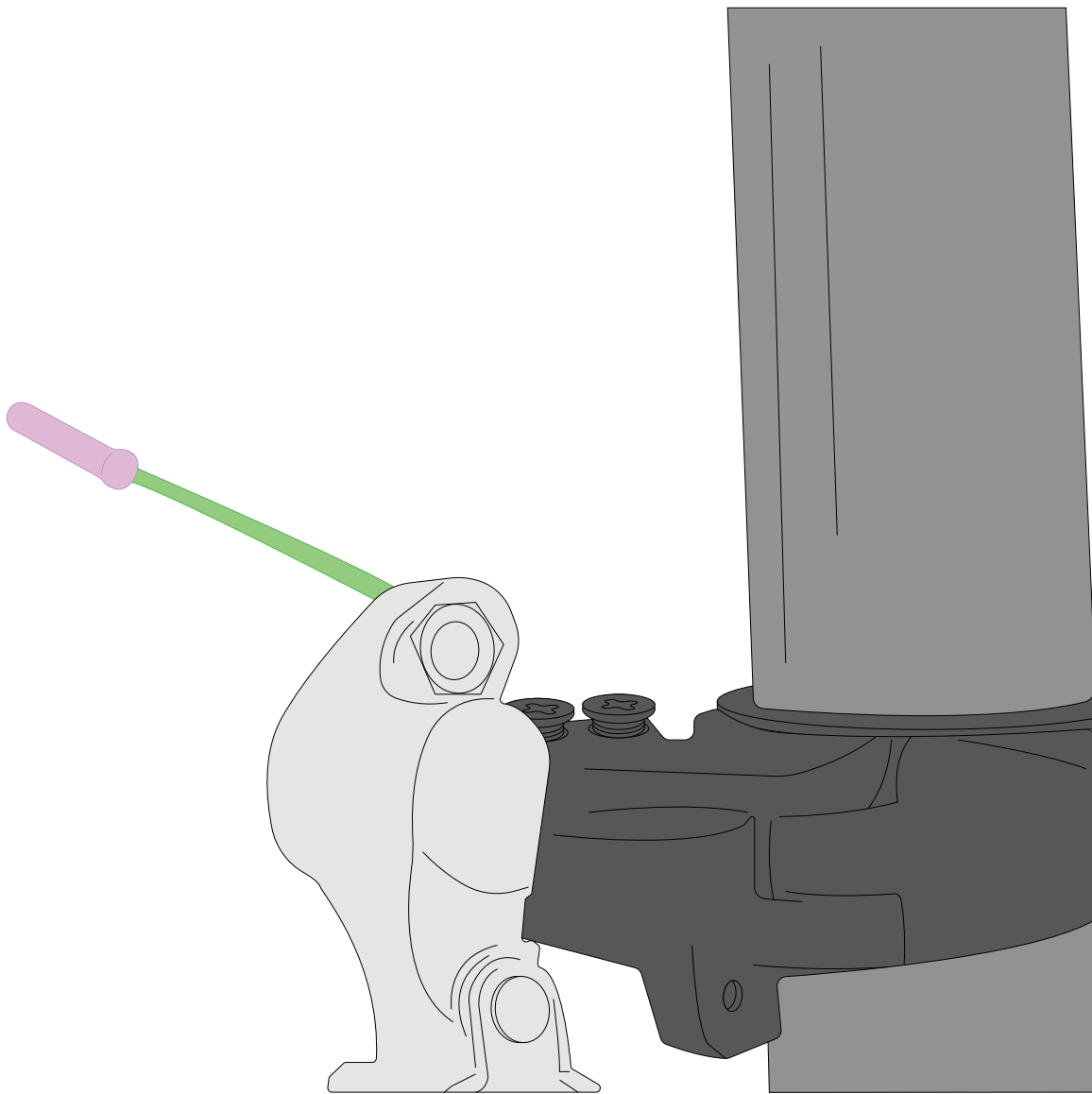

# 1.

## Cable Adjustment

Shift between chainrings. If the **chain** struggles to shift from the largest to smallest chainring, your cable is too tight. If available, turn the **barrel adjuster** on your frame or shifter clockwise. Make incremental adjustments. Test the derailleur for function after each adjustment.

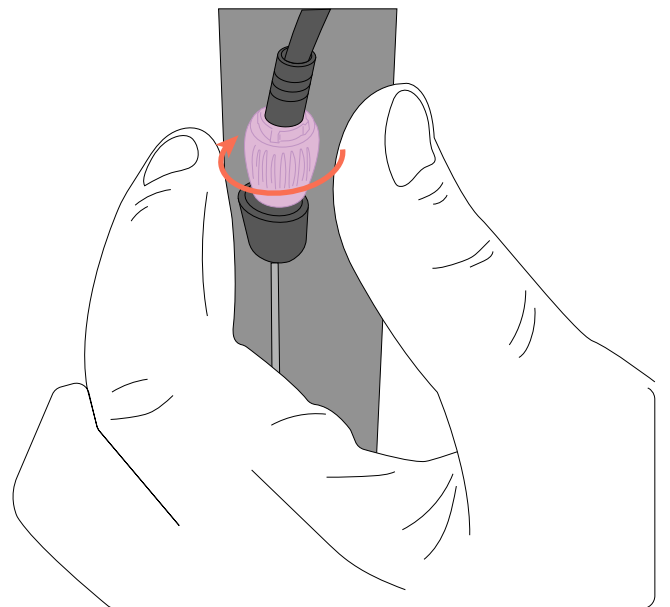
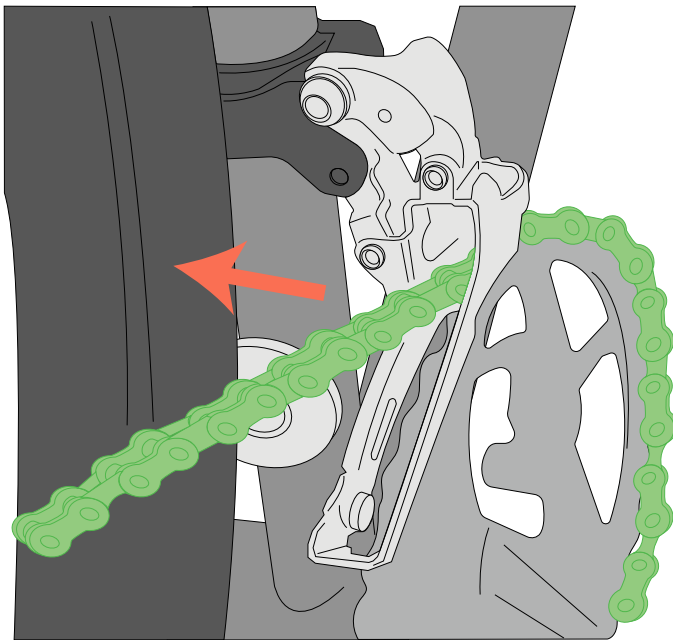

# 2.

Shift between chainrings. If the **chain** struggles to shift from the smallest to largest chainring, your cable is too loose. If available, turn the **barrel adjuster** on your frame or shifter counterclockwise to increase cable tension. Make incremental adjustments. Test the derailleur for function after each adjustment.

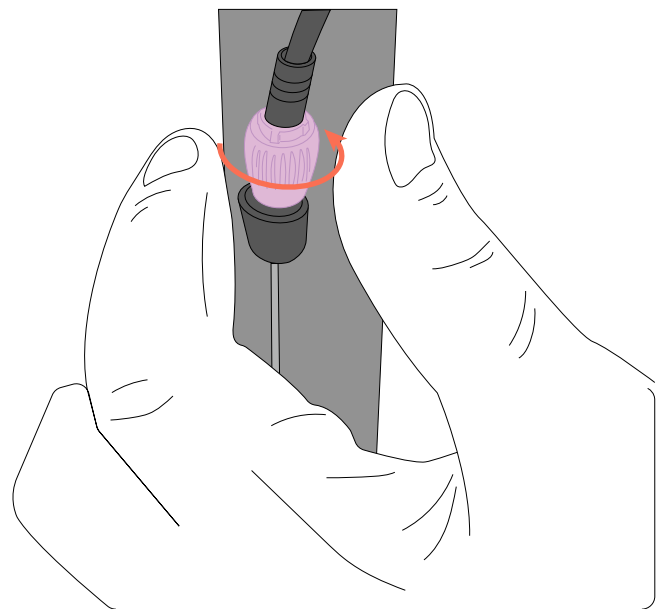
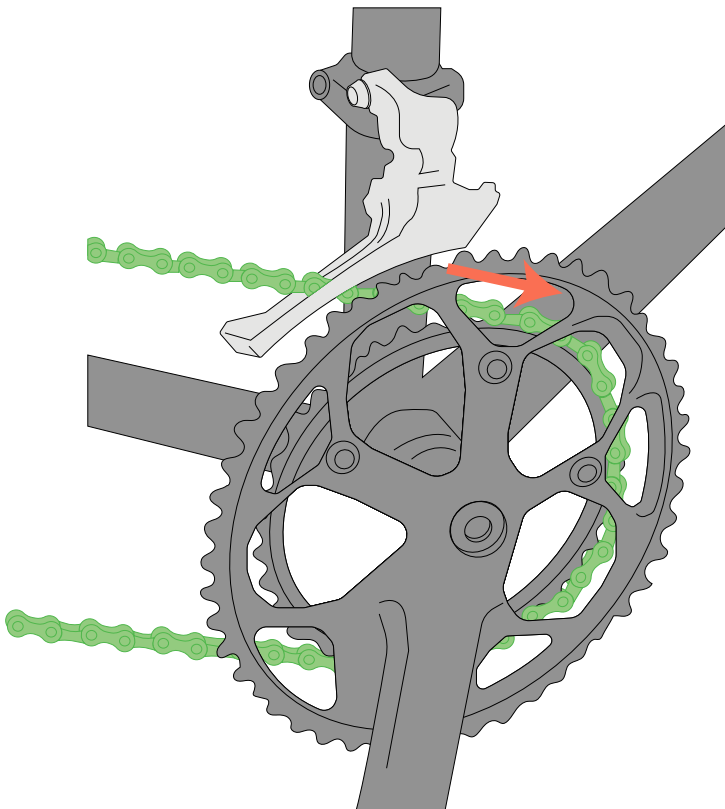



# 3.

If no barrel adjuster is available you can make the **cable** tension adjustment at the pinch bolt. Loosen the pinch bolt and pull or loosen the cable. Pulling the cable tight will help shifts the large ring. Making the cable lose will help shifts to the small ring.

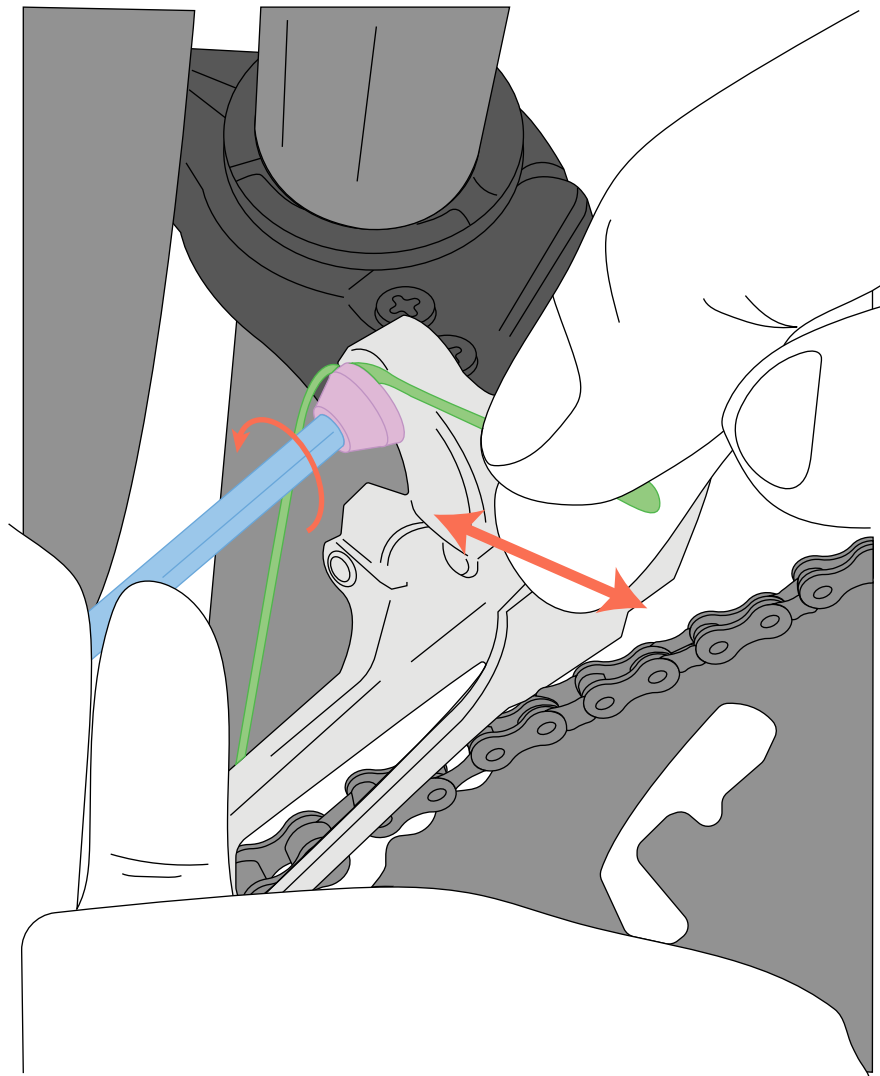

# 1.

## High Limit Adjustment

With the chain on the large chainring, shift the **chain** to the smallest cassette cog. This puts the chain at its most outboard possible position.

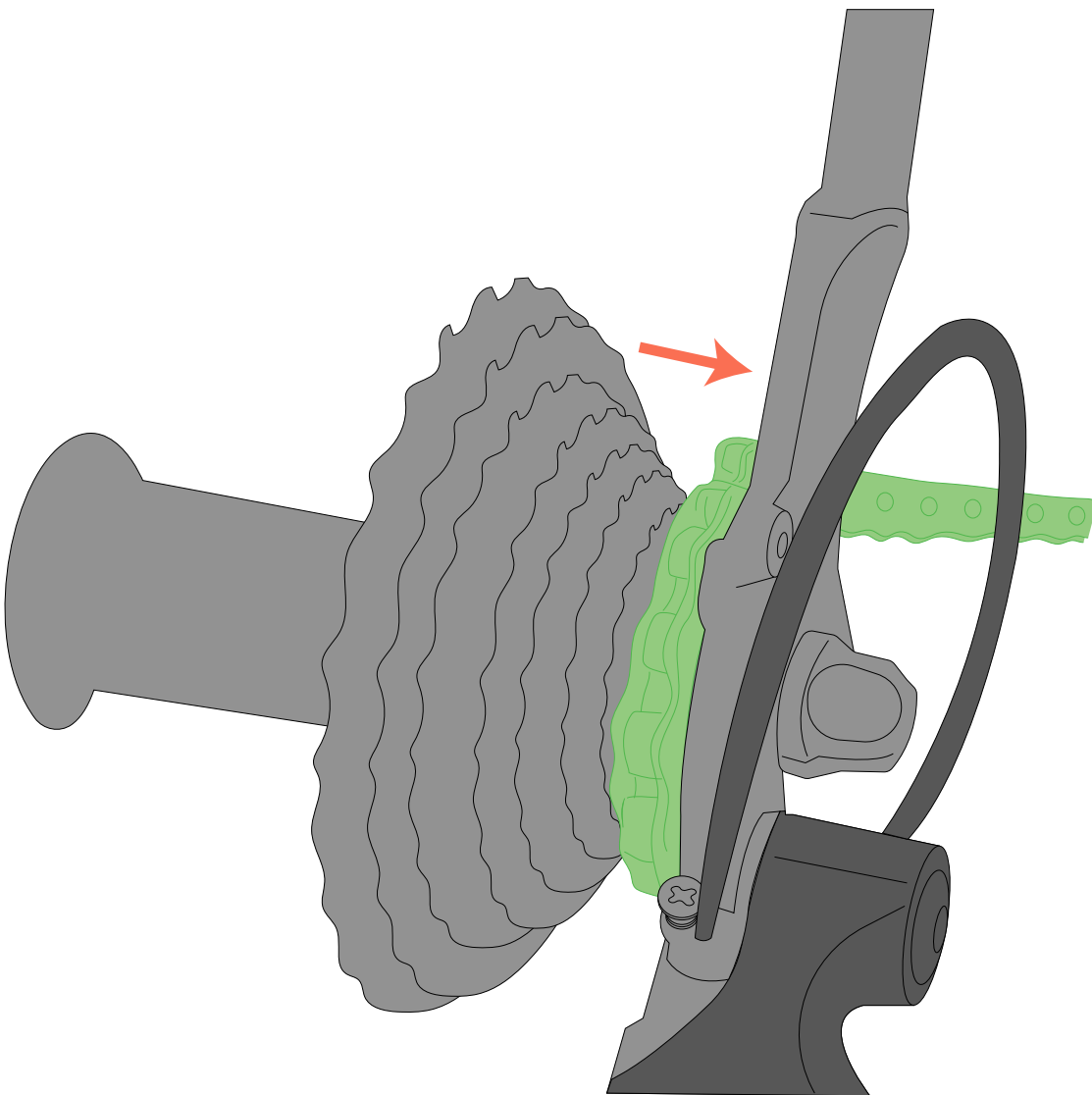

# 2.

## High Limit Adjustment

Turn the **high limit screw** until the gap between the chain and the **outer place of the derailleur** is about **0.1-.5mm**.

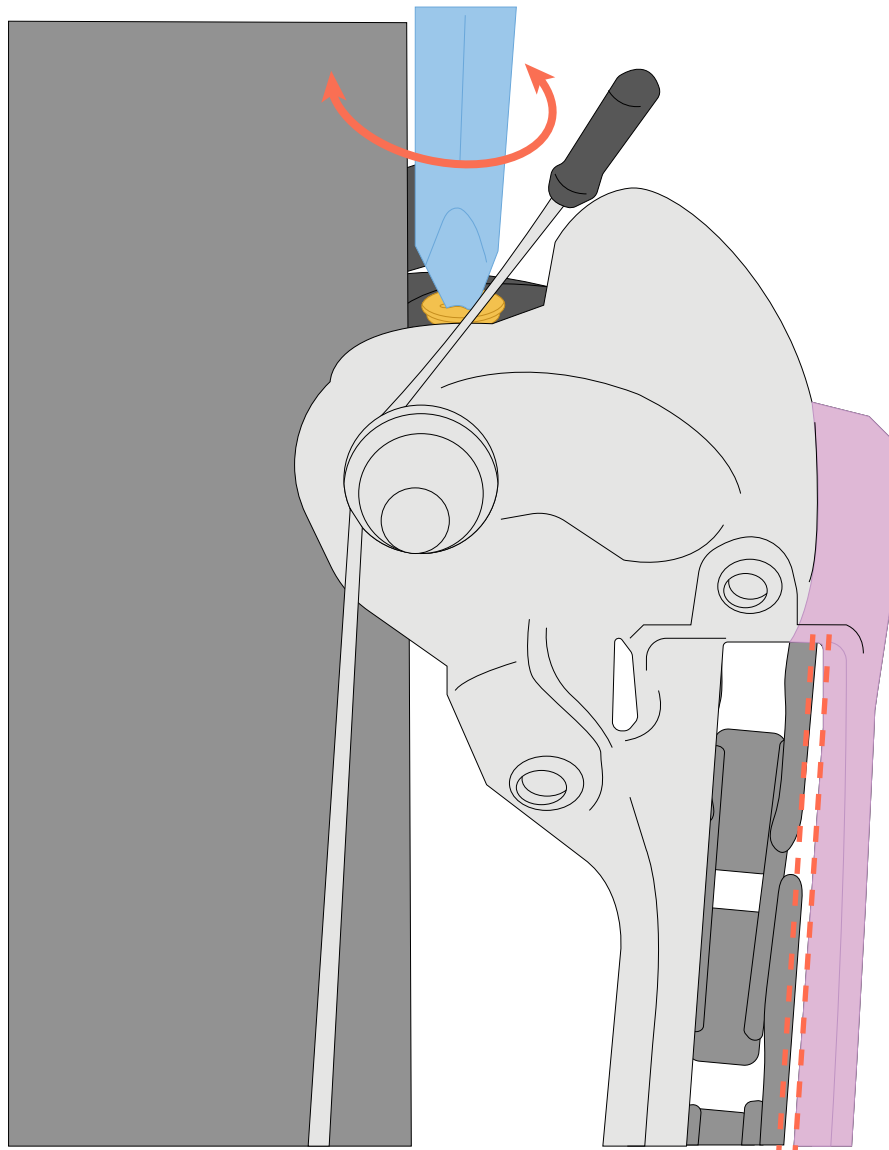

# 3.

## High Limit Adjustment

Turning the **screw** clockwise moves the **cage** towards the inner chainring.  
Turning the **screw** counter clockwise allows the **cage** to move towards the outer chainring.

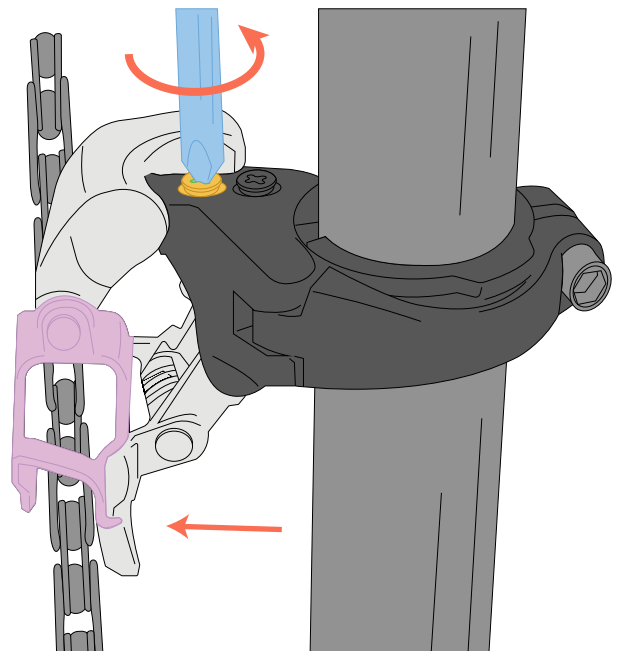
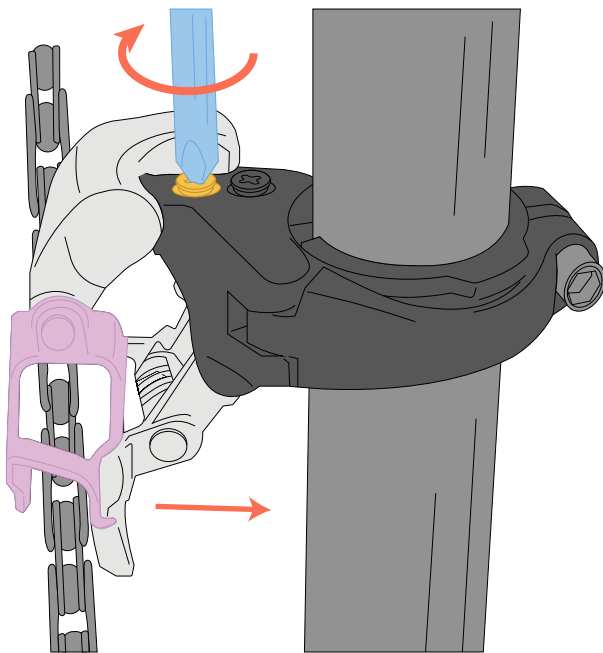

# microSHIFT



[www.microSHIFT.com](http://www.microSHIFT.com)