



HONDA

05-11 TRX500 Foreman and Rubicon

2012-13 TRX500 Rubicon

98-04 TRX450, 95-07 TRX400 Rancher,

00-06 TRX350 Rancher 2x4 & 4x4

ITEM	PART#	QTY.	DESCRIPTION
1	2723-70	1	Plow Mount Weldment
2	HDW2063	4	5/16 x 1-1/4 x 2-1/4 Rd. U-Bolt
3	HDW2158	2	5/16 x 1-3/8 x 2 Rd. U-Bolt
4	HDW9002	8	5/16 Flat Washer
5	HDW7058	8	5/16 Nylock Nut

PART# 4501-0596

Remove the plastic skid plate under the machine.

Attach the rear of the mount to the frame cross tube using two of the #2 U-bolts (5/16" x 1-1/4" x 2-1/4" U-bolts), washers and nuts as shown.

Swing mount forward and mount front portion to the outside frame tubes as shown (there is additional U-bolts for the machine with larger frame tubes). Use remaining washers and nuts to secure.

Align mount and tighten.

Push tube will pin up to tabs on the bottom with the wire loop pins supplied with push tube.

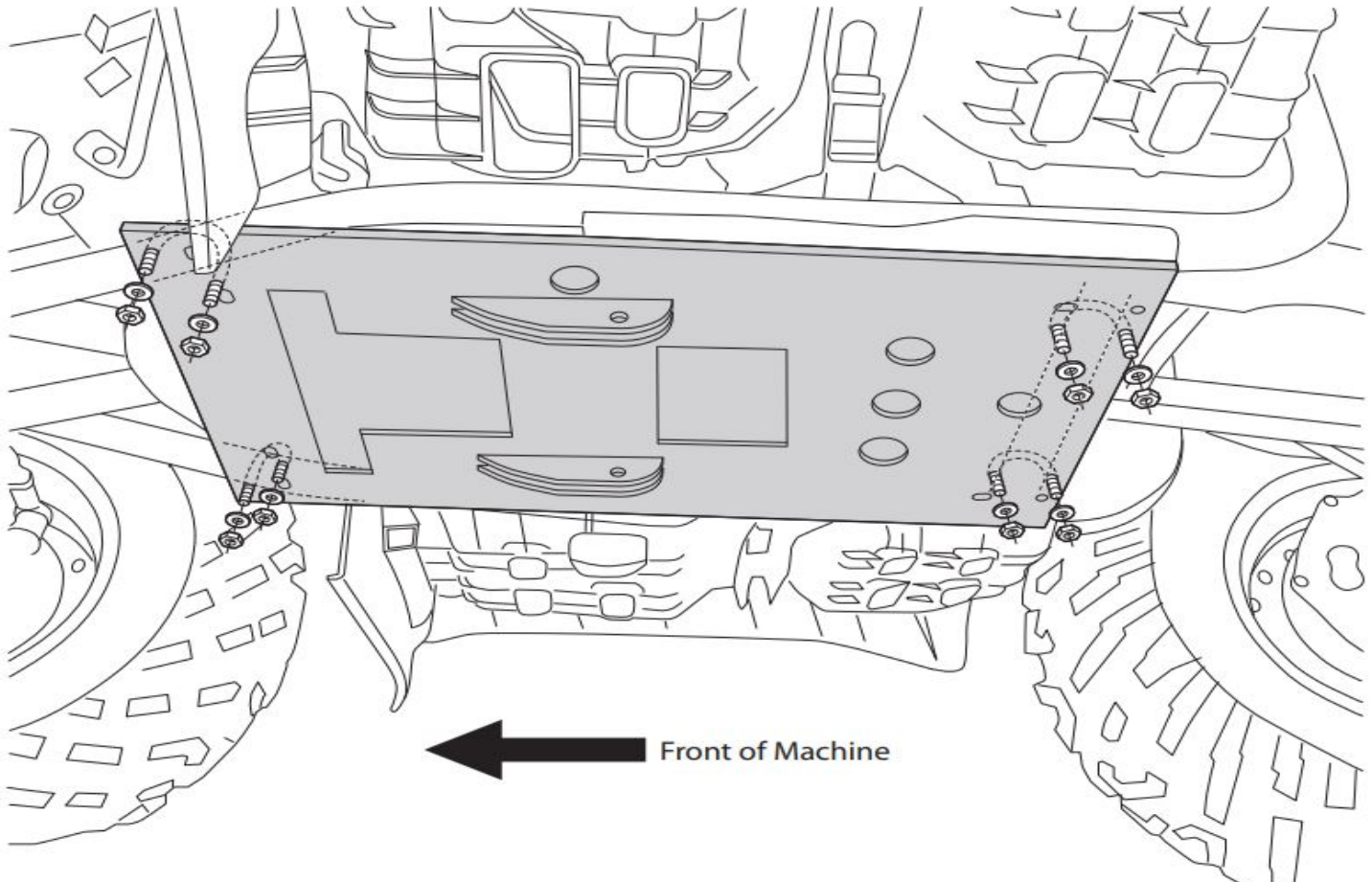

FOR QUESTIONS OR COMMENTS PLEASE CALL: 320-964-1616 (7:00 to 4:30 CST Monday through Thursday).

INST2723PF