

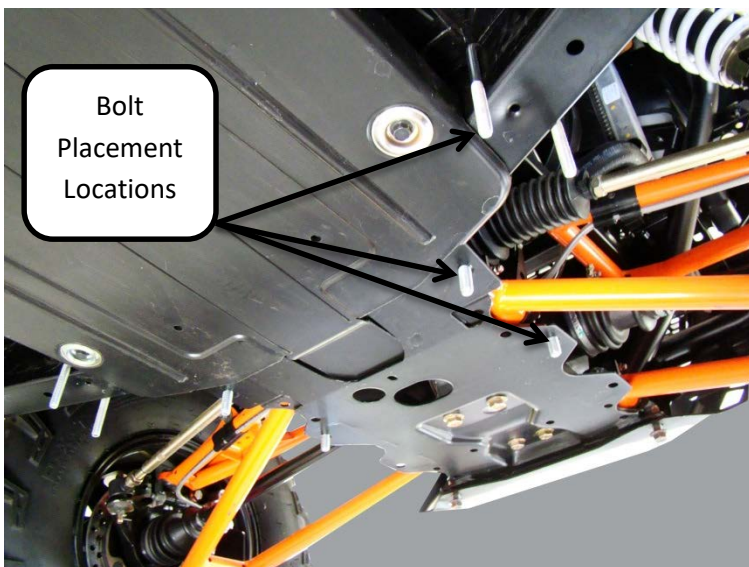

## BOTTOM MOUNT INSTALLATION INSTRUCTIONS 2016 POLARIS RANGER 570XP (full size)

- 1 – Locate the four open holes in the bottom of the chassis on either side of the front of the a-arms. Position the two 3/8 x 1 hex bolts into the holes just behind the a-arms so they are hanging down through the holes. Position the two 3/8 x 3/4 hex bolts into the front most holes with them also hanging down through the holes.
- 2 – You may install with skid plate removed but if you want it in place you will have to lightly attach bottom to the four bolts in place and mark where the u-bolts will come through using the bottom mount as a template and then remove bottom mount. Remove skid plate and attach u-bolts to frame as shown and then reattach skid plate.
- 3 – Locate the round spacers and place them on the bottom mount in their proper locations as shown on the drawing. Spacers go between bottom mount and machine.
- 4 – Carefully position the bottom mount up to the machine and over the hex bolts and u-bolts. Secure mount in place using the 5/16 washer and nylock nuts on the u-bolts and the 3/8 nylock nuts on the hex bolts. Tighten securely.

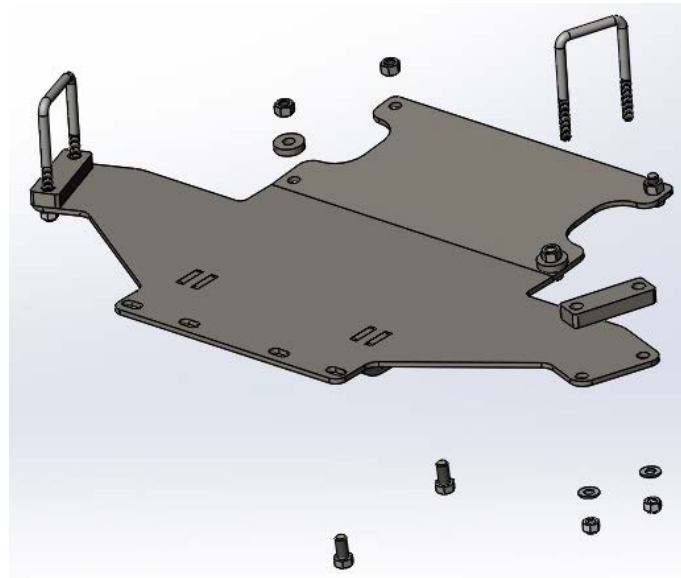





**BOTTOM MOUNT INSTALLATION INSTRUCTIONS**

2013-16 Polaris 900 Ranger / Crew

2015 Ranger 570-6 Full Size / 2016 Ranger 570 XP Full Size

PART# 4501-0656

QTY.	PART#	DESCRIPTION
1	2819-100	Bottom Mount
2	HDW9424	Spacer Block
2	HDW9427	1" rd x 1/4" LG Spacers
2	HDW2106	3/8 x 3/4 Hex Bolt
4	HDW7058	5/16 Nylock Nut
4	HDW9002	5/16 Flat Washer
2	HDW9062	5/16 X 2 x 3-1/2 U-Bolt
4	HDW7061	3/8 Nylock Nut
2	HDW2100	3/8 X 1 Hex Bolt

Bolt placement drawing for Ranger 900 and 570-

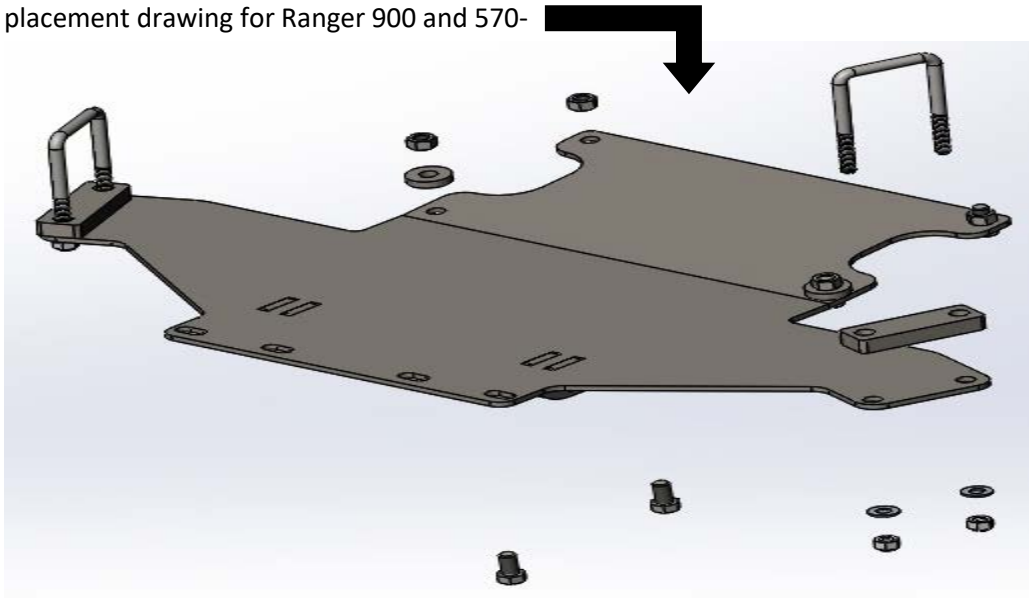

Bolt Placement drawing for Ranger 570 XP

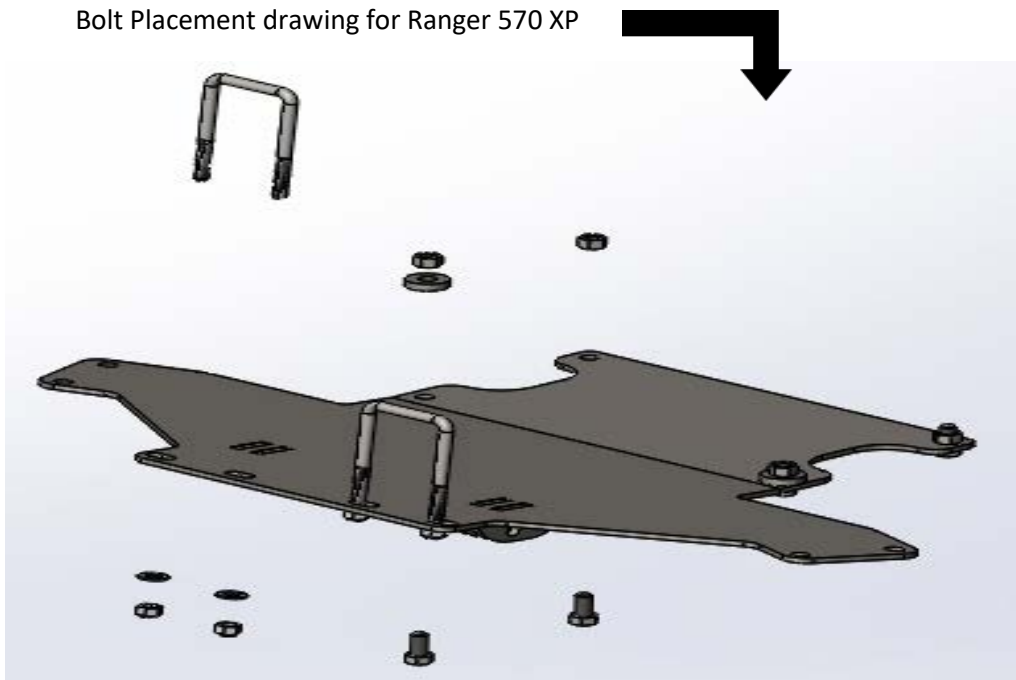



## BOTTOM MOUNT INSTALLATION INSTRUCTIONS 13-16 RANGER 900 / CREW RANGER 570-6 (full size)

- 1 - Locate the four open holes in the bottom of the chassis on either side of the front a-arms. Position the two 3/8 x 1 hex bolts into the holes just behind the a-arms so they are hanging down through the holes. Position the two 3/8 x 3/4 hex bolts into the front most holes hanging down through the holes.
- 2 - Hang u-bolts over the front cross member tubes just outside of the skid plate as illustrated. You may need to push up on the plastic to get u-bolts over the frame tubes. You should hold the plow mount up to bottom of machine and align with the first 4 bolts you put in to get the u-bolts in their proper location
- 3 - Locate the two spacer blocks and the round spacers and place them on the plow mount in their proper location as shown on the drawing. Spacers go between bottom mount and machine frame.
- 4 - Carefully position the plow mount up to the machine and over the hex bolts and u-bolts. Secure mount in place using the 5/16 washer and nylock nuts on the u-bolts and the 3/8 nylock nuts on the hex bolts. Tighten securely.

