

PARTS LIST

Qty.	Index	Description	Re-Order No.	Qty.
	1	Fairing Body		1
	2	Windshield	20-260010-000	1
	3	Upper Arm	34-344146-000	2
	4	Lower Rod	34-344145-000	2
Bag 136				
	5	Eyebolt, 3/8" Hole	52-521010-000	4
	6	Cup Spacer	49-496110-000	4
	7	Lock Washer	49-492310-000	4
	8	U-Clamp	37-420110-000	2
	9	Bevel Washer	49-493110-000	8
	10	Whizlok Nut, 3/8-16	42-432010-000	4
Bag 334				
	11	10-32 x 1/2" Screw	50-530410-000	8
	12	Whizlok Nut	42-439010-000	7
N6170 Mirror Assembly				
		Mirror, Left	60-600700-000	1
		Mirror, Right	60-600701-000	1
Bag 332				
		10-32 x 3/4" Screw	55-562211-000	4
		Acorn Nut	42-480201-000	4
		Flat Washer	49-490110-000	4

MAINTENANCE
MAINTENANCE

To clean the screen, wash with a clean soft cloth, plenty of warm water and , if necessary, a non-abrasive soap such as dishwashing liquid. Flannel or soft chamois make good cleaning cloths. Rinse well to remove all soap residue. Pat dry, do not wipe.

Remove paint, grease or glue residue with naphtha or turpentine, follow with wash as described above.

PRECAUTIONS

Never ride you ATV with loose fairing mounting hardware. Check the hardware for tightness regularly.

Have experienced service personnel correct any problems before riding with this fairing installed.

When transporting your vehicle remove windshield or face windshield in direction of travel.

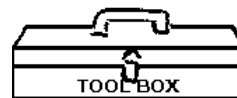

9/16" Wrench
Flat Head Screw Driver

INSTALLATION

NOTE: Right and Left side of ATV is determined while sitting on the vehicle.

Upper Rod

Figure 1.

Lower Rod

Figure 2.

1. Identify upper and lower rods. Figure 1 and 2.

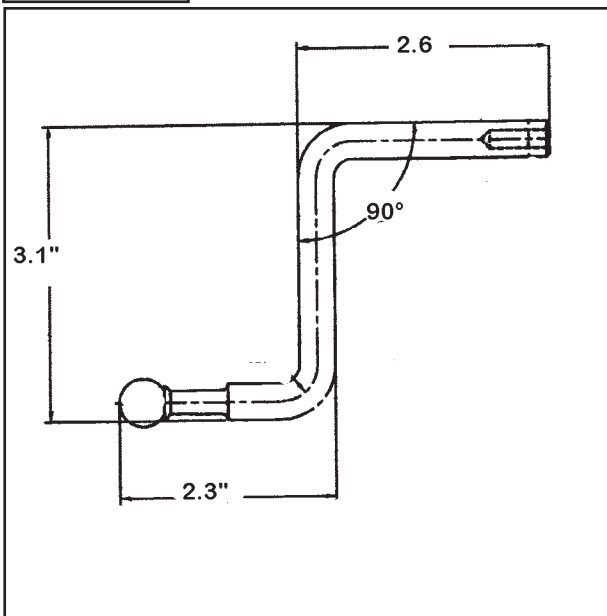
INSTALL UPPER AND LOWER RODS INTO FAIRING BODY

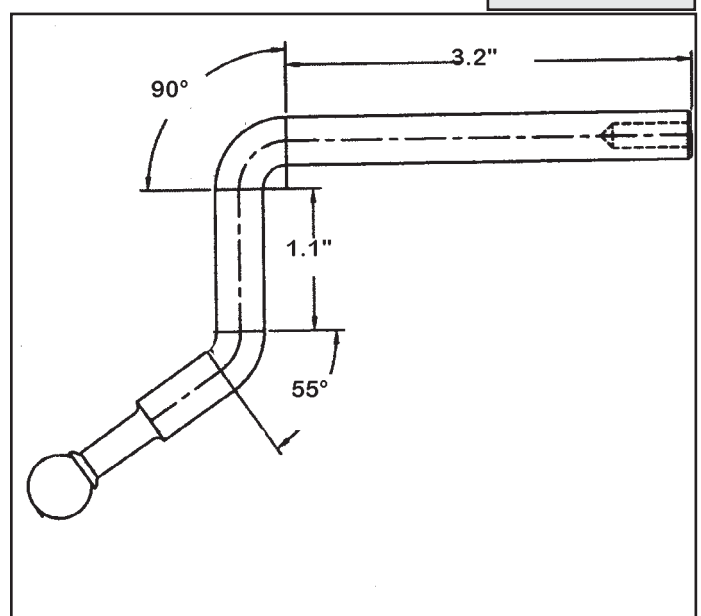
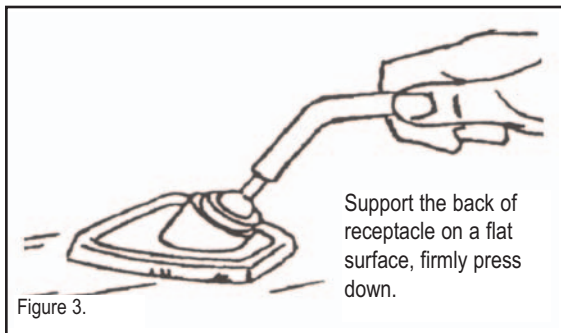

1. INSTALL ARMS INTO SOCKETS

Support the mounting receptacle of the Fairing Body on a firm, flat surface, and firmly press ball end of upper arms (3) into upper sockets. Ball will snap into place. Repeat for lower arms (4).

NOTE: If sockets are below 50° F., warm them with a hair dryer before installing arms. If lubricant is needed, use water or saliva only. Do not use oil, grease, silicone or other lubricants on the ball end rods or in the mount receptacles.

INSTALL HANDLEBAR CLAMPS, MOUNT FAIRING BODY AND WINDSHIELD

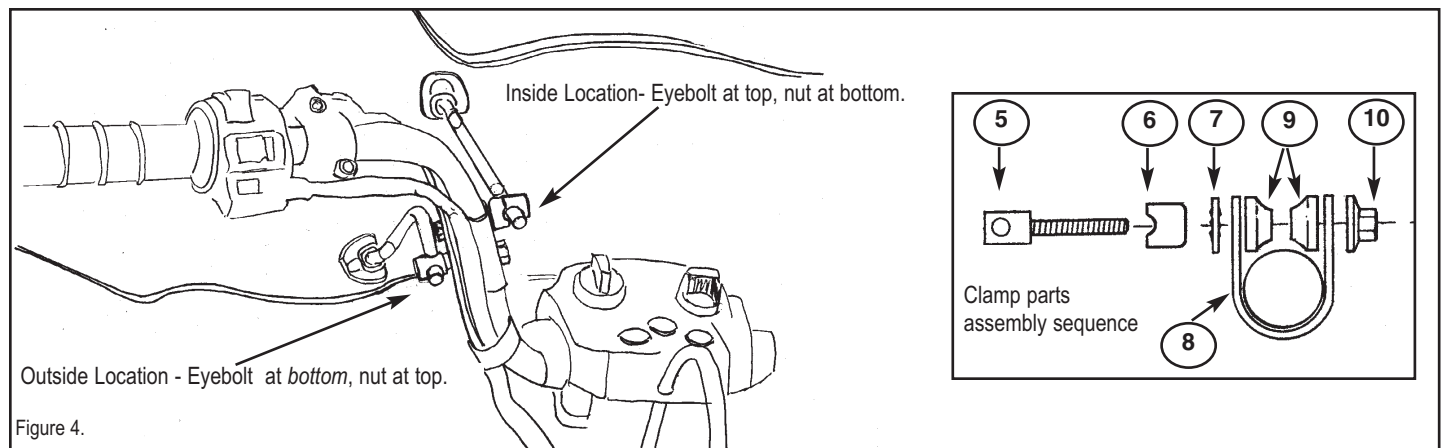

1. Install left side clamp assembly as shown. Install right side symmetrically opposite.

2. Mount fairing body in front of handlebar. Insert upper and lower arms into eyebolts as shown in figure 4. Adjust the fairing body to be horizontal and centered in front of the headlight. The forward edge of the fairing body should be about 3/8" above the rack. Make sure the brake levers have a minimum 1/2" clearance to the fairing body.

Fully tighten the eyebolt and whizlok nuts, checking fairing body alignment while proceeding.

3. Install Windshield. Hardware Bag 334

A.) Hold Windshield in place on the Fairing body.

B.) Start with the middle lower hole and insert a nylon screw through the screen from the outside. Secure with the whizlok nut. Repeat for all holes. Tighten firmly, do not over tighten.

4. Install Mirrors. Hardware Bag 332

From inside the fairing body install a mirror with flat washer and screw. Secure with whizlok nut on the outside of fairing. Tighten firmly.