



BB Socket Holder II

For Use With Splined BB Socket

PN 6460211
Made in Taiwan
Specifications subject to
change without notice.

Pedro's NA
P.O. Box 320635
Boston, MA 02132, USA

Pedro's Europe AB
Västra Granholmen 13
SE-18599 Vaxholm, Sweden

Supplies and Setup

- BB Socket Holder II
- Splined Bottom Bracket Socket (pn 6460201/6460202)
- Wrench: Pro Socket Handle, Adjustable Wrench, Equalizer Pedal Wrench (w/ 24mm Socket).
- Repair Stand (Optional)

Usage

The BB Socket Holder is used with Pedro's Splined BB Socket to remove Shimano® and ISIS Drive® splined bottom bracket cups, square taper bottom brackets, and other cartridge bottom brackets that feature cups with 20 internal splines. Always remove the non-drive side bottom bracket cup first.

For Splined Axles:

1. Disassemble BB Socket Holder.
2. Install the M15/M12 end of screw into BB spindle.
3. Install Splined BB Socket, washer, spring, and nut as shown. When spring begins compressing, tighten nut 2-3 more rotations to add preload.
4. Install wrench onto Spline BB Socket.
5. Start removing BB cup by turning wrench as shown. For non-drive side, do not loosen cup more than 3 rotations to prevent spring from bottoming. For drive side, continue rotating until cup/BB is removed and skip remaining steps.
6. For non-drive side only, remove wrench, BB Socket Holder, and BB Socket, then use only BB Socket and Wrench to complete cup removal.

For Square Taper Axles:

1. Disassemble BB Socket Holder. Put the nut aside. It will not be used.
2. Position the Splined BB Socket into the BB cup. Install washer, spring, and M8 end of screw through socket and thread into BB spindle. When spring begins compressing, tighten 2-3 more rotations to add preload.
3. Follow steps 4-6 for splined axles.

For Splined Axles

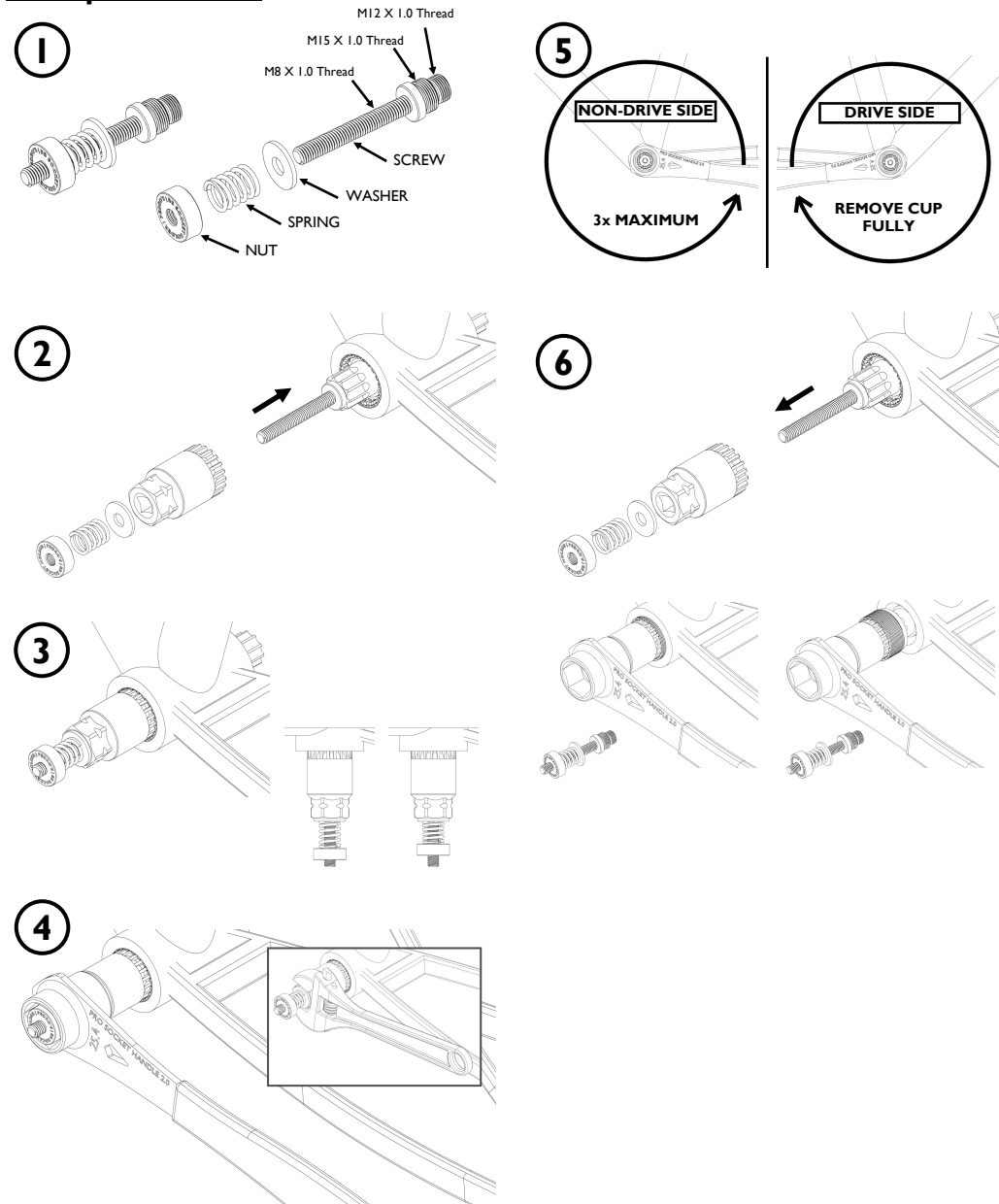

For Square Taper Axles

