

— PROPRIETARY —  
 THIS DOCUMENT CONTAINS CONFIDENTIAL, PROPRIETARY INFORMATION  
 THAT IS FOX PROPERTY. DO NOT DISCLOSE TO OR DUPLICATE  
 FOR OTHERS EXCEPT AS AUTHORIZED BY FOX.

# TURBINE DIRECT MOUNT AND DIRECT MOUNT WIDE SHI12 CRANK ASSEMBLY

REVISIONS				
ZONE	REV	DESCRIPTION	DATE	CHECKED
	A	INITIAL RELEASE	2022-09-06	JK DRB

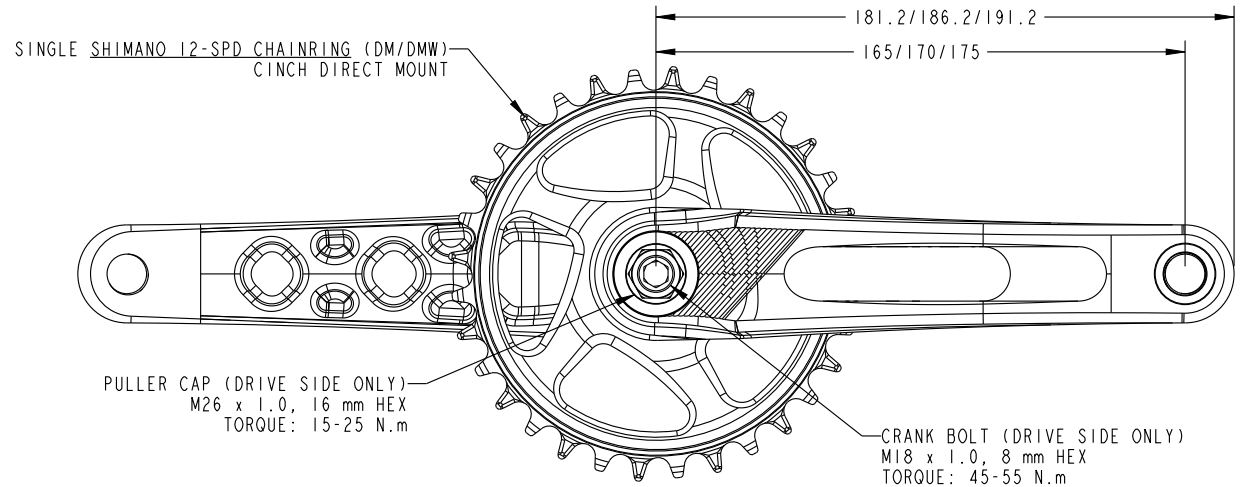

TABLE 1

# OF TEETH	CHAINRING RADIUS
30	64.8
32	68.8
34	72.8

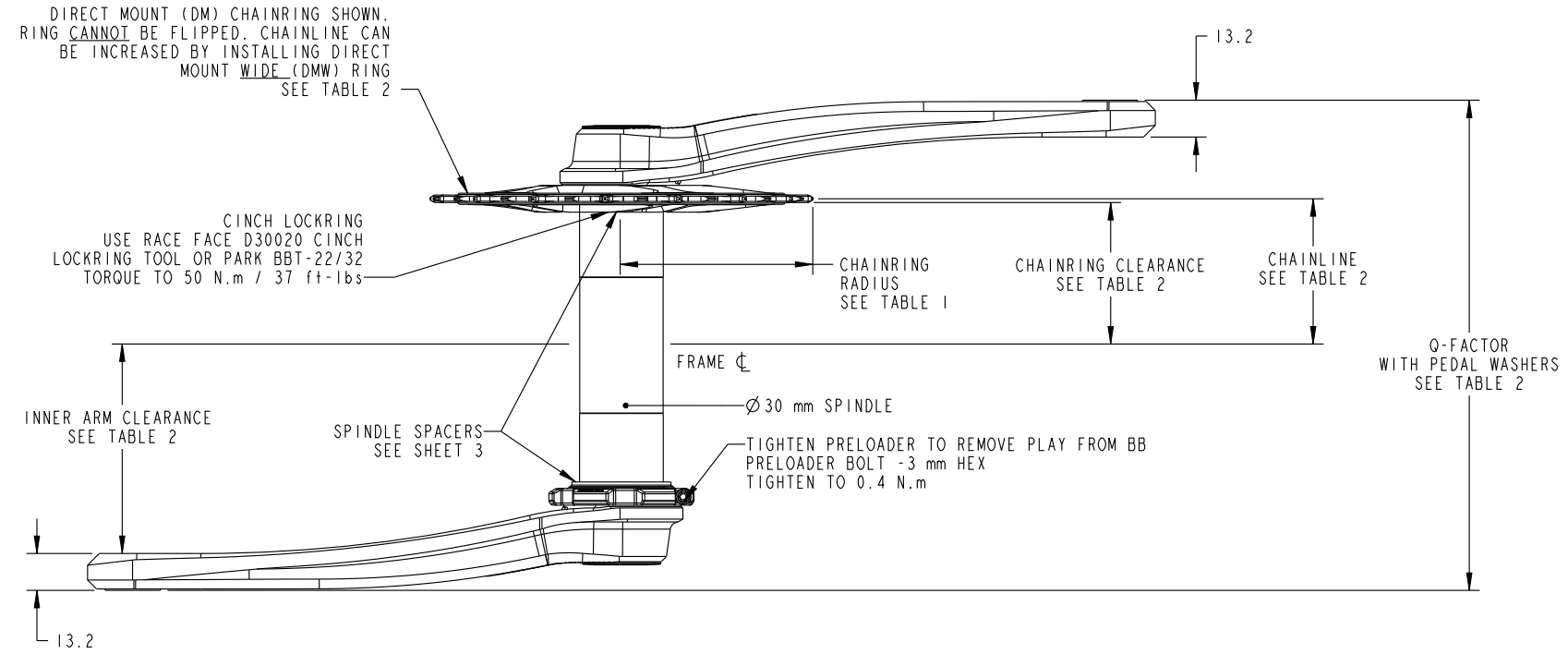
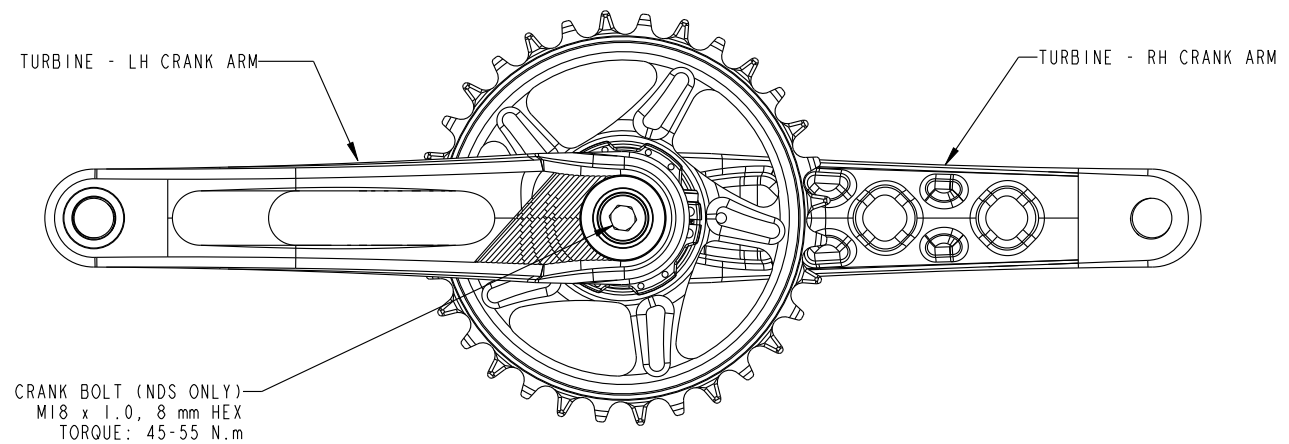

TABLE 2

SPINDLE	INTENDED BOTTOM BRACKET WIDTH	DM RING		DMW RING		INNER ARM CLEARANCE	Q-FACTOR
		INNER RING CLEARANCE	CHAINLINE	INNER RING CLEARANCE	CHAINLINE		
RF136	98.1	50.0	52.0	53.5	55.0	74.3	175
RF143	98.1	53.5	55.5	57.0	58.5	77.8	182
RF149	113.1	56.5	58.5	60.0	61.5	80.8	188
RF169	130.1	66.5	68.5	70.0	71.5	90.8	208
RF189	130.1	76.5	78.5	80.0	81.5	100.8	228



**FOX RACE FACE**  
**EASTON CYCLING**

**FOX FACTORY INC.**  
 SPECIALTY SPORTS GROUP  
 \*118 - 8333 EASTLAKE DRIVE  
 BURNABY BC, V5A 4W2

**CRANK, TURBINE, DM, NO BB - CUST**

SIZE	PART NO.	REVISION
B	Ock22TUR	A
PLOT SCALE	2:5	UNITS: mm
		SHEET 1 OF 3

# TURBINE DIRECT MOUNT 11-12 SPEED CRANK ASSEMBLY

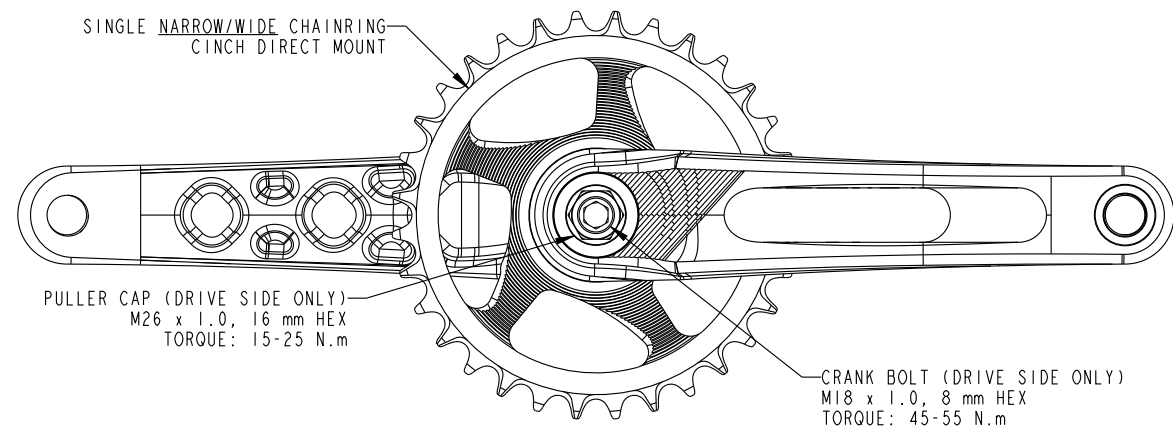

**TABLE 3**

# OF TEETH	CHAINRING RADIUS
24	51.7
26	55.5
28	59.6
30	63.6
32	67.7
34	71.7
36	75.8
38	79.8
40	83.8
42	87.8

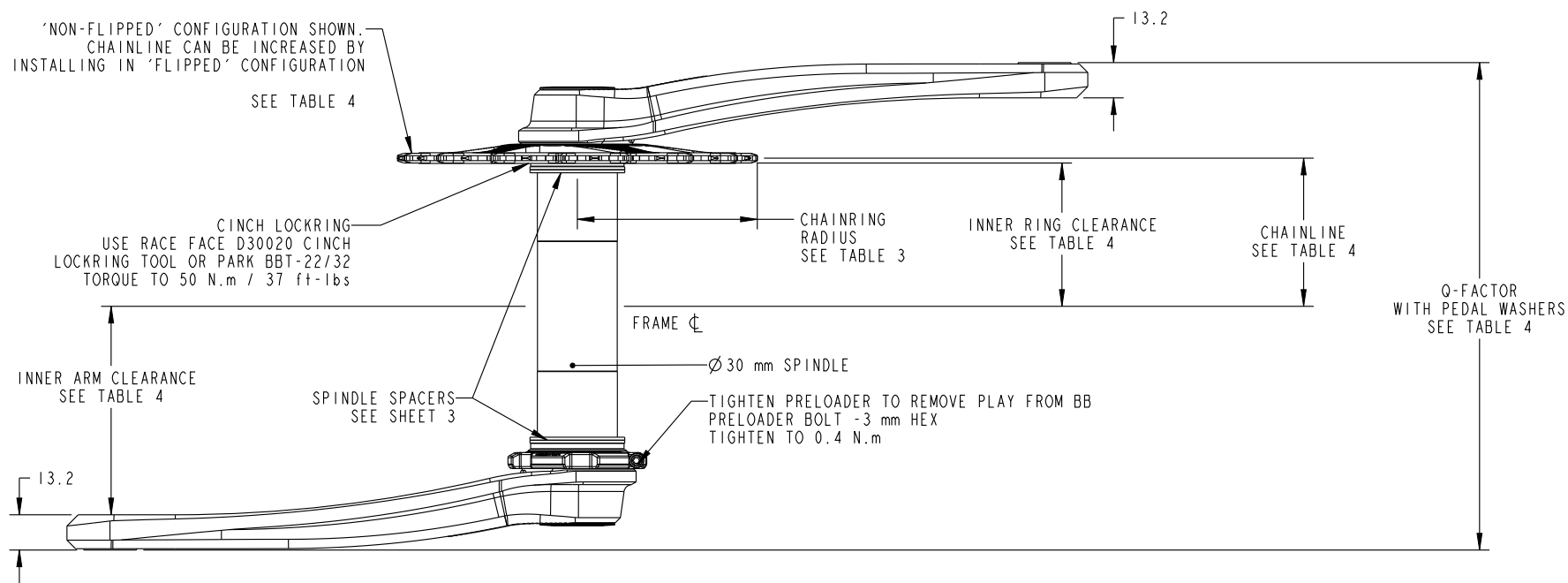

**TABLE 4**

SPINDLE	INTENDED BOTTOM BRACKET WIDTH	'NON-FLIPPED' RING		'FLIPPED' RING		INNER ARM CLEARANCE	Q-FACTOR
		INNER RING CLEARANCE	CHAINLINE	INNER RING CLEARANCE	CHAINLINE		
RF136	98.1	50.0	52.0	56.5	58.5	74.3	175
RF143	98.1	53.5	55.5	60.0	62.0	77.8	182
RF149	113.1	56.5	58.5	63.0	65.0	80.8	188
RF169	130.1	66.5	68.5	73.0	75.0	90.8	208
RF189	130.1	76.5	78.5	83.0	85.0	100.8	228

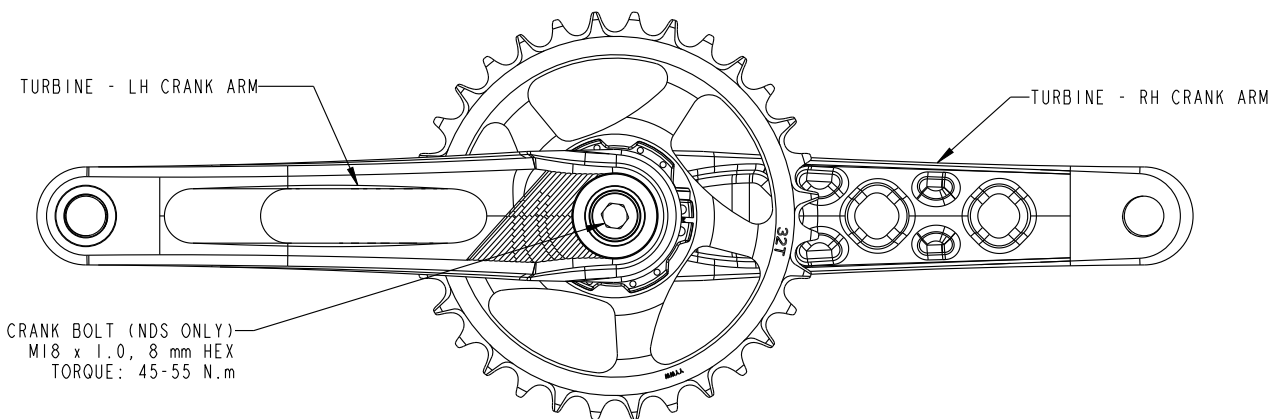

— PROPRIETARY —  
 THIS DOCUMENT CONTAINS CONFIDENTIAL, PROPRIETARY INFORMATION THAT IS FOX PROPERTY. DO NOT DISCLOSE TO OR DUPLICATE FOR OTHERS EXCEPT AS AUTHORIZED BY FOX.

SIZE B	CAGE NO. NONE	DWG. NO. OCK22TUR	REV. A
PLOT SCALE 2:5		UNITS: mm	2 OF 3

# SPACER CONFIGURATIONS

(BY SPINDLE LENGTH)

RF136 SPINDLE

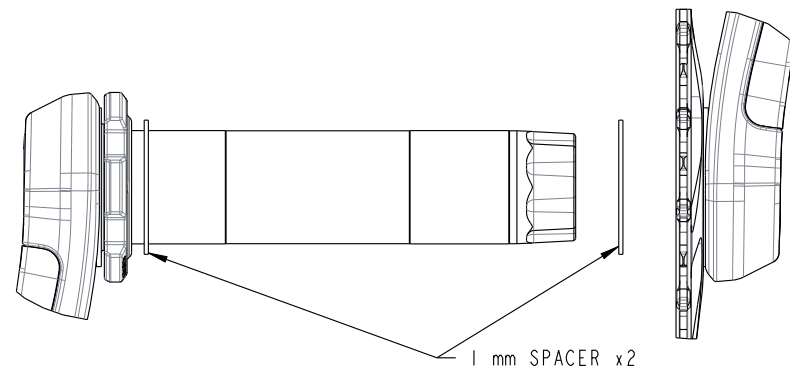

RF143 SPINDLE

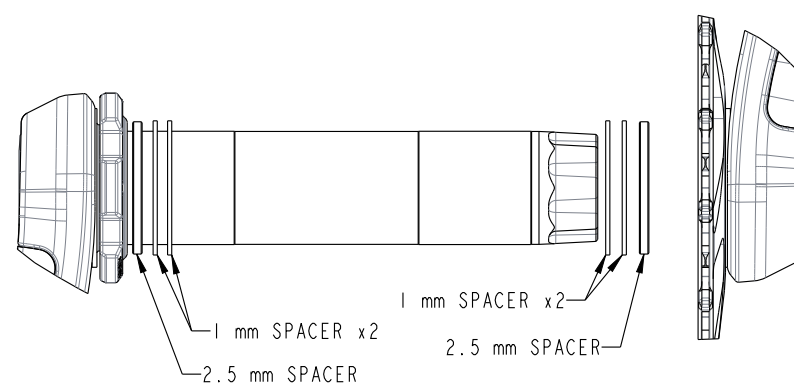

RF149 SPINDLE

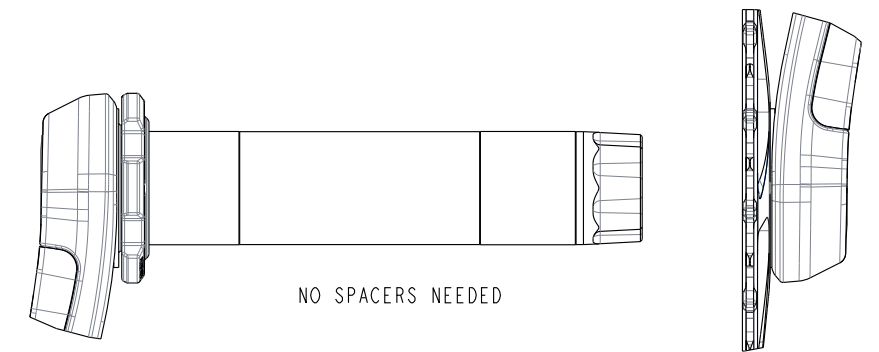

RF169 SPINDLE

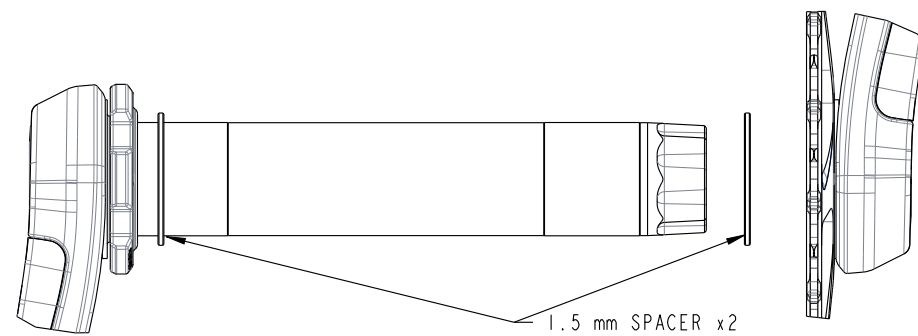

RF189 SPINDLE

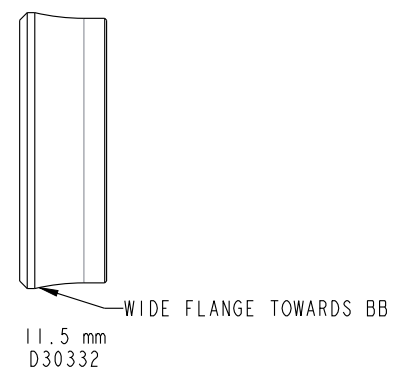
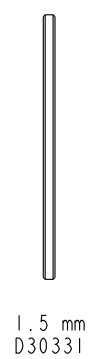
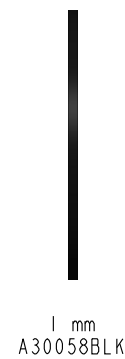
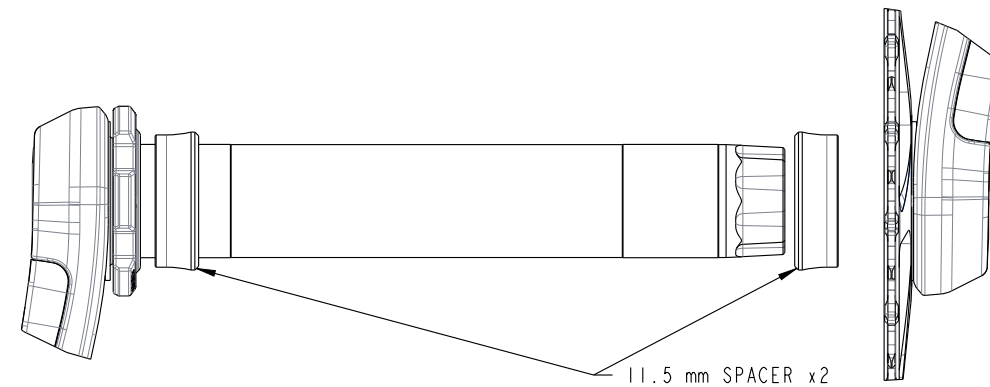

SCALE 1:1

— PROPRIETARY —  
THIS DOCUMENT CONTAINS CONFIDENTIAL, PROPRIETARY INFORMATION THAT IS FOX PROPERTY. DO NOT DISCLOSE TO OR DUPLICATE FOR OTHERS EXCEPT AS AUTHORIZED BY FOX.

SIZE B	CAGE NO. NONE	DWG. NO. OCK22TUR	REV. A
PLOT SCALE	1:2	UNITS: mm	3 OF 3