

# rockymounts Hitch Rack Comparison Chart



**BackStage**  
Swing Away Platform Hitch Rack



**SplitRail LS**  
Two Bike Platform Hitch Rack



**MonoRail**  
Two Bike Platform Hitch Rack



**MonoRail Solo**  
Single Bike Platform Hitch Rack



**WestSlope**  
Two Bike Hitch Rack



**WestSlope 3**  
Three Bike Hitch Rack



Number of Bikes	2	2	2	1	2	3
Expandable	X	Yes, to 3 or 4 bikes	Only 2" Model, to 3 bikes	Yes, to 2 bikes	X	X
Max weight Per Bike	60 lbs	60 lbs	60 lbs	60 lbs	40 lbs	40 lbs
Expanded Weight Per Bike	N/A	45 lbs	45 lbs	45 lbs	N/A	N/A
Hitch Sizes Available	2" Only	2" only	Dedicated 1.25" or 2"	1.25" and 2"	1.25" and 2"	2" Only
Maximum Tire Width	5"	3"	5"	5"	3"	3"
Wheel Base	34" to 49"	34" to 50"	36" to 50"	36" to 50"	36" to 50"	36" to 50"
Min/Max Wheel Size*	20" to 29"	20" to 29"	20" to 29"	20" to 29"	20" to 29"	20" to 29"
Bike Lock	Cable	Integrated Cable	Cable	Cable	Sold Separately	Sold Separately
Locks Rack to Vehicle	Yes	Yes	Yes	Yes	Sold Separately	Sold Separately
180° Swing Away	Yes	X	X	X	X	X
Folds Down 30°	Yes	Yes	Yes	Yes	Yes	Yes
Anti-Wobble	Premium 3-Axis	Premium 3-Axis	2-Axis	2-Axis	2-Axis	2-Axis
Rack Weight	59 lbs	44 lbs	39 lbs	25 lbs	36 lbs	43 lbs
MSRP	\$769.95	\$679.95	\$539.95	\$539.95	\$359.95	\$439.95

\*With a 20" wheel, minimum tire width is 2"

# SwingOut

The BackStage is the only swing away platform hitch rack on the market that is integrated and swings out a full 180 degrees.

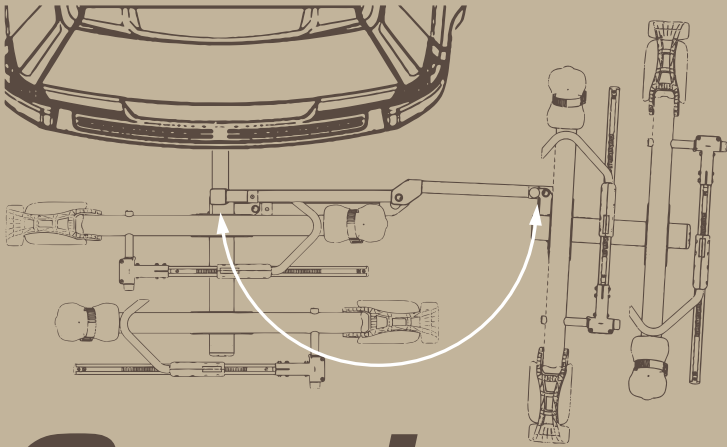

# Coatings

All RockyMounts Hitch Racks utilize a dual coating system on Steel components. This is comprised of an ED (Electro-Deposition) inner coating and an outer powder coating rated for 5 years. This adds an addition layer of weather protection both inside and out.

# Sliding Trays

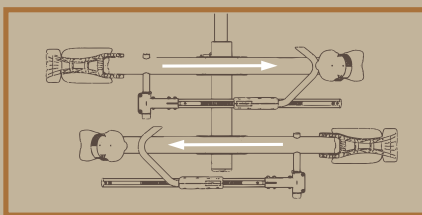
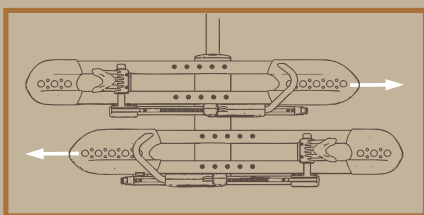

# Security

We Include locks with most of our hitch rack lineup.

The SplitRail LS has integrated and hidden cable locks in the load arms of the rack, which allow each bike to be locked individually.

The BackStage and MonoRail Family use an external cable that can be lassoed through the bike frames and around the the outermost bike then locked directly to the rack.

The WestSlope family utilizes a cable kit that can be purchased separately, using the same cable system as the BackStage and MonoRail.

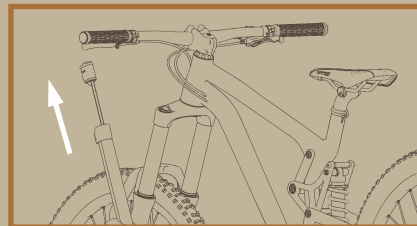

SplitRail Integrated Locks

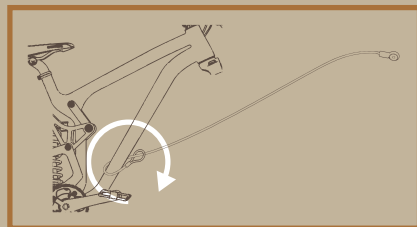
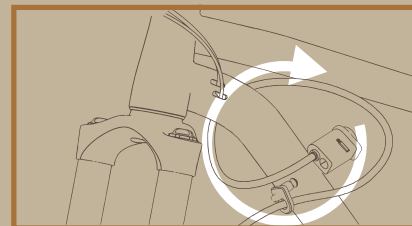

BackStage, MonoRail, and WestSlope Lock Kit

# Pivot Positions

Our hitch racks have three main pivot positions. Stowed (Vertical), Use (carrying bikes), and an open position which allows the racks to pivot an additional 30 degrees to allow access to the rear of the vehicle.

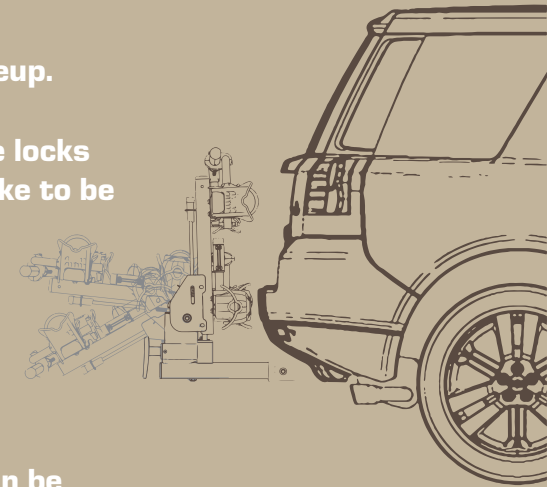

# Adaptability

The MonoRail Solo and WestSlope 2 Bike Rack are able to be used on both 1.25" and 2" hitch receivers with the included adapter.

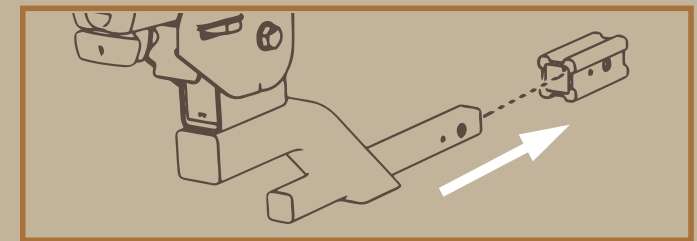

The SplitRail, BackStage, and MonoRail Family are capable of sliding the trays left or right in order to avoid handlebar to saddle interference.

# rockymounts

rockymounts.com - 303.402.0190  
1675 Las Colonias Dr. Grand Junction, CO 81501