

Saddlemen™

INSTALLATION INSTRUCTIONS

www.saddlemen.com

TEARDROP SPECIFIC-FIT SADDLEBAGS

3501-0495
3501-0496



FEATURES OF THE SADDLEMEN SADDLEBAGS:

- Quality luggage system that adds style and function to your motorcycle
- Bag shape and mounts specially built to fit your motorcycle - rigid bag construction holds its shape even when empty
- All mounting hardware and instructions are included
- Chromed metal supports fit behind each bag for extra strength and security, and are easily removed when bags are not in use
- Lockable, quick-release, hidden buckles under lid straps are easy to use, protect the contents and prevent unauthorized removal
- Can be upgraded to the QTL (Quarter Turn Locking) quick release mounting hardware for fast removal
- Waterproof - cleans easily with a damp cloth

⚠ WARNING

READ THESE INSTRUCTIONS THOROUGHLY BEFORE INSTALLATION!

Because of the variety of motorcycle configurations, other accessories, and the features and intended use of this Saddlemen accessory, there are many different mounting options. You are responsible for the proper installation of this accessory on your motorcycle. Your attention to these installation instructions and recommendations will permit safe and proper use of this accessory. You must mount this accessory properly and securely before riding your motorcycle. If you lack the ability to safely and properly install this accessory, seek out a qualified motorcycle technician for assistance. During installation, support the motorcycle with a suitable stand or lift so it will not tip over and injure you, or damage the vehicle. Using or mounting this accessory improperly could result in a loss of control of the motorcycle which could result in damage to your motorcycle or other personal property, the property of third parties, and/or personal injury to yourself or others, up to and including death.

BE SURE TO THOROUGHLY READ AND CLOSELY FOLLOW THE MOUNTING INSTRUCTIONS THAT ARE INCLUDED WITH THIS ACCESSORY:

- The saddlebags must be installed and securely fastened onto the frame or similar foundation on the motorcycle.
- Install the saddlebags securely so they will not shift or move while riding. Make sure the mounting hardware will not contact the wheels, suspension or any other moving parts of the motorcycle.
- If you do not understand the mounting instructions DO NOT mount the saddlebags. Remove the base or any components you may have already installed on your motorcycle.
- Thoroughly inspect your motorcycle luggage before every ride. Do not use the saddlebags if the mounting system has been modified, has deteriorated, loosened or is beginning to fail.
- Before riding, secure your cargo inside the saddlebags and completely close the lids/flaps.
- Continually check the security of the saddlebags at each stop as you ride. Hardware can loosen during operation, so be sure to check it frequently.
- Do not use this accessory if you have any doubts as to whether it is properly mounted to your motorcycle.
- Do not exceed 10 pounds of total weight of the combined weight of the saddlebag and its contents.
- Do not transport or store flammable or potentially explosive materials in your saddlebags.
- When using this accessory, do not exceed your vehicle's Maximum Gross Vehicle Weight as listed on your motorcycle or in the manufacturer's owner's manual.
- If your saddlebags are ever damaged, do not use them until they have been inspected by your local professional motorcycle dealer. Replace the saddlebags immediately if they have damage that prevents them from being properly secured to your motorcycle or from securely holding their contents.

DO NOT ATTEMPT TO USE THIS ACCESSORY IF:

- You do not understand these installation and use instructions,
- You do not understand any part of the accessory mounting system,
- You have any doubts as to the security of the mounting system.

If you have any concerns or questions, seek help at your qualified motorcycle dealer or call the Saddlemen support line at (310) 638-1222.

Remember: Motorcycling can be a dangerous activity. Installation of any accessory can increase your risk if it is not installed properly. You are responsible to install this accessory so it will not contact any portion of the drive train, suspension or steering, and so it will in no way interfere with the operation of your motorcycle.

PARTS INCLUDED WITH THE SADDLEBAGS:

Part	Qty.
Saddlebags (not shown)	2
Saddlebag supports	2
Rubber grommets	4
Spacer, plastic	4
Spacer, metal	4
Bolts, 80 x 8mm	4
Washers, 1.25" diameter - 9mm ID	8
Support bracket hooks	2
Support bracket backing plates	2
3/16 x 1/2" Phillips-head screws	4
3/16" lock nuts	4
Keys for quick-release buckles (not shown)	2
Instruction set (not shown)	1



The vehicle images in this instruction set may be different than your motorcycle.

Continued on next page...



INSTALLATION INSTRUCTIONS:

Saddlemen Teardrop Specific-Fit Saddlebags mount to the fender struts of your motorcycle using the supplied saddlebag supports (1) and mounting hardware. The fender strut (2) is the component of your motorcycle that attaches the rear fender to the frame.

IMPORTANT:

For your safety, and the protection of your motorcycle and saddlebags, it is essential that you install the saddlebag supports properly. Both supplied supports must be installed in a way that prevents the saddlebags from interfering with any part of the motorcycle's operation, including the turn signals, tail or brake lights, exhaust system, suspension, or the drive train. You (or your professional motorcycle technician) will need to determine the best mounting configuration for your motorcycle.

NOTE:

Your VL800 or C50 does not require turn signal relocation as the signals are mounted on the rear fender, adjacent to the tail light.

TIP:

To simplify the mounting of the saddlebags, Saddlemen recommends you work on one side of your motorcycle at a time, completing the full installation on the first side before beginning the second side. This will help you maintain fender and saddlebag alignment and make it easier to install the fender strut bolts and other mounting hardware that is exchanged during the installation.

The saddlebag supports are hinged (3) so they can adjust to any variance in your motorcycle's fender strut bolt locations. The supports have a one-inch offset (4) that angles the supports outward so they space the bags away from the motorcycle's chassis components, wheels, brakes, and moving parts.

Before removing or changing any hardware, hold the supports next to the motorcycle to familiarize yourself with how they will be installed. Remove the original fender mounting bolts from one side of the fender strut and temporarily mount one support with a 8mm bolt, a plastic and steel spacer, and two washers into each fender stay bolt hole. Verify that each bolt is the proper length.

IMPORTANT:

When installing a bolt into the fender strut, check to be sure that it does not extend inside the fender further than the original fasteners. If it does, the excess length of the bolt must be cut off, or exchanged for a shorter bolt you obtain from the hardware store or a motorcycle shop.

After verifying the mounting bolts are the proper length, remove the support from the motorcycle's fender strut.

Install a grommet in each of the large holes (5) on the back side of each saddlebag. Then insert a plastic spacer (6) in each of the grommets.

TIP:

Use soapy water to lubricate the grommets so they will slip into the holes in the bag.

Lay a support (7) (with the joint towards the rear of the bag) on the back of a bag. Temporarily put the mounting bolts (8) through the support's holes and into the plastic spacers in the grommets.

Place one of the support clips (9) over the center of the lower portion of the support, so the two holes in the clip align with the predrilled holes in the bag.

Use the 3/16" screws and nuts from the hardware kit to attach the support clip to the backup plate inside the bag. Place the nuts on the outside of the bag. Do not over-tighten the hardware, as this may cause damage to the saddlebag. Remove the mounting bolts from the support and the plastic spacers.

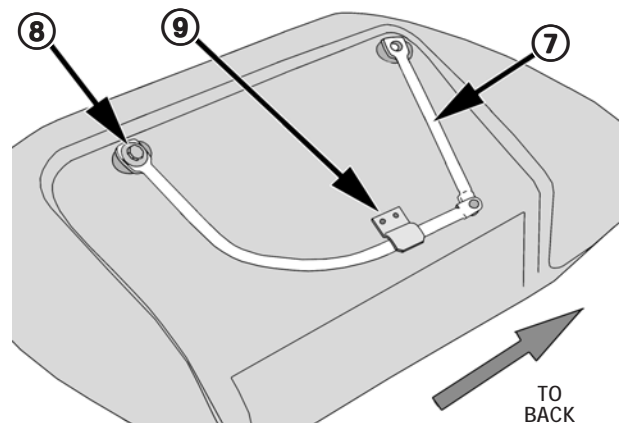
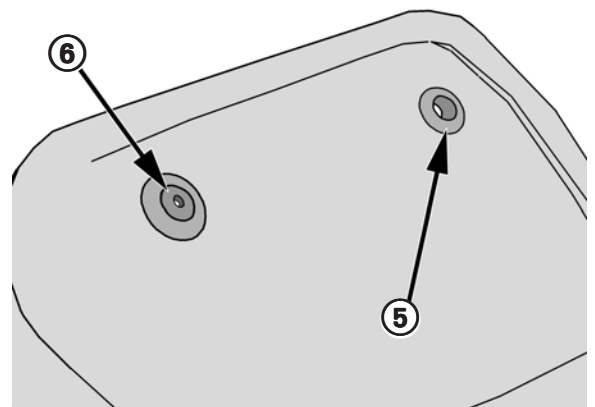
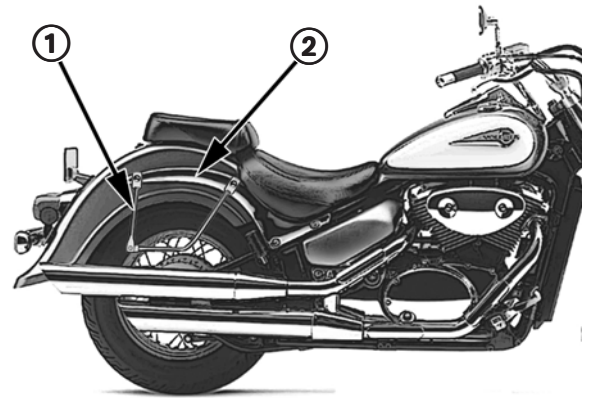

The vehicle images in this instruction set may be different than your motorcycle.

Continued on next page...

INSTALLATION INSTRUCTIONS (continued):

Install the saddlebag with the mounting hardware in this order:

- ⑩ Fender stay (mounted to rear fender & frame)
- ⑪ Steel spacer
- ⑫ Support
- ⑬ Washer
- ⑭ Plastic spacer (goes inside of rubber grommet)
- ⑮ Rubber grommet (inserted into the saddlebag)
- ⑯ Saddlebag
- ⑰ Washer
- ⑱ Bolt

NOTE:

Be sure to tighten the mounting bolts securely.

When installing a bolt through the saddlebag, supports and fender, check to be sure that it does not extend inside the fender further than the original fastener. If the bolt is too long, it must be cut off or exchanged for a shorter bolt you obtain from a hardware store or motorcycle shop.

Repeat the same steps for the other saddlebag ⑲.

Check and adjust the alignment, and tighten all of the bolts securely. Use a thread locking agent (such as Loctite™) on the support mounting hardware during final assembly.

NOTE:

Review and follow the NOTES and IMPORTANT comments in this instruction sheet, especially checking for support and saddlebag clearance as the motorcycle's suspension moves through its entire range of motion.

QUICK-RELEASE & LOCKING BUCKLES:

Saddlemen Teardrop Specific-Fit Saddlebags feature quick-release buckles ⑳ under the lid strap's "conventional" buckles. This permits fast access to the inside of the bag. To aid in securing your belongings inside the bag, each quick-release buckle has a lock ㉑ that can be locked using the keys that are include with your saddlebag set.

TIP:

Keep one of your saddlebag keys in a safe place, like your motorcycle's tool kit, in case you misplace the other key.

OPTIONAL QUICK DISCONNECT DOCKING POST KIT:

for Suzuki VL800, C50 and similar models (Saddlemen #3501-0337):

You can add the ability to remove and reinstall the saddlebags on your motorcycle in seconds, with the Quick Disconnect Docking Post Kit ㉒.

The kit has docking posts and fasteners that replace the fender mounting bolts and plastic spacers to allow you to put on or take off your saddlebags with a quick twist of the QTL (Quarter Turn Locking) fasteners. Each kit has four docking posts with the required fasteners, spacers, grommets, support clips, nuts, bolts and instructions.

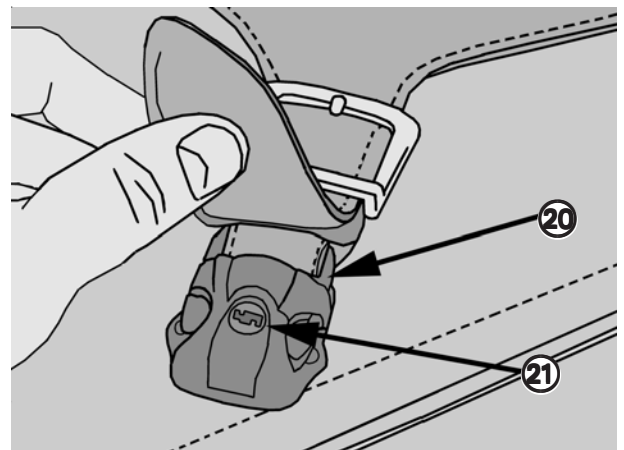
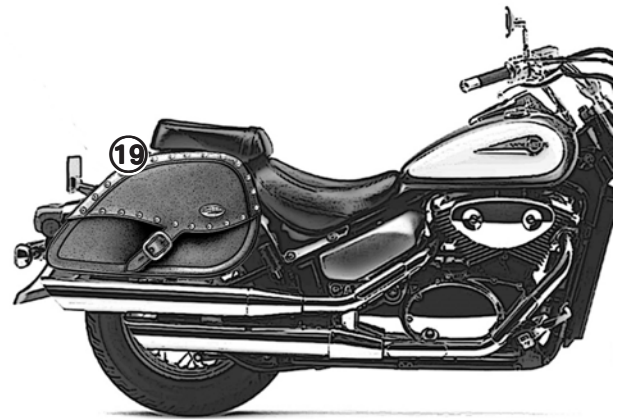
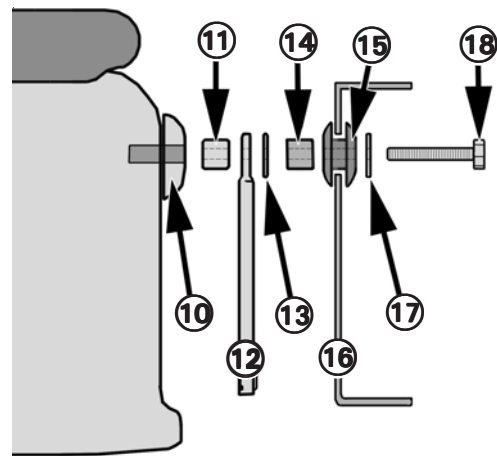

The vehicle images in this instruction set may be different than your motorcycle.

Continued on next page...

IMPORTANT:

Failure to install this accessory properly may allow portions of the saddlebags or their mounting materials to contact the vehicle's moving parts. It is vital that you verify that the accessory and/or any of its parts will not touch, or interfere with other components while the suspension moves through its entire range of motion.

Make sure that your saddlebags or mounting hardware does not touch the exhaust or other non-moving components, as well, as they may be damaged from contact with the accessory.

Occasionally, the configuration of this accessory with certain motorcycles may require relocation and/or adjustment of certain components on the vehicle. Check to be sure that all lights and safety reflectors are visible once the saddlebags are in place. If the saddlebags or mounting hardware blocks any side reflectors, place reflectors on the exterior sides of the saddlebags (reflectors with self-adhesive backing are available from motorcycle or automobile supply stores). It is your responsibility to make sure the installation does not create an unsafe or illegal condition.

After 50 miles (80 kilometers), recheck all of the mounting hardware and the saddlebags to make sure they are still tight and secure. Inspect the saddlebags and related hardware before and during each ride. A loose saddlebag or hardware can interfere with the vehicle's operation and cause an unsafe riding condition.



CARE OF YOUR SADDLEMEN SADDLEBAGS:

Your Saddlemen Saddlebags require almost no maintenance, other than periodic cleaning.

Use Saddlemen Seat & Saddlebag Ultra Wash (#3101) for the best results while cleaning fabric covered saddlebags, or use mild soap and water. Use Saddlemen Seat & Saddlebag Conditioner (#3102) for the best results while cleaning vinyl covered saddlebags.

Protect the finish and enhance the appearance of your fabric or vinyl saddlebags with Saddlemen's Seat & Saddlebag Fabric Conditioner (#3103).



SADDLEMEN LIMITED ONE-YEAR WARRANTY

Saddlemen warrants its products for defects in materials, design or workmanship for a period of one year after retail purchase. Items that are defective will be repaired or replaced by Saddlemen at its sole discretion. Damage caused by improper use or improper installation is not a defect; therefore repair or replacement of a damaged accessory will not be covered under this warranty. This warranty contains other provisions and conditions, so please visit www.saddlemen.com for additional information. Thank you for purchasing your new Saddlemen Saddlebags. You can count on Saddlemen's quality, innovation, service and style. We want you to be completely satisfied. If you have any comments, or are not satisfied with the performance of your Saddlemen accessory, please contact the Saddlemen support line at (310) 638-1222.

