

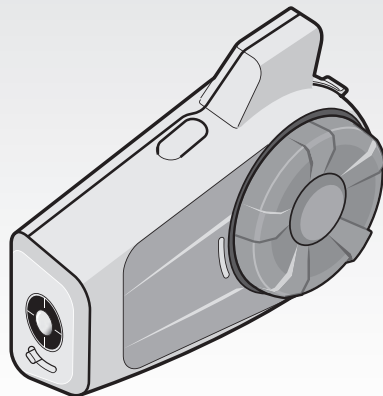

# 10C EVO

Motorcycle Bluetooth®  
Camera & Communication System



© 1998-2021 Sena Technologies, Inc. All rights reserved.

Sena Technologies, Inc. reserves the right to make any changes and improvements to its product without providing prior notice.

Sena™ is a trademark of Sena Technologies, Inc. or its subsidiaries in the USA and other countries. SF1™, SF2™, SF4™, SFR™, SRL™, Momentum™, Momentum INC™, Momentum Lite™, Momentum Pro™, Momentum INC Pro™, Momentum EVO™, Cavalry™, Latitude SR™, Latitude SX™, Latitude S1™, 30K™, 33i™, 50S™, 50R™, 50C™, 5S™, 20S EVO™, 20S™, 10S™, 10C™, 10C PRO™, ProRide EVO™, 10C EVO™, 10U™, 10Upad™, 10R™, ACS10™, C1™, 3S™, 3S PLUS™, SMH5™, SMH5-FM™, SMH5 MultiCom™, SMH10™, SMH10R™, SPH10™, SPH10H-FM™, Savage™, Prism Tube WiFi™, Prism™, Bluetooth Audio Pack for GoPro®, Impulse™, R1™, R1 EVO™, R1 EVO CS™, R2™, R2 EVO™, R2X™, M1™, M1 EVO™, RUMBA™, RC1™, RC3™, RC4™, Stryker™, Handlebar Remote™, Wristband Remote™, PowerPro Mount™, Powerbank™, FreeWire™, WiFi Docking Station™, WiFi Sync Cable™, WiFi Adapter™, +mesh™, +Mesh Universal™, MeshPort Blue™, MeshPort Red™, MeshPort Black™, Econo™, OUTRUSH™, OUTRUSH R™, OUTSTAR™, OUTSTAR S™, OUTFORCE™, OUTRIDE™, EcoCom™, Parani A10™, Parani A20™, Parani M10™, pi™, Snowtalk™, Snowtalk2™, SR10™, SR10i™, SM10™, SPIDER RT1™, SPIDER ST1™, X1™, X1 Pro™, X1S™, Expand™, Expand Boom™, Bluetooth Mic & Intercom™, Tufftalk™, Tufftalk Lite™, Tufftalk M™ are trademarks of Sena Technologies, Inc. or its subsidiaries. These trademarks may not be used without the express permission of Sena.

GoPro® is a registered trademark of Woodman Labs of San Mateo, California. Sena Technologies Inc. (“Sena”) is not affiliated with Woodman Labs. The Sena Bluetooth Pack for GoPro® is an after-market accessory specially designed and manufactured by Sena Technologies, Inc. for the GoPro® Hero3 allowing for Bluetooth capabilities.

The Bluetooth® word mark and logos are owned by the Bluetooth SIG, Inc. and any use of such marks by Sena is under license. iPhone, iPod touch are registered trademarks of Apple Inc. Zumo™ is a trademark of Garmin Ltd. or its subsidiaries. TomTom™ is the trademark or registered trademark owned by TomTom International B.V. Other trademarks and tradenames are those of their respective owners.

# CONTENTS

<b>1</b>	<b>PACKAGE CONTENTS</b> .....	<b>4</b>
<b>2</b>	<b>INSTALLING THE HEADSET ON YOUR HELMET</b> .....	<b>5</b>
2.1	Installing the Main Unit .....	5
2.2	Installing the Speakers .....	7
2.3	Installing the Microphone .....	8
2.4	Adjusting the angle .....	10
<b>3</b>	<b>GETTING STARTED</b> .....	<b>11</b>
3.1	Product Details .....	11
3.2	Powering On and Off .....	11
3.3	Low Battery Warning .....	11
3.4	Charging .....	11
3.5	Checking the Battery Level .....	12
3.6	Volume Adjustment .....	12
3.7	Sena Softwares .....	12
<b>4</b>	<b>CAMERA OPERATION</b> .....	<b>13</b>
4.1	Camera On or Off .....	13
4.2	Camera Modes .....	13
4.3	Video Recording .....	14
4.4	Video Mode (Default: Normal Recording Mode) .....	14
4.5	Photo Taking .....	15
4.6	Video Tagging .....	15
4.7	Format SD Card .....	16
4.8	WiFi Channel (Default: 5 GHz) .....	16
<b>5</b>	<b>PAIRING THE HEADSET WITH BLUETOOTH DEVICES</b> .....	<b>16</b>
5.1	Mobile Phone Pairing - Mobile Phone, Bluetooth Stereo Device .....	16
5.2	Second Mobile Phone Pairing - Second Mobile Phone, GPS, and SR10 .....	17
5.3	Advanced Selective Pairing: A2DP Stereo or Handsfree .....	17
5.4	Intercom Pairing .....	18
<b>6</b>	<b>MOBILE PHONE, GPS</b> .....	<b>19</b>
6.1	Mobile Phone Call Making and Answering .....	19
6.2	Speed Dialing .....	19
6.3	GPS Navigation .....	20
<b>7</b>	<b>STEREO MUSIC</b> .....	<b>20</b>
7.1	Bluetooth Stereo Music .....	20
7.2	Music Sharing .....	21
<b>8</b>	<b>INTERCOM</b> .....	<b>21</b>
8.1	Two-way Intercom .....	21
8.2	Multi-Way Intercom .....	22
<b>9</b>	<b>THREE-WAY CONFERENCE PHONE CALL WITH INTERCOM PARTICIPANT</b> .....	<b>23</b>
<b>10</b>	<b>GROUP INTERCOM</b> .....	<b>24</b>
<b>11</b>	<b>UNIVERSAL INTERCOM</b> .....	<b>24</b>
<b>12</b>	<b>FUNCTION PRIORITY</b> .....	<b>25</b>
<b>13</b>	<b>CONFIGURATION SETTING</b> .....	<b>26</b>
13.1	Headset Configuration Setting .....	26
13.2	Software Configuration Setting .....	27
13.3	Camera Configuration Setting .....	30
<b>14</b>	<b>FIRMWARE UPGRADE</b> .....	<b>32</b>
<b>15</b>	<b>TROUBLESHOOTING</b> .....	<b>32</b>
15.1	Fault Reset .....	32
15.2	Factory Reset .....	33

# 1 PACKAGE CONTENTS

- **Headset Main Unit**



- **Gear Clamp Unit**



- **Clamp Unit**



- **Glued Surface Mounting Plate**



## Speaker

- **Speakers**



- **Hook and Loop Fasteners for Speakers (2)**



- **Speaker Pads (2)**



## Attachable Boom Microphone

- **Attachable Boom Microphone**



- **Microphone Sponges (2)**



- **Hook and Loop Fastener for Attachable Boom Microphone**



- **Boom Microphone Holder**



- **Hook and Loop Fastener for Boom Microphone Holder**



## Wired Microphone

- **Wired Microphone**



- **Hook and Loop Fastener for Wired Microphone**



## Others

- **USB Power & Data Cable**



- **Allen Wrench**



## 2 INSTALLING THE HEADSET ON YOUR HELMET

### 2.1 Installing the Main Unit

#### 2.1.1 Using the Gear Clamp Unit

1. Loosen the two screws on the back plate of the clamp unit with the included allen wrench.
2. Insert the back plate of the clamp unit between the internal padding and external shell of the left side of the helmet.
3. Tighten the two screws until the clamp unit is fastened firmly to the helmet.
4. Insert a microSD card into the card slot to use camera.
5. Attach the main unit to the clamp unit until you hear a click.

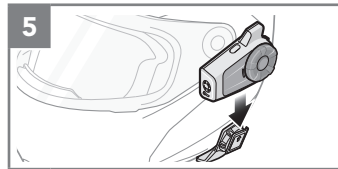
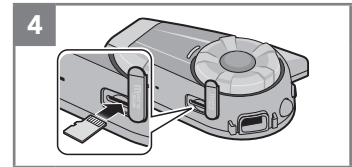
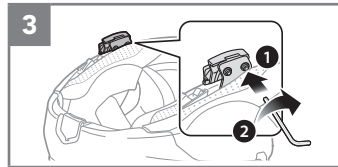
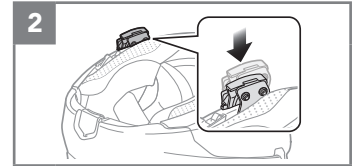
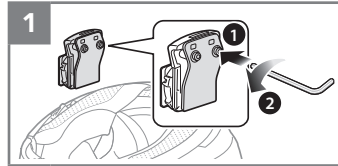

### 2.1.2 Using the Clamp Unit

1. Loosen the two screws on the back plate of the clamp unit with the included allen wrench.
2. Insert the back plate of the clamp unit between the internal padding and external shell of the left side of the helmet.
3. Tighten the two screws until the clamp unit is fastened firmly to the helmet.
4. Insert a microSD card into the card slot to use camera.
5. Attach the main unit to the clamp unit until you hear a click.

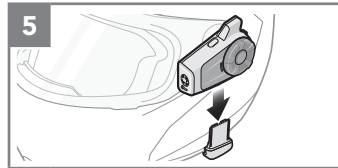
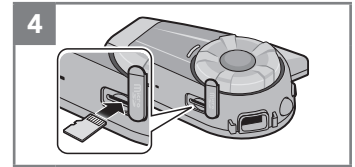
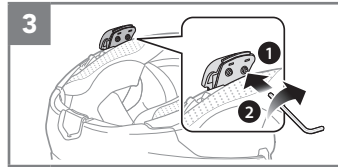
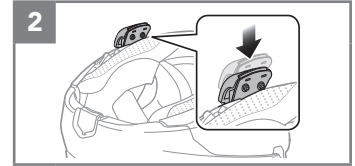
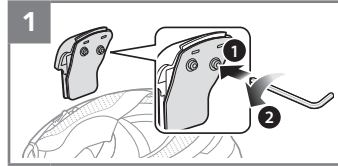

### 2.1.3 Using the Glued Surface Mounting Plate

If you cannot install the clamp unit on the helmet, you can use the glued surface mounting plate to attach the clamp unit to the surface of the helmet.

1. Attach adhesive tape of the glued surface mounting plate to the helmet.
2. Make sure that the glued surface mounting plate sticks on the helmet firmly. Maximum adhesion occurs after 24 hours.
3. Attach the main unit to the glued surface mounting plate until you hear a click.

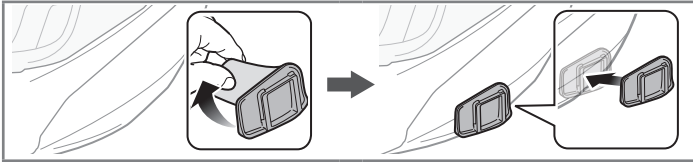

### 2.2 Installing the Speakers

1. Attach the hook and loop fasteners for speakers to ear pockets inside the helmet.
2. Attach the speakers to the hook and loop fasteners for speakers inside the helmet.

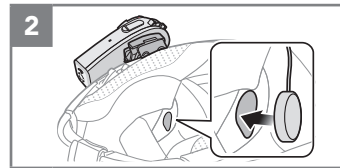
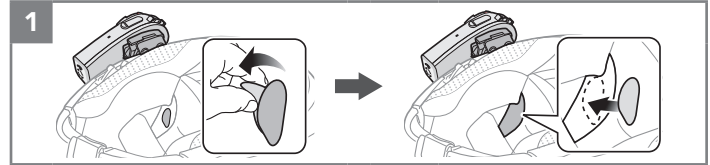

## 2.3 Installing the Microphone

### 2.3.1 Using the Attachable Boom Microphone

1. Attach the hook and loop fastener for attachable boom microphone on the inside surface of the left external shell.
2. Attach the attachable boom microphone's mounting plate to the hook and loop fastener.
3. Adjust the head of the microphone so that the tab is facing away from your mouth.
4. Align the arrows on the microphone and speaker cables and insert the microphone cable into the speaker cable.
5. Insert the speaker connector into the speaker port to connect it to the main unit.
6. Close the cover of the speaker cable to lock the cable to the port.

*Note:*

*You can use the boom microphone holder after attaching the hook and loop fastener for boom microphone holder on it to ensure secure installation.*

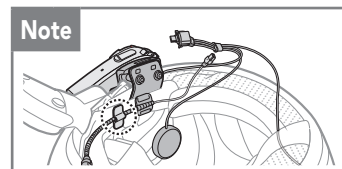
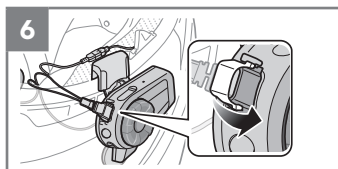
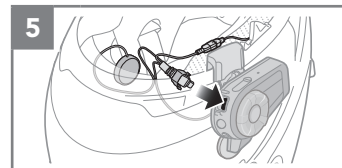
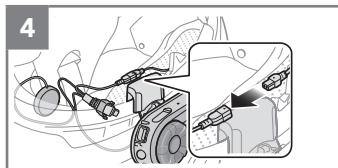
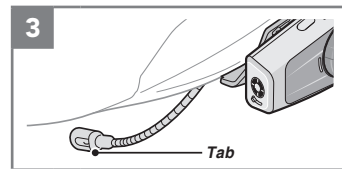
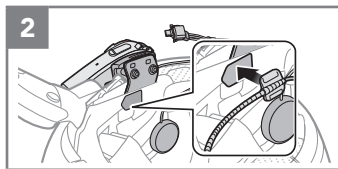
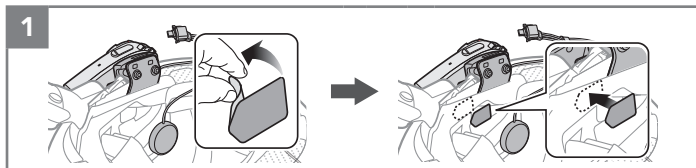



### 2.3.2 Using the Wired Microphone

If you have a full face helmet, you can use the wired microphone.

1. Attach the included hook and loop fastener for wired microphone to the inside of the helmet's chin guard.
2. Attach the wired microphone to the hook and loop fastener for wired microphone.
3. Align the arrows on the microphone and speaker cables and insert the microphone cable into the speaker cable.
4. Insert the speaker connector into the speaker port to connect it to the main unit.
5. Close the cover of the speaker cable to lock the cable to the port.

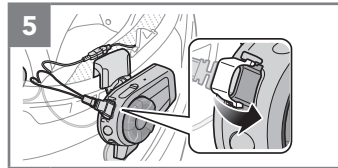
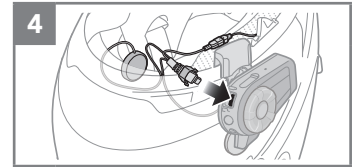
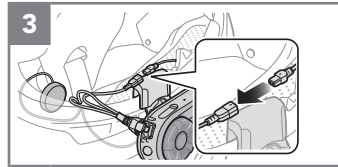
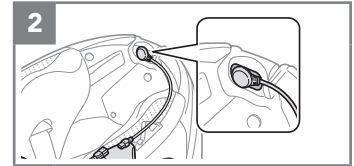
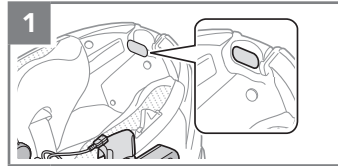

## 2.4 Adjusting the angle

You can adjust the angle for taking photos or recording videos.

You can rotate the horizontal angle by 30°. Rotate the lever below the lens to set the desired angle.

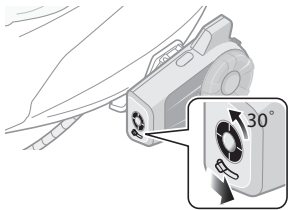

### 2.4.1 Using the Gear Clamp Unit

You can rotate the vertical angle by 360°. Loosen the wheel next to the main unit and rotate the main unit to set the desired angle. Tighten the wheel to lock it into position.

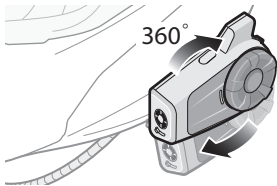

### 2.4.2 Using the Clamp Unit

You can change the vertical angle by 20° (Default), 8° or 32°. The vertical angle change shall be made before the clamp is mounted on the helmet.

- Loosen the two screws on the back plate of the clamp unit with the included allen wrench.

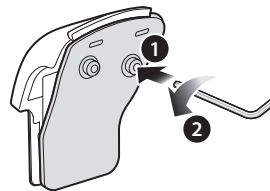

- Remove the angle plate and flip it up and down to make the angle display "8°" visible. The vertical angle is changed to 8°.
- Remove the angle plate and turn it backwards to make the angle display "32°" visible. The vertical angle is changed to 32°.

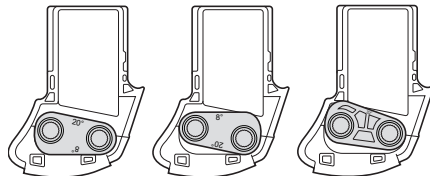

## 3 GETTING STARTED

### 3.1 Product Details

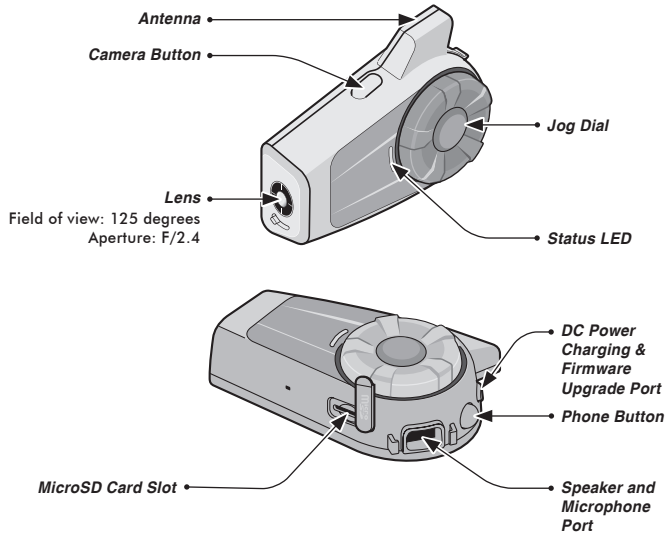

### 3.2 Powering On and Off

Press the Jog Dial and the Phone Button for 1 second to power on. Tap the Jog Dial and the Phone Button to power off.

### 3.3 Low Battery Warning

When the battery becomes low, you will hear a voice prompt, “**Camera off, battery low**”. The camera function will shut down soon, but other headset functions such as intercom will still be available for use. Then when the battery becomes very low, the blinking blue LED in stand-by mode turns to red and you will hear a voice prompt, “**Low battery**”. The headset will automatically shut down soon after.

### 3.4 Charging

The headset can be charged using many common methods via the supplied USB power & data cable. The LED turns red while the headset is charging and turns blue when it is fully charged. Depending upon the charging method, the headset will be fully charged in about 2.5 hours. The headset is compatible with 5 V input USB-charged devices only.

*Note:*

**Using When Plugged Into a Power Source (USB-charging adapter or Powerbank)**

*When you want to record long videos and time lapse events, connect the 10C EVO to a power source and then use it.*

- *If you connect the 10C EVO to the Powerbank while the camera is on, the 10C EVO will use the electricity stored in the Powerbank but the battery will not charge.*
- *If you connect the 10C EVO to the Powerbank while the camera is off, you can use the 10C EVO while it charges.*

### 3.5 Checking the Battery Level

#### 3.5.1 LED Indicator

When the headset is powering on, the red LED flashes rapidly indicating the battery level.

4 flashes = High, 70~100%

3 flashes = Medium, 30~70%

2 flashes = Low, 0~30%

#### 3.5.2 Voice Prompt Indicator

When you power on the headset, keep pressing the Jog Dial and the Phone Button simultaneously for about 5 seconds until you hear high tone triple beeps. Then you will hear a voice prompt indicating the battery level is high, medium, or low.

### 3.6 Volume Adjustment

You can raise or lower the volume by rotating the Jog Dial. Volume is set and maintained independently at different levels for each audio source, even when the headset is rebooted.

### 3.7 Sena Softwares

#### 3.7.1 Sena Device Manager

The **Sena Device Manager** allows you to upgrade the firmware and configure its settings directly from your PC or Apple computer. Download the **Sena Device Manager** from [sena.com](http://sena.com).

#### 3.7.2 Sena Utility App

By simply pairing your phone with your headset, you can use the **Sena Utility App** for quicker and easier set up and management.

- Download
  - Android: Google Play Store > **Sena Utility**
  - iOS: App Store > **Sena Utility**

### 3.7.3 Sena Camera App

You can see a live preview from the camera, manage recorded videos as well as configure the video settings using the built-in WiFi feature. When the camera and the **Sena Camera App** are connected, the camera is synchronized with the smartphone's date and time.

- Download
  - Android: Google Play Store > **Sena Camera**
  - iOS: App Store > **Sena Camera**

#### Note:

- When the camera is powered on, WiFi is automatically powered on and set to its default settings.
- WiFi will automatically be terminated if:
  - You do not use WiFi on the product for 3 minutes.
  - You do not use the Sena Camera App for 3 minutes.
- If you want to reactivate the WiFi after it is terminated, you will need to restart the camera.

## 4 CAMERA OPERATION

### 4.1 Camera On or Off

To turn on the camera, tap the Camera Button. The camera turns off automatically after 5 minutes of inactivity. To turn off the camera manually, tap the Camera Button and the Phone Button simultaneously.

### 4.2 Camera Modes

Mode	Application	Button
Video	Record video (normal recording, timelapse, loop recording)	Press and hold the Camera Button for 1 sec
Photo	Capture a single photo (Single Shot) or 8 photos (Burst Shot)	Tap the Camera Button

### 4.3 Video Recording

Press and hold the Camera Button for 1 second to start video recording. The green LED will flash and you will hear a voice prompt, **“Recording”**. Press and hold the Camera Button for 1 second to stop recording. You will hear a voice prompt, **“Recording stopped”**.

Below is a table of approximate video recording times to microSD card size in specific resolutions and frame rates.

	2160p/30fps	1440p/30fps	1080p/60fps	1080p/30fps
16GB	33 min	1 h 05 min	1 h 24 min	1 h 52 min
32GB	1 h 07 min	2 h 11 min	2 h 51 min	3 h 47 min
64GB	2 h 15 min	4 h 25 min	5 h 44 min	7 h 38 min
128GB	4 h 30 min	8 h 52 min	11 h 31 min	15 h 20 min

*Note:*

- *MicroSD cards up to 128GB are compatible. Using a U3 microSD card is suggested. Your microSD card needs to be formatted using the camera.*
- *The camera gives a warning and automatically stops recording when the microSD card is full or the battery becomes low.*
- *The maximum size per video is limited to 4GB. Therefore, when the video reaches the 4GB size limit during recording, it saves and creates a new video to continue recording.*

### 4.4 Video Mode (Default: Normal Recording Mode)

#### 4.4.1 Timelapse Video Mode

Timelapse video records series of photos at timed intervals and makes it into a video.

#### 4.4.2 Loop Recording Mode

Loop Recording mode continuously records videos to create footages of assigned length of time (3 minutes). If the memory reaches maximum, then the oldest footage will be deleted to store the most recent footage.

## 4.5 Photo Taking

### 4.5.1 Single Shot Mode

To take a single photo, set the photo mode setting in the camera configuration to be single shot mode. Tap the Camera Button to take a photo. The green LED will flash and you will hear a shutter sound.

### 4.5.2 Burst Shot Mode

Burst shot takes 8 photos. To take multiple photos, set the photo mode setting in the camera configuration to be burst shot mode. Tap the Camera Button to take multiple photos. The green LED will flash and you will hear shutter sounds.

#### Note:

- If you are recording in 2160p/30fps of video resolution, you cannot take a photo.
- The camera resolution is fixed to 12MP. However, when you take a photo during video recording, the photo resolution is fixed to 8.3MP.

## 4.6 Video Tagging

Video Tagging allows the camera to record video continuously, but save only the important events.

It creates video files of past, present, and future with each footage having an assigned length of time (3 minutes).

1. When you encounter an event that is worth saving, press and hold the Camera Button for 3 seconds. You will hear a voice prompt, **“Video tagging”**.
2. When Video Tagging is completed, you will hear a voice prompt, **“Tagging complete”**.

#### Note:

- Video Tagging can be operated only in the Loop Recording mode. In order for video files of past, present, and future to be saved, Video Tagging must be started at least 3 minutes after Loop Recording starts.
- Video Tagging recorded files are stored in **EVENT folder**.

#### 4.7 Format SD Card

1. Press and hold the Camera Button for 5 seconds until you hear the voice prompt, **“Format SD card”**.
2. Tap the Phone Button to confirm.

#### 4.8 WiFi Channel (Default: 5 GHz)

1. Press and hold the Camera Button for 10 seconds until you hear the voice prompt, **“WiFi channel”**.
2. Tap the Phone Button to confirm 2.4 GHz. You will hear triple beep.
3. Tap the Jog Dial to confirm 5 GHz. You will hear double beep.

*Note:*

***IF YOUR SMARTPHONE OR REGION DOES NOT SUPPORT 5 GHz,  
YOU MUST CHANGE THE WiFi CHANNEL TO 2.4 GHz.***

## 5 PAIRING THE HEADSET WITH BLUETOOTH DEVICES

You can pair the headset with Bluetooth mobile phones, Bluetooth stereo devices such as MP3, SR10, or GPS, and with other Sena Bluetooth headsets. The pairing operation is required only once for each Bluetooth device.

### 5.1 Mobile Phone Pairing - Mobile Phone, Bluetooth Stereo Device

1. Press and hold the Phone Button for 5 seconds and you will hear a voice prompt, **“Phone pairing”**.
2. Search for Bluetooth devices on your mobile phone. Select the Sena 10C EVO in the list of the devices detected on the mobile phone.
3. If your mobile phone asks for a PIN, enter 0000.



## 5.2 Second Mobile Phone Pairing - Second Mobile Phone, GPS, and SR10

1. Press and hold the Jog Dial for 5 seconds and you will hear a voice prompt, **“Intercom pairing”**.
2. Within 2 seconds, tap the Phone Button again and you will hear a voice prompt, **“Second mobile phone pairing”**.
3. Search for Bluetooth devices on your mobile phone. Select the Sena 10C EVO in the list of the devices detected on the mobile phone.
4. If your mobile phone asks for a PIN, enter 0000.

## 5.3 Advanced Selective Pairing: A2DP Stereo or Handsfree

Phone Pairing allows the headset to establish two Bluetooth profiles: Hands-Free or A2DP Stereo. Advanced Selective Pairing allows the headset to separate the profiles to enable connection with two devices.

### 5.3.1 A2DP Stereo Music Only

1. Press the Phone Button for 5 seconds until the LED flashes red and blue alternately and you hear multiple beeps.
2. Within 2 seconds, tap the Jog Dial again and you will hear a voice prompt, **“Media selective pairing”**.
3. Search for Bluetooth devices on your smartphone. Select the Sena 10C EVO in the list of devices detected on your phone.
4. If your mobile phone asks for a PIN, enter 0000.

### 5.3.2 HFP for Phone Call Only

1. Press the Phone Button for 5 seconds until the LED flashes red and blue alternately and you hear multiple beeps.
2. Within 2 seconds, tap the Phone Button again and you will hear a voice prompt, **“Phone selective pairing”**.
3. Search for Bluetooth devices on your smartphone. Select the Sena 10C EVO in the list of devices detected on your phone.
4. If your mobile phone asks for a PIN, enter 0000.

## 5.4 Intercom Pairing

### 5.4.1 Pairing with Other Headsets for Intercom Conversation

The headset can be paired with up to three other headsets for Bluetooth intercom conversation.

1. Press and hold the Jog Dial of the **headset A and B** for 5 seconds.
2. Simply tap the Jog Dial of any one of the two **headsets A and B**, and wait until the LEDs of both headsets turn to blue and intercom connection is automatically established.
3. You can make other pairings between **headsets A and C**, and between **headsets A and D** by following the same procedure as above.

4. The intercom pairing queue is '**Last-Come, First-Served**'. If a headset has multiple paired headsets for intercom conversations, the last paired headset is set as **first intercom friend**. The previous intercom friend becomes **second intercom friend**, and **third intercom friend**.

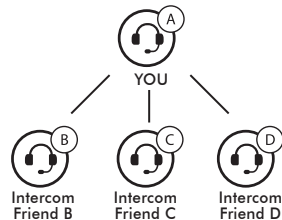

## 6 MOBILE PHONE, GPS

### 6.1 Mobile Phone Call Making and Answering

1. To answer a call, tap the Phone Button or the Jog Dial to answer the call.
2. You can also answer the incoming call by loudly speaking any word of your choice if VOX Phone is enabled, unless you are connected to intercom.
3. To end a call, tap the Phone Button or press the Jog Dial for 2 seconds until you hear a beep.
4. To reject a call, press the Jog Dial for 2 seconds until you hear a beep while the phone is ringing.
5. To transfer a call between the mobile phone and the headset during the phone conversation, press the Phone Button for 2 seconds until you hear a beep.
6. To make a call with voice dialer, Tap the Phone Button in stand-by mode to activate the voice dialer of your mobile phone.

### 6.2 Speed Dialing

1. Double tap the Phone Button and you will hear a voice prompt, “**Speed dial**”.
2. Rotate the Jog Dial clockwise or counter clockwise to navigate between the menus. You will hear prompts for each menu item.
3. Tap the Phone Button to select a voice menu among the followings:  

<b>(1) Last number redial</b>	<b>(4) Speed dial 3</b>
<b>(2) Speed dial 1</b>	<b>(5) Cancel</b>
<b>(3) Speed dial 2</b>	
4. After selecting the last number redial menu, “**Last number redial**”. Then, to redial the last phone call number, tap the Phone Button.
5. To call one of the speed dials, rotate the Jog Dial clockwise or counter clockwise to navigate between the menus until you hear a voice prompt, “**Speed dial (#)**”. Then, tap the Phone Button.
6. If you want to exit the speed dial immediately, rotate the Jog Dial until you hear a voice prompt, “**Cancel**”, and tap the Phone Button or the Jog Dial.

## 6.3 GPS Navigation

### 6.3.1 GPS Pairing

1. Press and hold the Jog Dial for 5 seconds until you will hear a voice prompt saying **“Intercom pairing”**.
2. Within 2 seconds, double tap the Phone Button and you will hear the voice prompt saying **“GPS pairing”**.
3. Search for Bluetooth devices on the GPS navigation. Select the Sena 10C EVO in the list of the devices detected on the GPS.
4. Enter 0000 for the PIN.

*Note:*

*When Audio Multitasking is enabled, if you pair your GPS device via GPS Pairing, its instructions will not interrupt your intercom conversations, but will overlay with them.*

## 7 STEREO MUSIC

### 7.1 Bluetooth Stereo Music

1. To play or pause music, press and hold the Jog Dial for 1 second until you hear a double beep.
2. To adjust the volume, rotate the Jog Dial.
3. To track forward or track back, rotate while pressing the Jog Dial clockwise or counter clockwise.

## 7.2 Music Sharing

You can start sharing music with an intercom friend using Bluetooth stereo music during a two-way intercom conversation. When you terminate music sharing, you can go back to the intercom conversation. To start or terminate sharing music, press and hold the Jog Dial for 1 second during an intercom conversation until you hear a double beep.

### Note:

1. Both you and your intercom friend can remotely control music playback such as track forward and track back.
2. Music sharing will be paused when you are using your mobile phone or listening to GPS instructions.
3. When Audio Multitasking is enabled, if an intercom call is made when you are listening to music, music sharing will not work.

# 8 INTERCOM

## 8.1 Two-way Intercom

### 8.1.1 Starting Two-way Intercom

You can start an intercom conversation with one of any intercom friends by tapping the Jog Dial: single tap to intercom with the **first intercom friend**, double tap to intercom with the **second intercom friend**, and triple tap to intercom with the **third intercom friend**.

### 8.1.2 Ending Two-way Intercom

You can single tap to end intercom with the **first intercom friend**, double tap to end intercom with the **second intercom friend**, and triple tap to end intercom with the **third intercom friend**.

## 8.2 Multi-Way Intercom

Multi-Way Intercom enables conference-call-style conversations with up to three intercom friends at the same time. While multi-way intercom is in progress, mobile phone connection is temporarily disconnected. However, as soon as multi-way intercom terminates, the mobile phone connection will be reestablished.

### 8.2.1 Starting Three-way Intercom

1. You (A) need to be paired with two other friends (B & C) for three way conference intercom.
2. Start an intercom conversation with one of the two friends in your intercom group.
3. You (A) can call the second intercom friend (C) by double tapping the Jog Dial, or the second intercom friend (C) may join the intercom by making an intercom call to you (A).

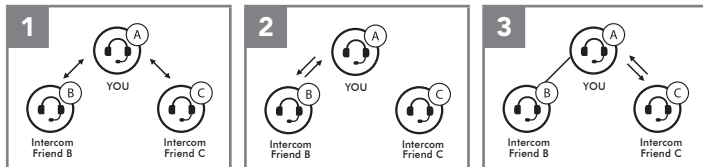

### 8.2.2 Starting Four-way Intercom

With three intercom friends connected, a new participant (D) can make it a four-way intercom conference by making an intercom call to either (B) or (C).

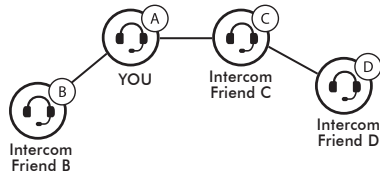

### 8.2.3 Ending Multi-Way Intercom

You can completely terminate the conference intercom or just disconnect an intercom connection with one of your active intercom friends.

1. Press and hold the Jog Dial for 3 seconds until you hear a beep to terminate all intercom connections.
2. Tap the Jog Dial to disconnect from your first intercom friend. Double tap the Jog Dial to disconnect from your second intercom friend.

*Note:*

*Multiple headsets are connected during multi-way intercom. With various signals interfering each other, the intercom distance of multi-way intercom is relatively shorter than that of two-way intercom.*

## 9 THREE-WAY CONFERENCE PHONE CALL WITH INTERCOM PARTICIPANT

You can have a three-way conference phone call by adding an intercom friend to the mobile phone conversation.

1. During a mobile phone call, tap the Jog Dial to invite one of your intercom friends to the conversation.
2. To disconnect the intercom during a conference phone call, tap the Jog Dial.
3. To disconnect the mobile phone call during a conference phone call, press the Jog Dial for 2 seconds or tap the Phone Button.

## 10 GROUP INTERCOM

Group Intercom allows you to instantly create a multi-way conference intercom with three other most recently paired headsets.

1. Go through intercom pairing with up to three headsets you want to have Group Intercom with.
2. Press the Jog Dial for 3 seconds to begin Group Intercom. The LED will flash green.
3. To terminate Group Intercom, press the Jog Dial for 3 seconds during Group Intercom.

## 11 UNIVERSAL INTERCOM

Universal Intercom allows you to have intercom conversations with users of non-Sena Bluetooth headsets. Non-Sena Bluetooth headsets can be connected to the Sena Bluetooth headset if they support the Bluetooth Hands-Free Profile (HFP). You can pair the headset with only one non-Sena headset at a time. The intercom distance depends on the performance of the Bluetooth headset to which it's connected.

When a non-Sena Bluetooth headset is paired with the headset, if another Bluetooth device is paired via Second Mobile Phone Pairing, it will be disconnected.

1. Press and hold the Jog Dial for 10 seconds to enter the headset configuration menu. Rotate the Jog Dial until you hear a voice prompt, **“Universal intercom pairing”**. Tap the Phone Button to enter into Universal Intercom Pairing mode and you will hear multiple beeps.
2. Put the non-Sena Bluetooth headset in Pairing Mode. The headset will automatically pair with a non-Sena Bluetooth headset.



3. You can have a two-way intercom or multi-way intercom communication with up to three intercom friends using non-Sena headset.



**Three-way Universal Intercom**

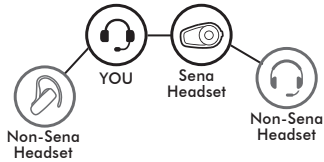

**Four-way Universal Intercom**

*Note:*

*Some non-Sena headsets may not support multi-way universal intercom.*

## 12 FUNCTION PRIORITY

The headset operates in the following order of priority:

- (highest)** Mobile phone
- Intercom
- Music sharing by Bluetooth stereo music
- (lowest)** Bluetooth stereo music

A lower priority function is always interrupted by a higher priority function.

*Note:*

*If you select music as the audio source priority, the order of priority will change as below:*

- (highest)** Mobile phone
- Bluetooth stereo music
- Intercom
- (lowest)** Music sharing by Bluetooth stereo music

## 13 CONFIGURATION SETTING

### 13.1 Headset Configuration Setting

1. To enter into configuration menu, press and hold the Jog Dial for 10 seconds until you will hear a voice prompt, “**Configuration menu**”.
2. Rotate the Jog Dial clockwise or counter clockwise to navigate between the menus. You will hear voice prompts for each menu item.
3. You can execute the command by tapping the Phone Button.

Configuration Menu	Tap Phone Button
Delete All Pairings	Execute
Remote Control Pairing	Execute
Universal Intercom Pairing	Execute
Exit Configuration	Execute

### 13.1.1 Remote Control Pairing

You can remotely control the headset using Sena Remote Control devices (sold separately).

1. Turn on the headset and the Remote Control device.
2. Execute Remote Control Pairing.
3. Enter pairing mode in the Remote Control device. The headset will automatically connect with the Remote Control device in pairing mode.

## 13.2 Software Configuration Setting

You can change the settings of the headset through the Sena Device Manager or the Sena Utility App.

### 13.2.1 Speed Dial

Assign phone numbers for speed dialing to make a phone call quickly.

### 13.2.2 Audio Source Priority (Default: Intercom)

Audio Source Priority allows you to select the priority between the intercom and music (which includes GPS app instructions and message notifications) from a smartphone. If the intercom is selected as the audio source priority, your music will be interrupted during an intercom conversation. If music is selected as the audio source priority, intercom conversations will be interrupted while your music is heard.

*Note:*

*Audio Source Priority is active only when Audio Multitasking is disabled.*

### 13.2.3 Audio Equalizer (Default: Off)

You can use the **Audio Equalizer** to increase/decrease the decibel level of different frequency ranges of audio.

**Balance** will adjust all of the frequency ranges to be the same volume level (0 dB). **Bass Boost** will increase the bass range of audio (20 Hz - 250 Hz). **Mid Boost** will increase the mid range of audio (250 Hz - 4 kHz).

**Treble Boost** will increase the high range of audio (4 kHz - 20 kHz).

### 13.2.4 VOX Phone (Default: Enable)

If this feature is enabled, you can answer incoming calls by voice. When you hear a ringtone for an incoming call, you can answer the phone by saying a word such as **“Hello”** loudly or by blowing air into the microphone. VOX phone is temporarily disabled if you are connected to intercom. If this feature is disabled, you have to tap the Phone Button to answer an incoming call.

### 13.2.5 VOX Intercom (Default: Disable)

If this feature is enabled, you can initiate an intercom conversation with the last connected intercom friend by voice. When you want to start intercom, say a word such as **“Hello”** loudly or blow air into the microphone. If you start an intercom conversation by voice, the intercom terminates automatically when you and your intercom friend remain silent for 20 seconds. However, if you manually start an intercom conversation by tapping the Jog Dial, you have to terminate the intercom conversation manually. However, if you start intercom by voice and end it manually by tapping the Jog Dial, you will not be able to start intercom by voice temporarily. In this case, you have to tap the Jog Dial to restart the intercom. This is to prevent repeated unintentional intercom connections by strong wind noise. After rebooting the headset, you can start intercom by voice again.

### 13.2.6 HD Voice (Default: Disable)

HD Voice allows you to communicate in high-definition during phone calls. This feature increases the quality so that the audio will be crisp and clear during phone call conversations.

If this feature is enabled, incoming phone calls will interrupt intercom conversations and audio from the SR10 will not be heard during intercom conversations. Three-Way Conference Phone Call with Intercom Participant will not be available if HD Voice is enabled.

*Note:*

1. Refer to the manufacturer of your Bluetooth device that will be connected to the headset to see if it supports HD Voice.
2. HD Voice is active only when Audio Multitasking is disabled.

### 13.2.7 HD Intercom (Default: Enable)

HD Intercom enhances the two-way intercom audio from normal quality to HD quality. HD Intercom will become temporarily disabled when you enter into a multi-way intercom. If this feature is disabled, the two-way intercom audio will change to normal quality.

*Note:*

1. The intercom distance of HD Intercom is relatively shorter than that of normal intercom.
2. HD intercom is active only when Audio Multitasking is disabled.

### 13.2.8 Voice Prompts (Default: Enable)

You can disable voice prompts by software configuration setting, but the following voice prompts are always on.

- Headset configuration setting menu, battery level indicator, speed dial

### 13.2.9 Sidetone (Default: Disable)

Sidetone is audible feedback of your own voice. It helps you to naturally speak at the correct level according to varying helmet noise conditions. If this feature is enabled, you can hear what you are speaking during an intercom conversation or a phone call.

### 13.2.10 Advanced Noise Control™ (Default: Enable)

When Advanced Noise Control is enabled, the background noise is reduced during an intercom conversation. When it is disabled, the background noise is mixed with your voice during intercom.

### 13.2.11 Audio Multitasking™ (Default: Disable)

Audio Multitasking allows you to hear the audio from two features simultaneously. When Audio Multitasking is enabled, phone calls, GPS instructions, and intercom conversations can be overlaid with audio from the music or GPS app instructions from a smartphone in the background with reduced volume. Increasing or decreasing the volume of the audio in the foreground will also increase or decrease the volume of the overlaid audio in the background. The volume of the foreground audio can be adjusted using the headset. How much background audio that is heard can be adjusted using the Sena Utility App. HD Intercom, HD Voice, and Audio Source Priority become disabled temporarily when Audio Multitasking is enabled.

Model	Foreground*			Background**
	Phone	GPS	Intercom	Music or Smart Navi
10C EVO	○ <sup>A</sup>	○ <sup>A</sup>		
		○	○	
			○ <sup>B</sup>	○ <sup>B</sup>
		○		○

**Foreground and Background Combination Table**

\* Two audio sources in the foreground can be heard simultaneously with the same volume level.

\*\* Only one background source can be heard at a time while listening to an audio source in the foreground.

A. GPS instructions can be heard during phone calls and the volume level of both audio sources can be adjusted using the headset.

B. GPS app directions will be heard in the background during intercom conversations.

*Note:*

- 1. Audio Multitasking will be activated during two-way intercom conversations with a headset that also supports this feature.*
- 2. When Audio Multitasking is disabled, the background audio source will return to its independent volume level.*
- 3. For Audio Multitasking to work properly, you need to power the headset off and on. Please restart the headset.*
- 4. Some GPS devices may not support this feature.*

**13.2.12 Background Volume (Default: Level 5)**

The Background Volume can be adjustable only when the Audio Multitasking turns on. Level 9 is the highest volume and 0 is the lowest.

**13.3 Camera Configuration Setting**

You can change the settings of the camera through the Sena Camera App.

**13.3.1 Photo Mode (Default: Single Shot Mode)**

You can select the photo mode to be either single shot or burst shot. Single shot takes a single photo while burst shot takes 8 photos.

**13.3.2 Video Mode (Default: Normal Recording Mode)**

You can select the video mode to be normal recording mode, timelapse mode, or loop recording mode. Timelapse mode records series of photos at timed intervals and makes it into a video. Loop recording mode constantly records videos at timed intervals, replacing old video files when memory is full.

### 13.3.3 Video Resolution (Default: 2160P/30fps)

You can select the video resolution to be 2160P/30fps, 1440P/30fps, 1080P/60fps, or 1080P/30fps.

### 13.3.4 Timelapse Interval (Default: 1 sec)

You can select the timelapse interval to be 1 second, 2 seconds, 5 seconds or 10 seconds.

### 13.3.5 Video Microphone Gain (Default: Medium)

You can select the microphone gain for video recording to be low, medium, or high.

### 13.3.6 Date Caption (Default: Off)

You can record or hide date caption during video recording. If you select on, the date caption will be displayed on top of your recorded video. If you select off, the date caption will not be shown on your recorded video.

### 13.3.7 Smart Audio Mix™ (Always On)

Smart Audio Mix allows you to record everything you hear through your speakers as well as your voice during video recording. The function that governs **Smart Audio Mix** is called **Speaker Sound Recording**.

*Note:*

*A phone conversation is not recorded.*

### 13.3.8 Auto Camera Sleep (Default: On)

You can set the camera to automatically power off after 5 minutes of inactivity. This feature does not work while charging the camera.

### 13.3.9 Format SD Card

SD card format will remove all files from a microSD card. When you use a new card for the first time, always format it before using the camera.

## 14 FIRMWARE UPGRADE

The headset supports firmware upgrades. You can update the firmware using the Sena Device Manager. Please visit Sena website at [www.sena.com](http://www.sena.com) to check the latest software downloads.

## 15 TROUBLESHOOTING

### 15.1 Fault Reset

When the headset is not working properly, you can easily reset the unit:

1. Locate the pinhole reset button at the back of the headset main unit.
2. Gently insert a paperclip into the hole and tap the Fault Reset Button with light pressure.
3. The headset will shut down.

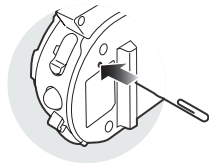

*Note:*

*Fault Reset will not restore the headset to factory default settings.*



## 15.2 Factory Reset

1. To restore the headset to factory default settings, press and hold the Phone Button for 10 seconds until the LED shows solid red.
2. Press the Jog Dial to confirm reset. The headset will be restored to factory setting and switched off automatically.

