

SHOW CHROME®

Copyright© 2023 by Big Bike Parts, Inc. No part of this instruction sheet may be reproduced without the written permission of Big Bike Parts, Inc.

INSTALLATION INSTRUCTIONS

PART NO. 52-972/ 52-972BK

DESCRIPTION: MARVEL LOWER RUN & BRAKE LIGHT

ESTIMATED INSTALLATION TIME: 45 TO 60 MIN

FITMENT: HONDA GOLD WING 2018-NEWER

TOOLS NEEDED:	PEN/ PENCIL	6MM ALLEN	5MM ALLEN	RUBBING ALCOHOL	CLEAN RAG	DRILL	5/16" DRILL BIT
FISH TAPE/ WIRE	MASKING TAPE						
INCLUDED:	FENDER LIGHT ASSEMBLY (1X)	MALE SPADE CONNECTOR (3X)	T-TAP CONNECTOR (3X)	100MM WIRE TIE (8X)			
EXTRA ITEMS (NOT NEEDED):	NA						

PLEASE READ THROUGH AND UNDERSTAND THESE INSTRUCTIONS BEFORE BEGINNING. *USE REMOVABLE THREAD LOCK ON ALL FASTENERS* USE OF SHOW CHROME ISOLATOR FUSE BLOCK IS RECOMMENDED FOR INSTALL. TEST LIGHT FOR FUNCTIONALITY

INSTALLATION:

- Open both saddlebags and remove both side panels. Pull on the front of each panel to remove them. See **FIG. 1**.
- Using a 6MM Allen wrench, remove the two Allen bolts holding the seat on and place to the side to be reinstalled later. There is one on each side toward the front of the seat. See **FIG. 2**.
- Unplug the connector for the seat on the right side shown in **FIG. 3**.
- Lift the front of the seat up and pull it forward to remove it. Place the seat with the bottom up on a clean surface.
- Remove the two Allen screws holding the rear fender (**FIG. 4**), and set aside.
- Pull straight back on the bottom of the fender to release the rubber grommet. Then pull straight back on the top to release the rear fender.
- Unplug the license plate light connector (**FIG. 5**).
- Use tape to cover the fender near the center of the lower portion shown in **FIG. 6**.
- Using **FIG. 6** to locate the two points, line up a ruler between the points and mark the center on the tape.
- Extend the center mark down to the bottom of the outer face of the fender in **FIG. 7** and make a small horizontal mark at that point. Measure 1 7/16" up from the horizontal mark on the bottom outer face and mark the horizontal. Use 5/16" Brad Point drill bit to drill hole at the intersection as shown.
- Route a fish tape or wire down through opening under the seat referenced in **FIG. 8**.
- Note the location in **FIG. 9** where the fish tape or wire comes down. Route the cable through the fender making sure to go from the outside to the inside. DO NOT REMOVE backing from double sided tape yet.
- Pull wire up under seat location to where Show Chrome Isolator Fuse Block is located (or route to your desired power location). Go back to the rear of the bike and push down on plastic flap and slide wire over into cut out that is shown in **FIG. 9**.
- Using **FIG. 10** as a reference, route the light cable across the plastic ledge and down through the notch. Then bring the wire down and run it over the bar to the right side of the grommet that holds the rear fender.
- Reinstall rear fender by doing steps 5-7 in reverse order.
- Clean the lower portion of the lower rear fender where light will sit with rubbing alcohol and a clean rag and allow to dry.
- Remove backer from tape and align light to fender. Use care to make sure that the cable is pulled tight through the fender. Firmly press and hold light in place to allow tape to set to the fender.
- Pull slack wire up into the under seat area. **Wire ties may be used** to hold the wire to the rear bar that the grommet for the fender is in or along other wires running under the seat.
- Using **FIG. 11** connect each wire to an electronic fuse block or desired locations for power, brake, and ground.
- Blue wire for running, black wire for ground, red wire for brake.
- Remove the protective film and test all functions of the light.

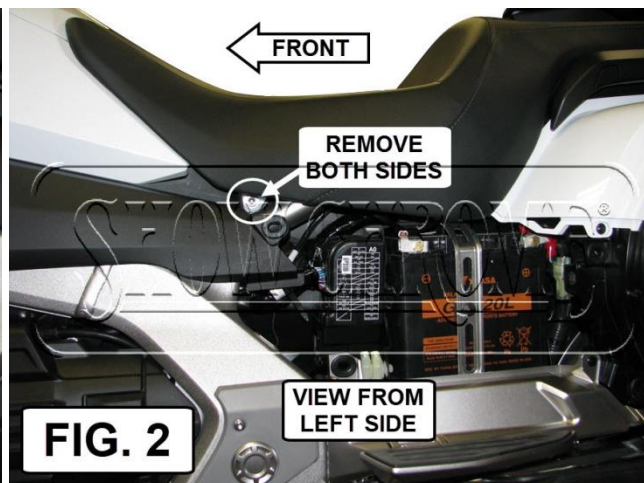
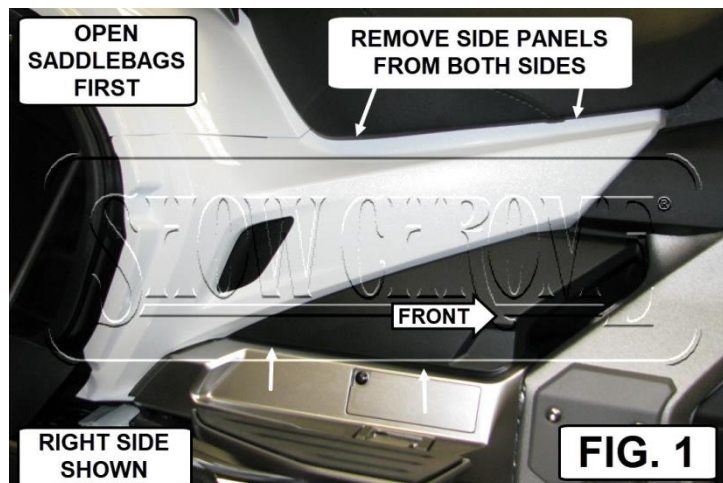

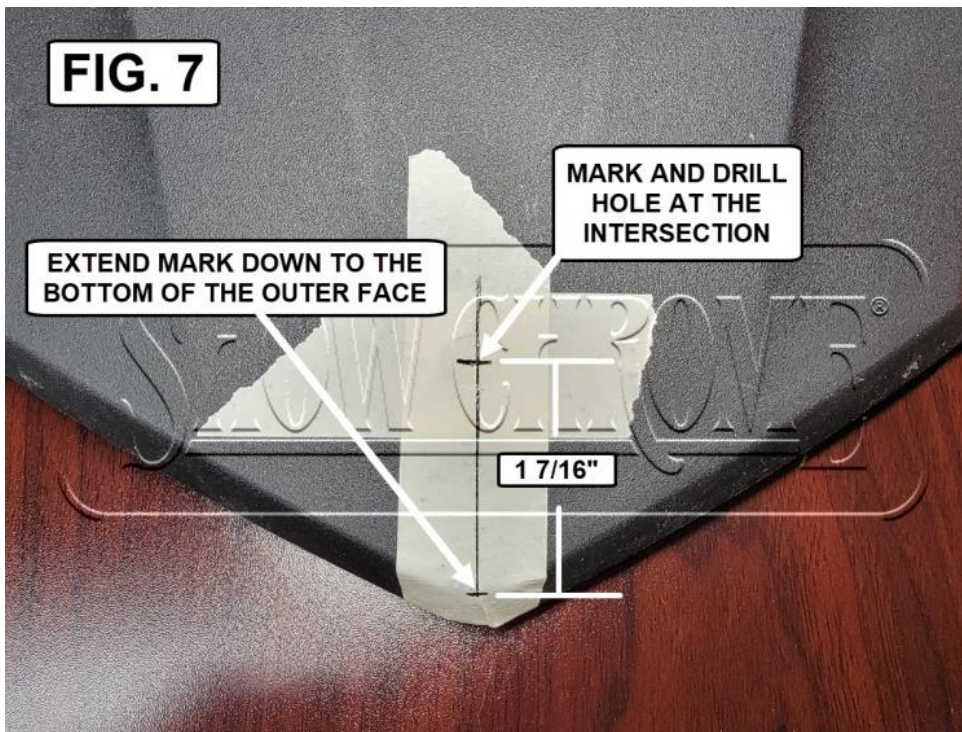
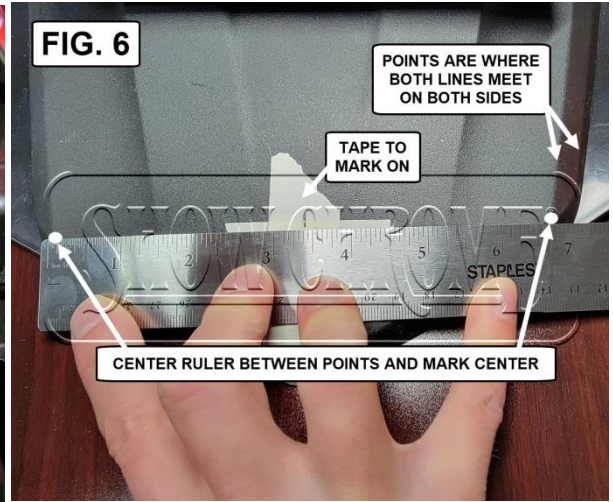
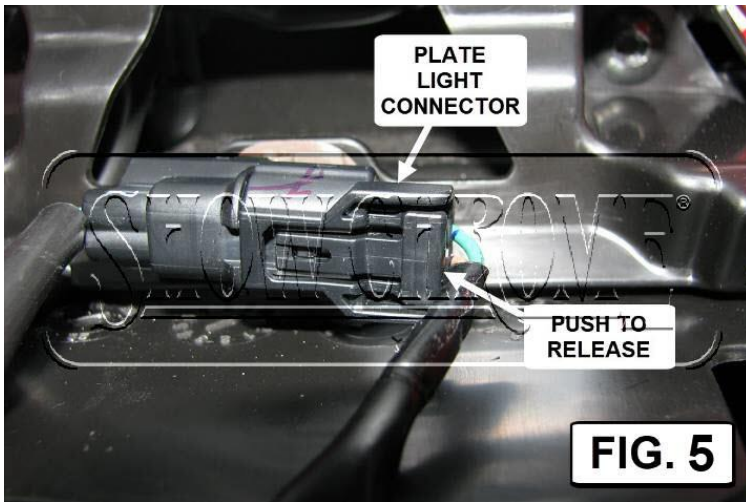
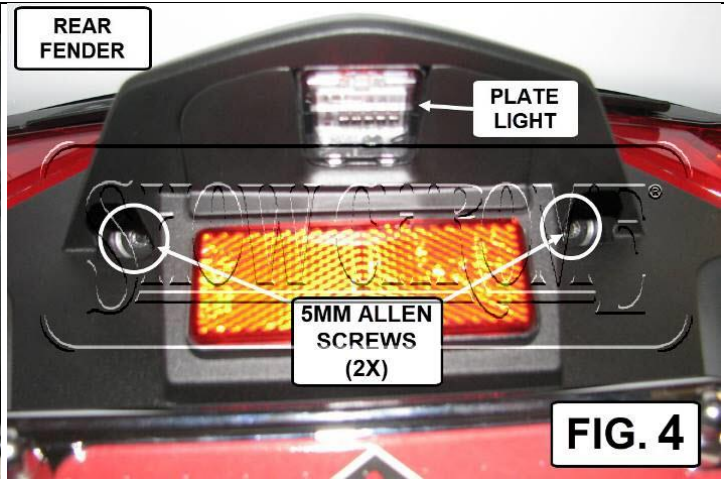
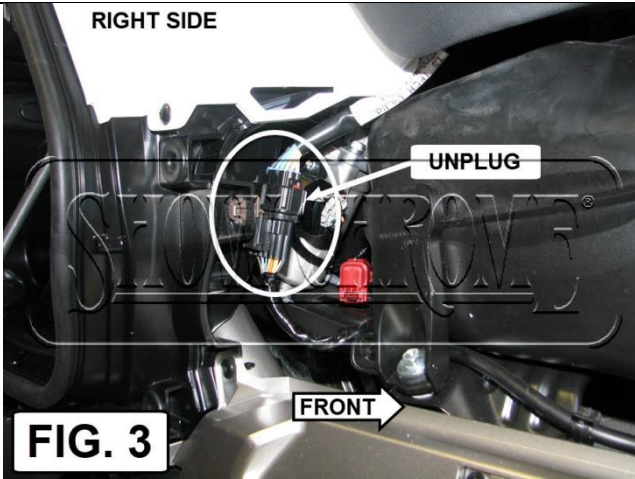

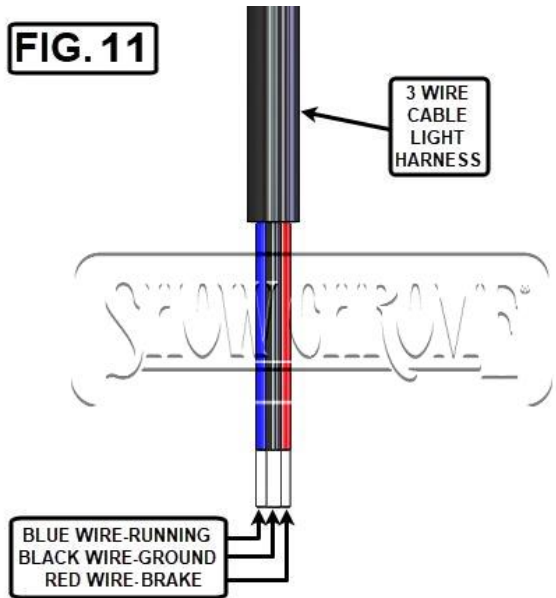
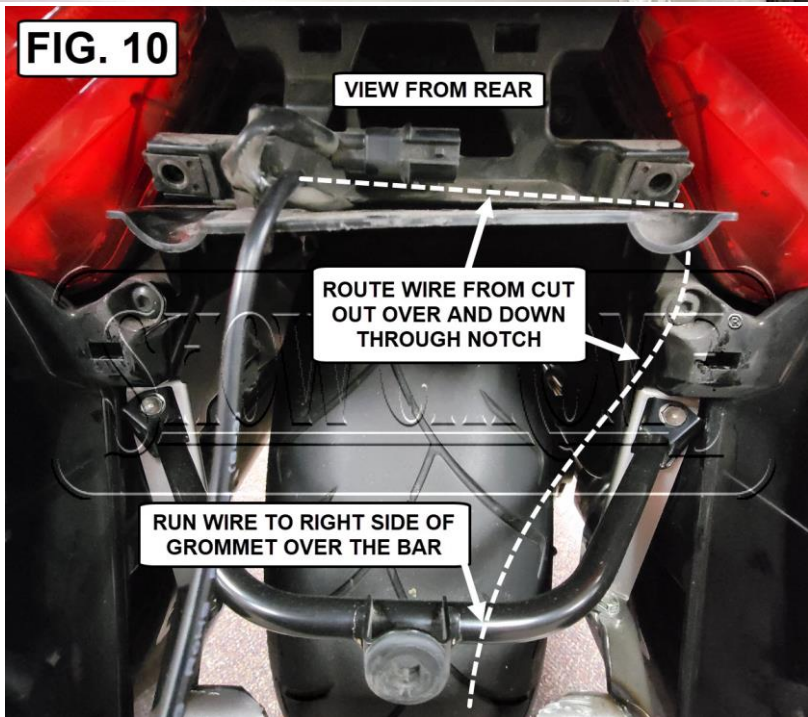
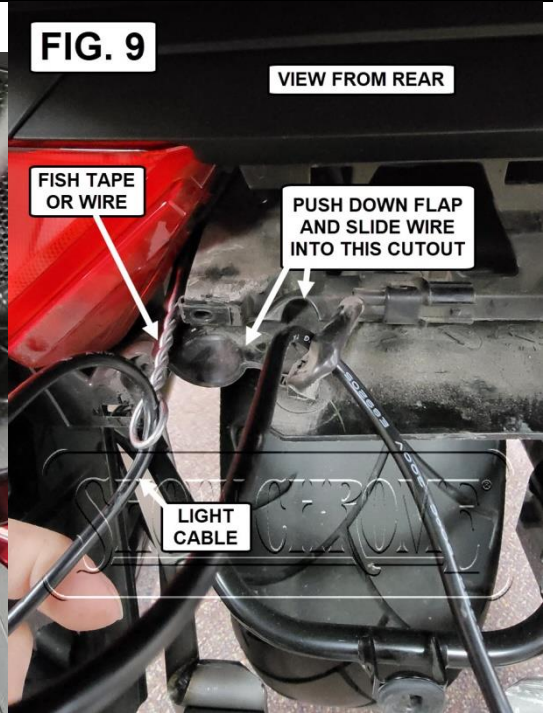
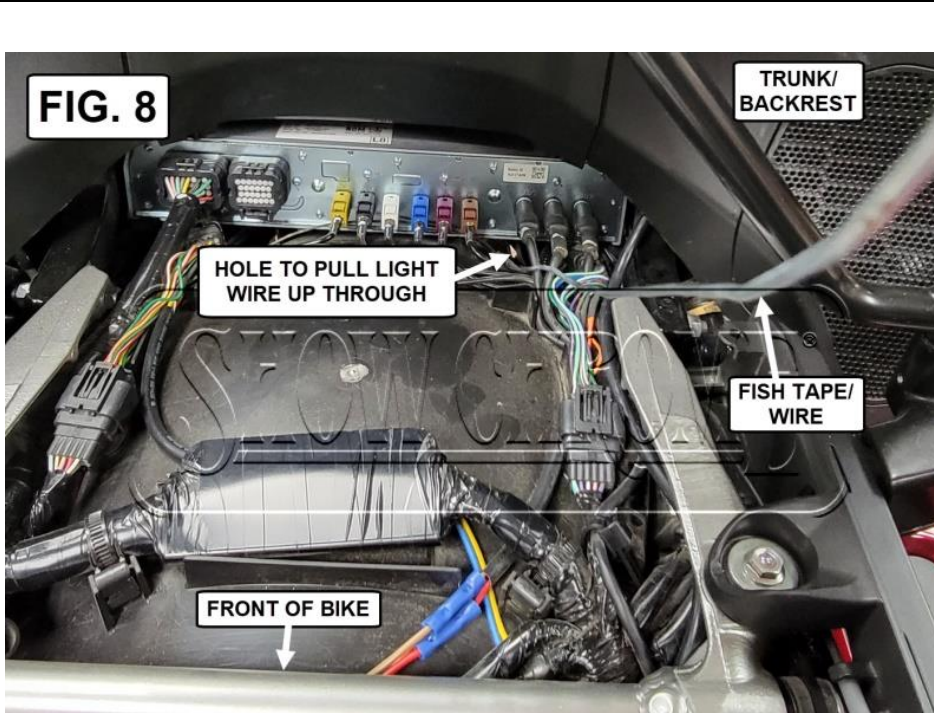

NOTICE
 ADDING MULTIPLE ACCESSORIES TO A CIRCUIT MAY CAUSE ISSUES WITH SOME ACCESSORIES

NOTICE
 IGNORING THE CONTENTS OF THESE INSTRUCTIONS MAY AFFECT THE PRODUCT PERFORMANCE AND FUNCTIONALITY. NOT FOLLOWING THESE INSTRUCTION MAY CAUSE DAMAGE TO THE PRODUCT OR THE VEHICLE TO WHICH IT IS BEING ATTACHED.

NOTICE
 BIG BIKE PARTS RECOMMENDS INSTALLING AN ISOLATION FUSE BLOCK (PART NUMBER 52-942) BEFORE CONNECTING ANY ADDED ELECTRICAL ACCESSORIES TO THE BIKE