

Congratulations, you have purchased the finest exhaust system available for your motorcycle. Your Vance & Hines exhaust is designed and crafted for performance, quality, and style. Please follow the instructions below, check exhaust system for missing or damaged parts and if you need any assistance please contact our technical support line (562) 921-7461.

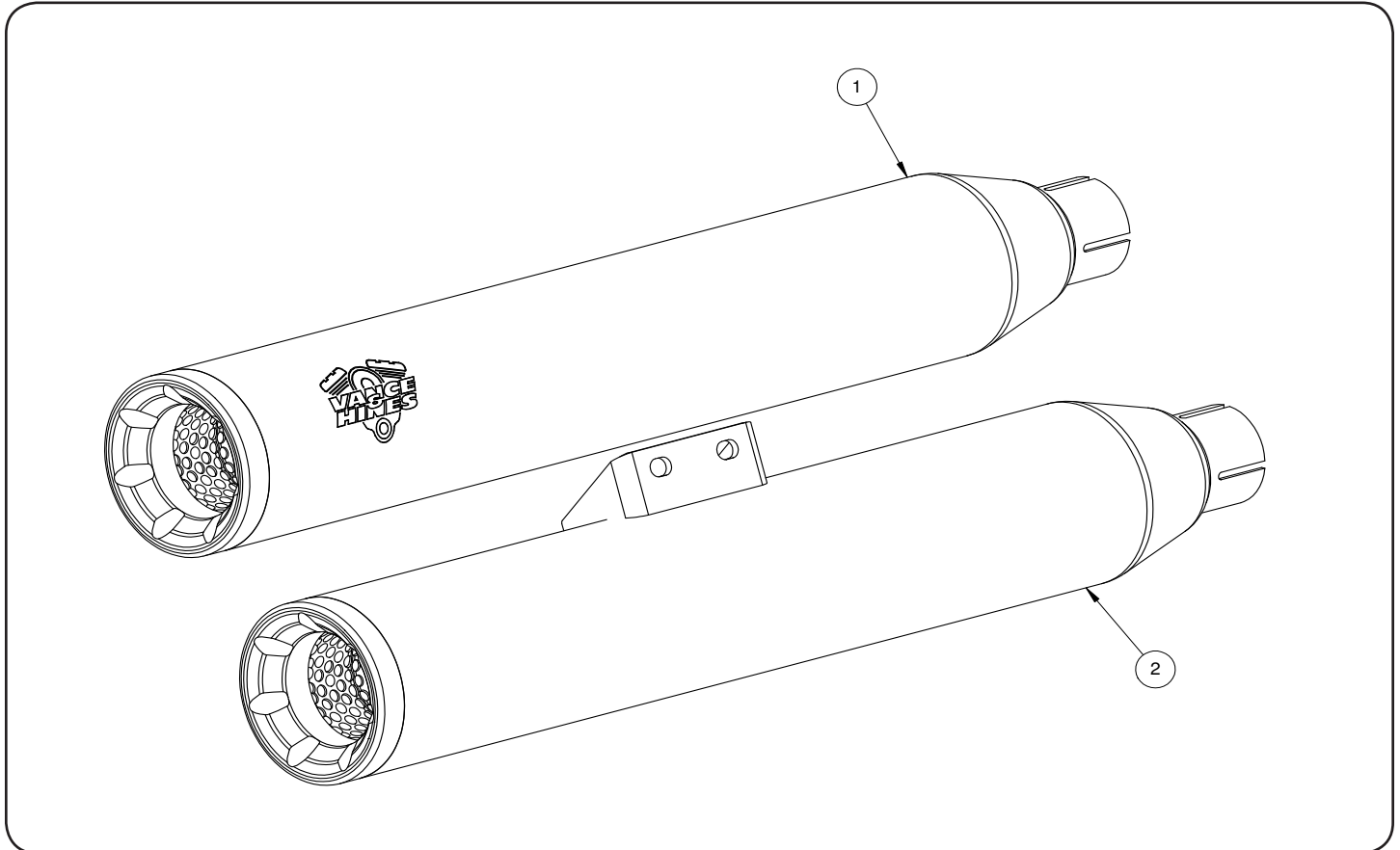

PARTS LIST

	Part No.	Description	Qty.
1	D673RC/ D677RC/D675RP-S	Rear Muffler Casing	1
2	D672RC/D676RC/D674RP	Front Muffler Casing	1
3	A231HW	1.56'' - 1.70'' T-Bolt clamp	2
4	A155HP	Bracket Cover (Chrome ONLY)	1
5	A601HW	1/4-20x1 Button Head Bolt	4

HARDWARE

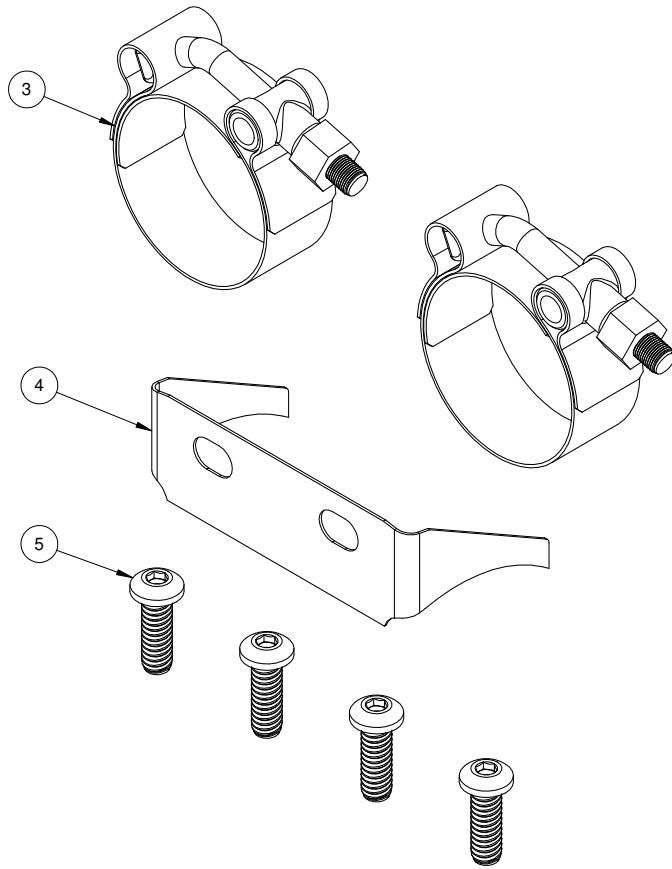

TOOLS REQUIRED

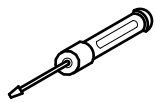

Flat Blade Screwdriver

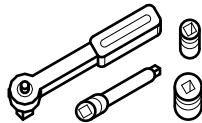

3/8" Ratchet w/ 4" extension & 1/2", 9/16" Socket

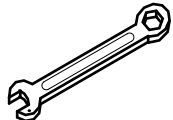

Combination Wrench: 9/16", 11mm

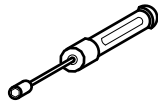

5/16" Nut Driver

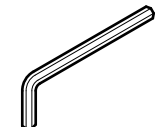

Allen Wrench: 5/32", 3/16"

STOCK EXHAUST SYSTEM REMOVAL

1. OPTIONAL: Head pipes may need to be loosened from cylinder head slightly in order for proper fitment during reinstallation.
2. Loosen the existing muffler clamps on the front of your stock mufflers.
3. Remove the four 1/4-20 bolts securing the mufflers to the stock muffler bracket. This hardware will not be re-used.
4. Remove the stock mufflers by sliding them back off the stock headers. **NOTE:** Penetrating oil may be required to loosen muffler from head pipes.

VANCE & HINES EXHAUST INSTALLATION

1. Install the T-bolt clamps (3) over the front and rear muffler inlets so that the bolt is facing up for the rear muffler and the bolt is down for the front muffler. **NOTE:** Leave loose at this time. **NOTE:** The rear muffler is dented for clearance purposes.
2. Slide mufflers onto the head pipes. The muffler with the Vance and Hines logo goes on the rear cylinder head pipe (top).
3. Mount the bracket cover (4) on the lower muffler bracket. **NOTE:** This bracket cover is not included with the black system, 46712. Attach the muffler bodies to the mounting bracket using four 1/4-20 x 1 button head bolts (5). **NOTE:** Leave them loose at this time.
4. Align mufflers and tighten hardware, beginning with the 1/4-20 x 1 button head bolts on the mounting brackets.
5. Tighten the T-bolt clamps. **NOTE:** You may want to use an assistant at this time to visually check alignment while you tighten the hardware. Pay special attention to making sure the muffler does not droop when viewed from the back of the motorcycle.
6. Retighten header pipe if required.
7. After installation and before starting motorcycle, completely clean pipes and mufflers with warm, soapy water and a clean, soft cloth that will not leave a residue. **NOTE:** Any residue, oil, or fingerprints will stain the chrome when the metal heats up.
8. Be sure to tighten all hardware before starting your motorcycle.
9. **IMPORTANT: AFTER TEST RIDE LET PIPES COOL DOWN AND RE-TORQUE T-BOLT CLAMPS.**

EXHAUST CARE (CHROME / SATIN CHROME)

- 1.** When installing a new set of chrome pipes, make sure your hands are clean and free of oil. After installation, thoroughly clean pipes with a soft cloth and cleaning solvent that will leave no residue (chrome wax/polish, glass cleasner, alcohol, ammonia, etc...) before starting the motorcycle.
- 2.** Avoid long periods of idling as this can cause discoloration.
- 3.** Intake leaks can cause the engine to run lean and overheat, this could lead to discoloration.
- 4.** Make sure there are no exhaust leaks at the junction of the exhaust pipes and cylinder head. We recommend replacing gaskets if they are worn.

EXHAUST CARE (BLACK)

- 1.** When installing a new set of black pipes, make sure your hands are clean and free of oil. After installation, thoroughly clean pipes with warm soapy water and a soft cloth. Dry with a clean towel to remove any residue before starting the motorcycle. Do NOT use anything abrasive to clean pipes.
- 2.** Avoid long periods of idling as this can cause discoloration.
- 3.** Intake leaks can cause the engine to run lean and overheat, this could lead to discoloration.
- 4.** Make sure there are no exhaust leaks at the junction of the exhaust pipes and cylinder head. We recommend replacing gaskets if they are worn.

Emissions Notice:

In California, in order to meet Air Resources Board emissions requirements, certain aftermarket part applications have been identified as replacements, and others have received ARB Executive Orders. All other emissions related aftermarket parts are for competition use only. A list of replacement parts and EO parts, and corresponding fitment is provided at vanceandhines.com/california.

Warranty:

All Vance & Hines products are warranted against defects in material and workmanship for a period of 90 days. This warranty does not cover discoloration or rust. This warranty shall be limited to the repair or replacement of the product, which may be proven defective under normal use. Vance & Hines will not warranty any system that has been abused, misused, improperly installed or modified.

Dealers or distributors are not authorized to make dispositions binding upon Vance & Hines. Vance & Hines will not be responsible for any labor charges incurred in removing or replacing any system under warranty. A return authorization number and a copy of the original purchase invoice must accompany all returns. Parts returned without a return authorization may be refused.

13861 ROSECRANS AVENUE / SANTA FE SPRINGS, CA 90670
SALES: (562) 921-5388
TECHNICAL: (562) 926-5291
FAX: (562) 802-0110

vanceandhines
.com