



# YOSHIMURA

RESEARCH & DEVELOPMENT OF AMERICA, INC.

5420 DANIELS STREET STE A, CHINO CA., 91710 · (800) 634-9166 · (909) 628-4722 · FAX (909) 591-2198

[www.yoshimura-rd.com](http://www.yoshimura-rd.com)

## Street Series

Qualified Manufacturer Declared "Replacement Part"

2008~2020

**Suzuki GSX1300R Hayabusa**

**1121202 (CF/CF)**

**1121205 (SS/CF)**

**1121207 (Ti/CF)**

**R-77 Stainless Steel Slip-On**

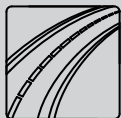

All Street Series systems are:

- Slip-on/Bolt-on applications that do not require tampering with the vehicle's emissions control system.
- CARB/EPA tail-pipe emissions compliant.
- Marked with appropriate EPA noise labels.
- Not tested for EPA new vehicle noise compliance.



*You must know how to remove and replace your stock exhaust in order to install this product otherwise have it installed by a professional mechanic. Keep all stock parts from your existing system as some components may be necessary to install your new Yoshimura exhaust depending on the application. Read through all instructions before beginning installation. Exhaust system can be extremely hot. Let motorcycle cool down before beginning installation. Always wear hand and eye protection and take precautionary measures to avoid injury.*



NOTE: IN THE STATE OF CALIFORNIA, IT IS ILLEGAL TO MODIFY THE EMISSION CONTROL SYSTEM, WHICH INCLUDES THE CARBURETORS OF ANY VEHICLE.

**Caution:** Exhaust system can be extremely hot. Let motorcycle cool down before beginning installation.

**Note:** Read through all instructions before beginning installation.

### **Tools Needed:**

Metric Socket Set  
Ratchet and Extension  
Metric Combination Wrench Set  
Metric Allen Wrench Set  
Torque Wrench

### **Installation Steps:**

1 Remove stock mufflers, stock tailpipes, and stock exhaust gaskets.

**NOTE:** Stock exhaust gaskets will not be used between the stock header and the Yoshimura tailpipes.

2 Install rubber heat insulators to the inside of the Yoshimura muffler clamps.

3 Left and right muffler clamps are not the same. Part numbers for the muffler clamps are stamped onto the clamps near the bolt holes. The left muffler clamp is part number 1121-MPCL or 1121-MPCLX. The right muffler clamp is part number 1121-MPCA or 1121-MPCAX. Slide left muffler clamp onto left Yoshimura muffler and right muffler clamp onto right Yoshimura muffler.

4 Slide exhaust collector clamps over the inlets of the Yoshimura tailpipes and install Yoshimura tailpipes and mufflers onto the stock headers.

5 Bolt mufflers to the stock muffler mount locations using the stock muffler mount hardware (see Fig. 1).

6 Torque muffler mount bolts to 2.3 kgf-m (16.5 lb-ft).

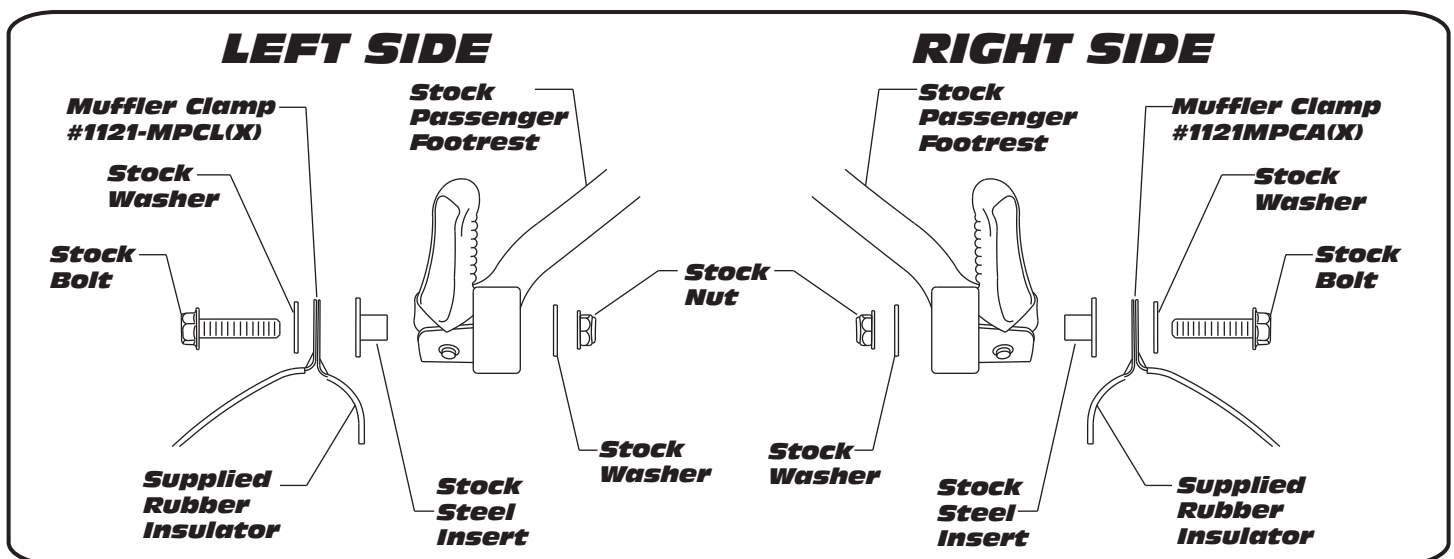

Fig. 1

- 7 Standing at the back of the motorcycle, check for proper alignment of the muffler. Adjust if necessary.

**NOTE:** To adjust fitment, it may be necessary to rotate the tailpipe or the muffler independently until proper alignment of the muffler is achieved. You will be installing a securing rivet into each tailpipe to prevent the tailpipe from rotating while the motorcycle is in operation.

- 8 Drill a 13/64" hole thru the securing hole of each tailpipe and into the stock header using the securing hole as a guide.

**CAUTION:** Always wear eye protection when using any power tools.

- 9 Insert one securing rivet into each drilled hole, slide supplied stainless steel collector clamp over rivet and torque clamp to 1.25 kg-m (9 lb-ft).
- 10 It is recommended that the muffler and tailpipe be wiped down with rubbing alcohol to remove oil and fingerprints. This will help prevent tarnishing of the finish after the exhaust is heated up.
- 11 Check for proper clearance between new exhaust system and motorcycle. (i.e. Swing-arm, body work, etc.) If any problem is found, please carefully follow through the installation steps again. If problem still persists, please call Yoshimura technical department at (800)634-9166 / in CA (909)628-4722.

**Note:** After starting motorcycle, it is normal for new exhaust system and muffler to smoke until oil residue burns off.

**#112120(2,5,6,7)**

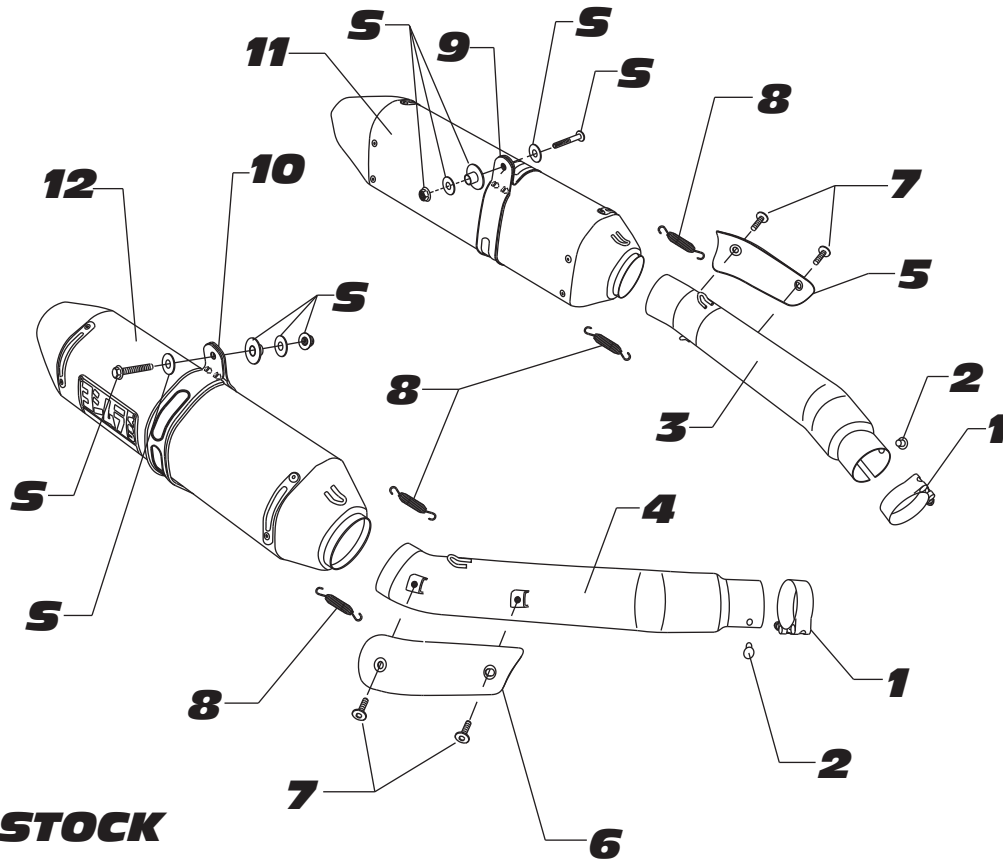

**S = STOCK**

Parts Diagram

NO.	DESCRIPTION	QTY	PART #
1	Exhaust Collector Clamp	2	03019127
2	Collector Rivet	2	S-RIVET
3	Yoshimura Tailpipe (Left)	1	1121-426
4	Yoshimura Tailpipe (Right)	1	1121-427
5	Yoshimura Tailpipe Heatshield (Left)	1	1121-HSL
6	Yoshimura Tailpipe Heatshield (Right)	1	1121-HSR
7	Heatshield Mounting Bolts	4	RC116HSB
8	82mm Race Spring	4	RACE-82MM
9	Stainless Steel Muffler Clamp (Left) with Carbon Fiber Sleeve with Stainless Steel or Titanium Sleeve	1	1121-MPCL 1121-MPCLX
10	Stainless Steel Muffler Clamp (Right) with Carbon Fiber Sleeve with Stainless Steel or Titanium Sleeve	1	1121-MPCA 1121-MPCAX
11	Yoshimura Muffler (Left) with Carbon Fiber Sleeve and Carbon Fiber Endcap with Stainless Steel Sleeve and Carbon Fiber Endcap with Stainless Steel Sleeve and Stainless Steel Endcap with Titanium Sleeve and Carbon Fiber Endcap	1	CRR77146WL SRR77146WL SRR77146WL-SS TRR77146WL
12	Yoshimura Muffler (Right) with Carbon Fiber Sleeve and Carbon Fiber Endcap with Stainless Steel Sleeve and Carbon Fiber Endcap with Stainless Steel Sleeve and Stainless Steel Endcap with Titanium Sleeve and Carbon Fiber Endcap	1	CRR77146W SRR77146W SRR77146W-SS TRR77146W
**	Muffler Clamp Heat Insulator	2	HT SHLDR77
**	Spring Puller Tool	1	ST-200
**	Yoshimura Vinyl Sticker	1	17100