



# YOSHIMURA

RESEARCH&DEVELOPMENT OF AMERICA, INC.

5420 DANIELS STREET STE A, CHINO CALIF. 91786 · (800)634-9166 · (909)628-4722 · FACSIMILE (909)591-2198

[www.yoshimura-rd.com](http://www.yoshimura-rd.com)

## Adjustable Rearset Bracket Kit

**Yamaha**  
**YZF-R3**

**500HA133200**

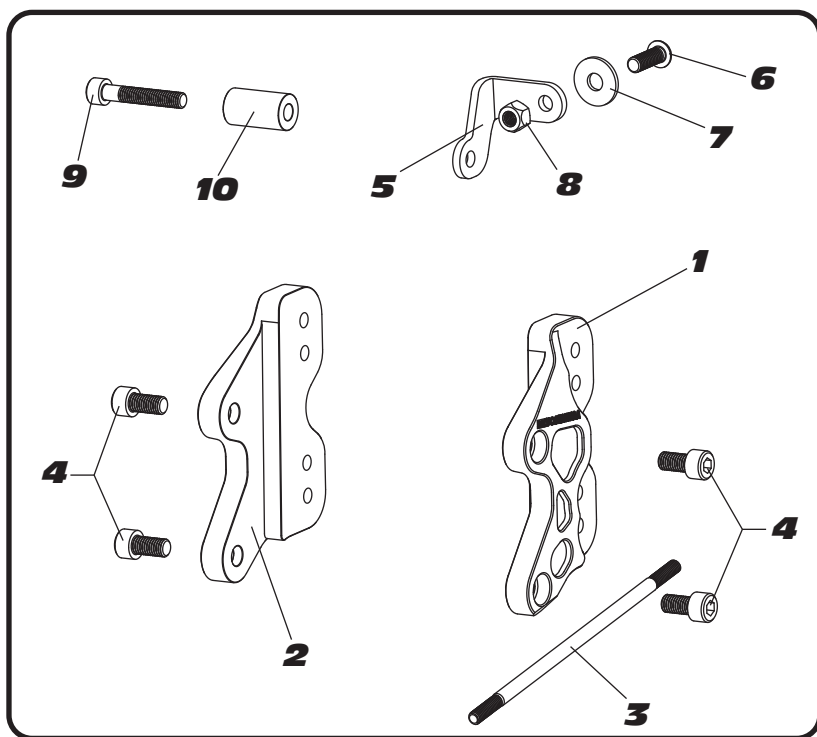

### **IMPORTANT**

The installation of this product requires the rear brake line to be replaced with a shorter brake line.

It is recommended to order Goodridge's brake line when installing the Yoshimura rearset offset bracket kit for the perfect OEM fit and finish.

#### **Goodridge Part No.**

**YOSH-YZFRR**

Rear Kit w/ Stainless Steel Hardware

**YOSH-YZFRRCH**

Rear Kit w/ Chrome Plated Mild Steel Hardware

#### **Parts List:**

	<b>DESCRIPTION</b>	<b>QTY</b>	<b>PART #</b>
1	Left Rearset Bracket	1	500HA133200L
2	Right Rearset Bracket	1	500HA133200R
3	Shift Link Rod	1	R-K8SR173SS
4	8mm x 16mm Socket Head Bolt	4	M8X16
5	Rear Brake Reservoir Bracket	1	13320-RSV-BKT
6	6mm x 18mm Button Head Screw	1	M6X18BHS
7	6mm Flat Washer	1	6MMWASHERL
8	6mm Lock Nut	1	6MMLN
9	6mm x 35mm Socket Head Bolt	1	M6X35
10	Aluminum Spacer	1	6X14X25SPCRHA
**	Thread Lock Adhesive	1	R-K880ND
**	Yoshimura Sticker Sheet	1	17029

#### **Adjustable Positions:**

Upper Position	Back	45mm
	Up	35mm
Lower Position	Back	45mm
	Up	20mm

## Installation

1. Remove the stock shift rod by loosening the shift rod locknuts. Remove the two bolts securing left footpeg assembly to frame.
2. Apply provided thread lock to (No. 4) *M8X16*, bolt and secure (No. 1) *500HA133200L*, left rearset bracket to frame. Torque to factory specification.
3. Apply thread lock onto the stock bolts and secure the stock left footpeg assembly onto (No. 1) *500HA133200L*, left rearset bracket. Torque to factory specification.

Note: The stock rearset can be installed in two positions. See chart on front page for technical specifications.

4. Remove the locknuts from the stock shift rod and install onto (No. 3) *R-K8SR173SS*, shift rod. Install (No. 3) *R-K8SR173SS*, shift rod onto shift lever and shift arm. Torque locknuts to factory specification.

Note: Be sure to check position and clearance of shift lever action before operating vehicle.

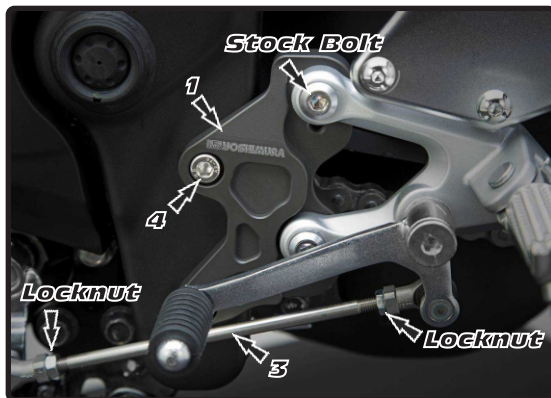

5. Carefully drain brake fluid and remove the stock rear brake hose guide bolt secured onto swingarm. Remove the stock brake line from rear caliper and master cylinder.

Note: Clean up brake fluid immediately as it may damage painted surfaces and plastic parts.

6. Remove bolt securing the rear brake reservoir onto frame.
7. Remove right rearset by removing the two stock bolts securing right footpeg assembly to frame.

8. Apply provided thread lock to (No. 4) *M8X16*, bolt and secure (No. 2) *500HA133200R*, right rearset bracket to frame. Torque to factory specification.
9. Apply thread lock onto the stock bolts and secure the stock left footpeg assembly onto (No. 2) *500HA133200R*, right rearset bracket. Torque to factory specification.

Note: The stock rearset can be installed in two positions. See chart on front page for technical specifications.



10. Install (No. 5) *13320-RSV-BKT*, reservoir bracket using the stock bolt. Secure rear brake reservoir to (No. 5) *13320-RSV-BKT*, reservoir bracket using (No. 6) *M6X18BHS*, bolt (No. 7) *6MMWASHERL*, washer and (No. 8) *6MMLN*, lock nut. See diagram for proper orientation and order of hardware.



11. Install shorter brake line onto rear caliper and master cylinder.

Note: If Goodridge brake line is used, secure brake line to swingarm using P-Clamp (incl. in Goodridge kit) and (No. 9,10) bolt and aluminum spacer.

12. Follow factory service manual for proper brake bleeding procedure. Test and inspect brake system prior to riding.