



YOSHIMURA

RESEARCH & DEVELOPMENT OF AMERICA, INC.

5420 DANIELS STREET STE A, CHINO CALIF. 91710 · (800) 634-9166 · (909) 628-4722 · FAX (909) 591-2198

www.yoshimura-rd.com

Turn Signal Diode Kit KK000106

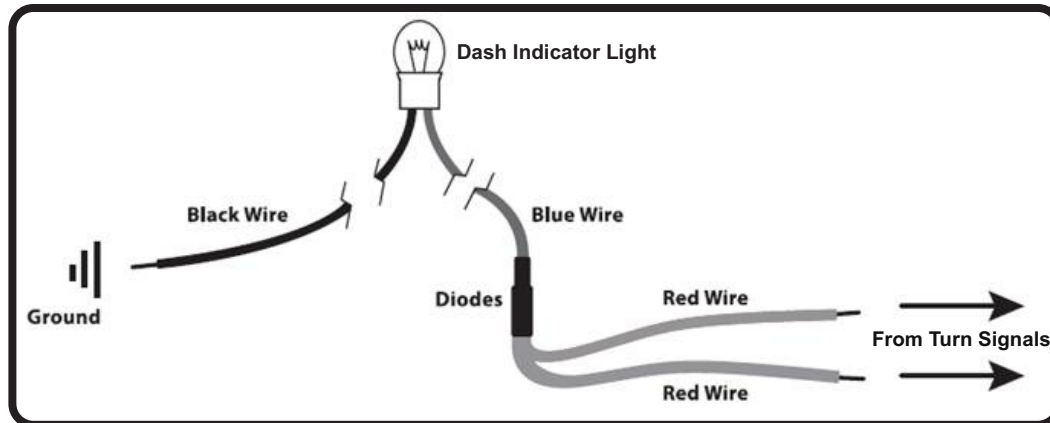

This product is designed to remedy turn signal issues where the turn signal light stays illuminated and does not flash as a result of switching to LED's. If you have a single bulb turn signal indicator, this assembly is required for proper turn signal operation.

It is recommended to solder wire connections and use shrink tube to seal connection. Solder shrink tube connectors are available through Yoshimura and are sold separately.

WARNING

Disconnect battery before beginning installation to avoid potential electrical shock.

Installation Instructions

1. Using the wiring diagram from your service manual, locate the turn signal dash indicator light wires.
2. Cut turn signal dash indicator light wires at least 4" from the dash indicator light.
3. Splice and connect the separate black wire to one of the dash indicator light wires leading to the dash light. Attach black wire to nearest unpainted chassis point.
4. Splice and connect the blue diode wire to the other dash indicator light wire leading to the dash light.

Note¹: The light does not have polarity and is not critical which wire is connected to the dash indicator light wire.

Note²: The diode is directional which is critical to proper operation. Do not connect the two red wires to the dash indicator light wires leading to the dash light.

5. Splice and connect the two red wires on diode to the wiring harness leading to the turn signals.
6. Reconnect the battery.
7. Check for proper function of turn signals and that all connections are secure prior to riding.